

# Micro2451 1506

FriendlyARM

|       |                        |               |
|-------|------------------------|---------------|
| Title |                        |               |
|       |                        |               |
| Size  | Document Number        | Rev           |
| A3    | <Doc>                  |               |
| Date: | Tuesday, July 14, 2015 | Sheet 1 of 11 |

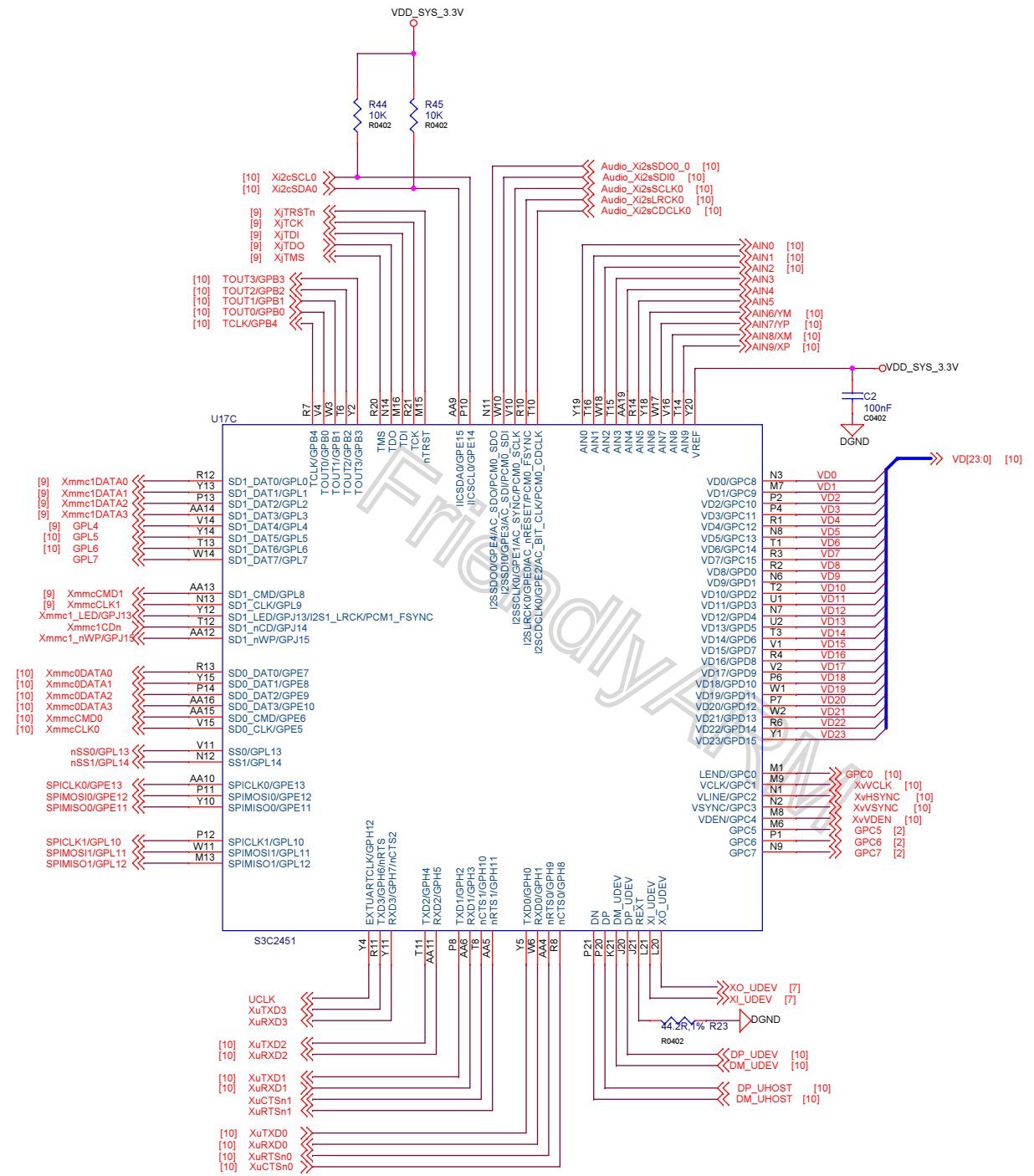



|       |                          |               |
|-------|--------------------------|---------------|
| Title |                          |               |
| Size  | Document Number          | Rev           |
| A3    |                          |               |
| Date: | Wednesday, July 15, 2015 | Sheet 3 of 11 |

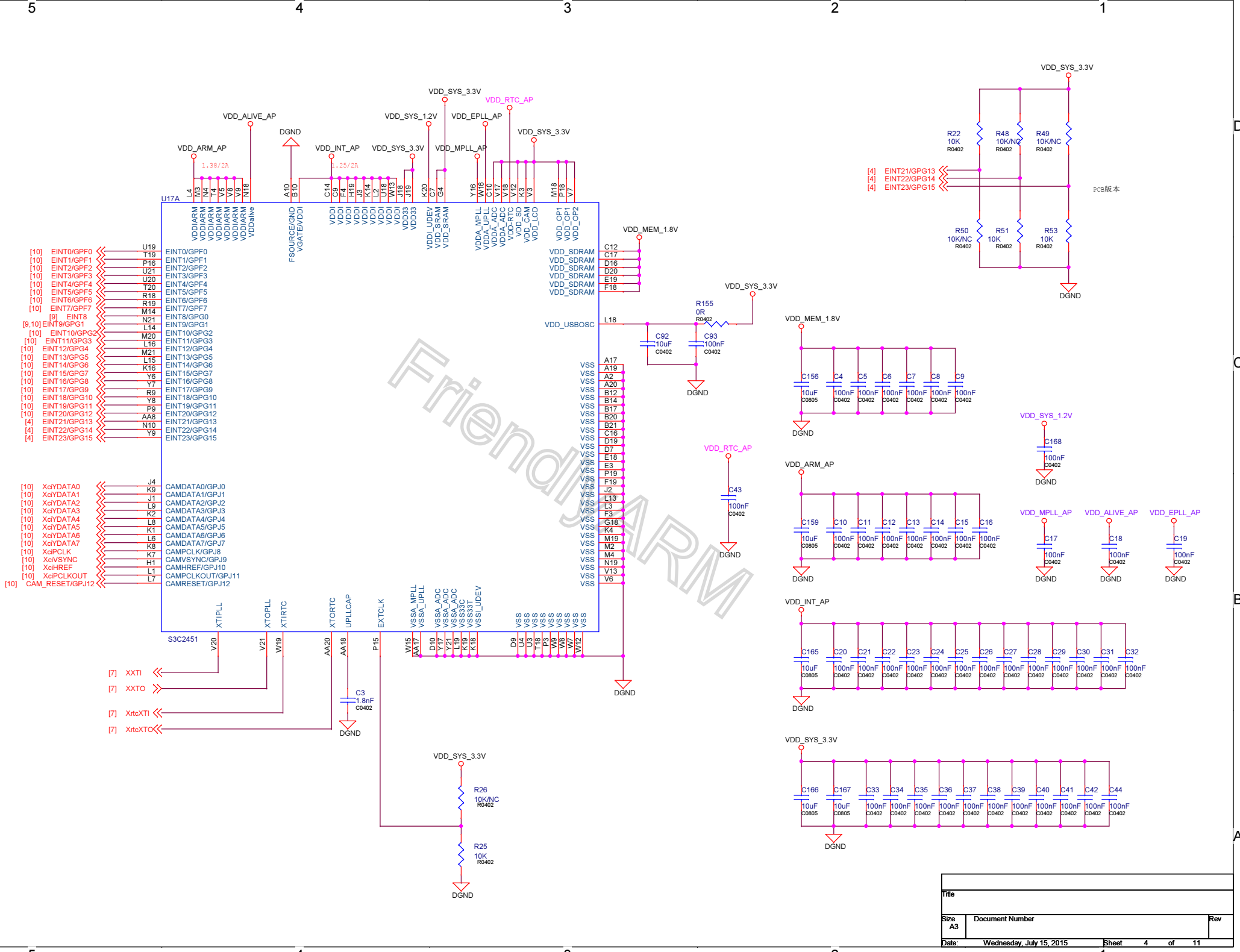

| Title |                          |               |
|-------|--------------------------|---------------|
| Size  | Document Number          | Rev           |
| A3    |                          |               |
| Date: | Wednesday, July 15, 2015 | Sheet 4 of 11 |

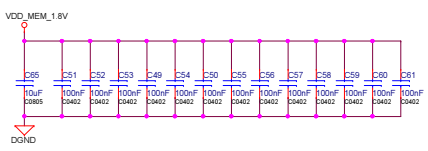
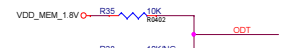
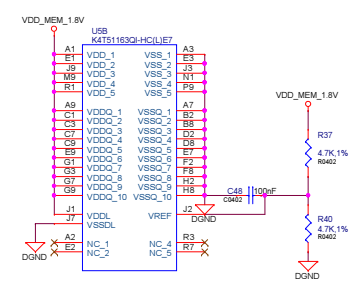
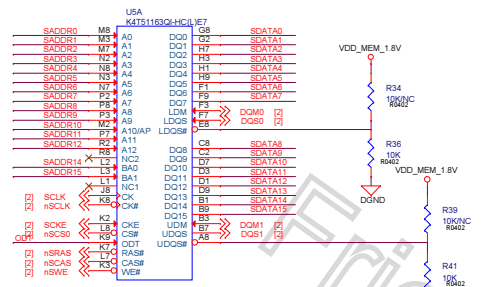
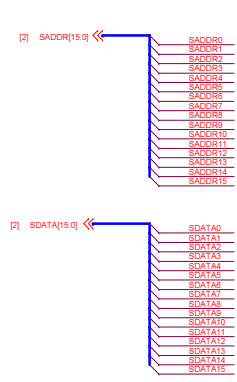

friendlyARM

|       |                        |               |
|-------|------------------------|---------------|
| Title |                        |               |
| Size  | Document Number        | Rev           |
| A2    |                        |               |
| Date: | Tuesday, July 14, 2015 | Sheet 5 of 11 |

### NAND Flash memory

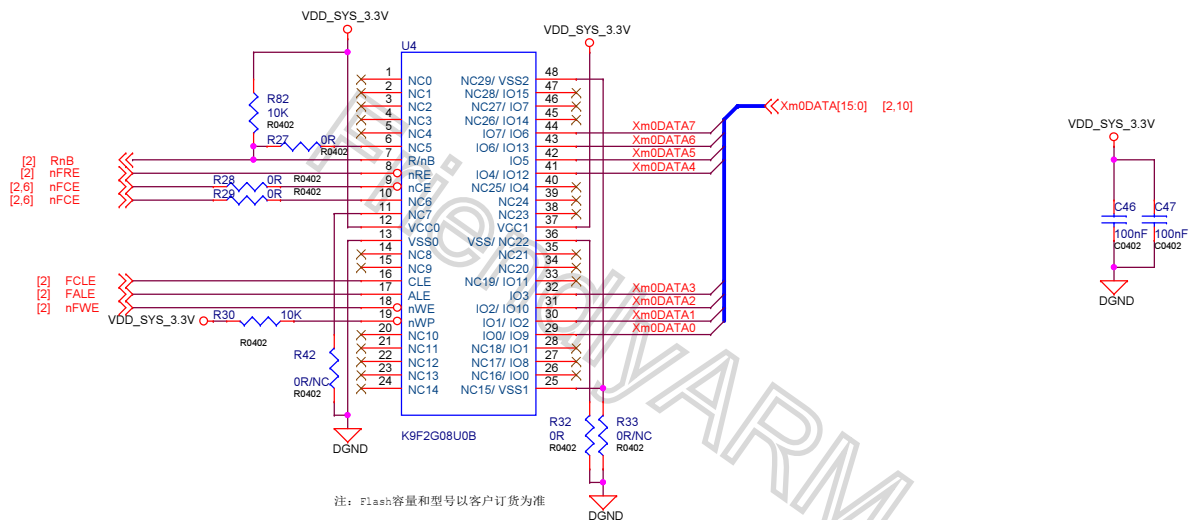

注: Flash容量和型号以客户订货为准

|       |                        |               |
|-------|------------------------|---------------|
| Title |                        |               |
| Size  | Document Number        | Rev           |
| A3    | <Doc>                  | <Rev>         |
| Date: | Tuesday, July 14, 2015 | Sheet 6 of 11 |

# Reset

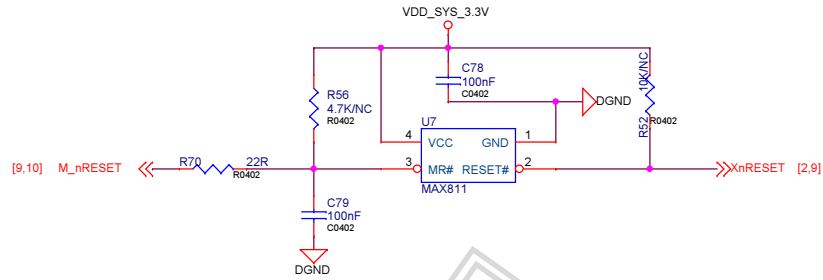

# Clock

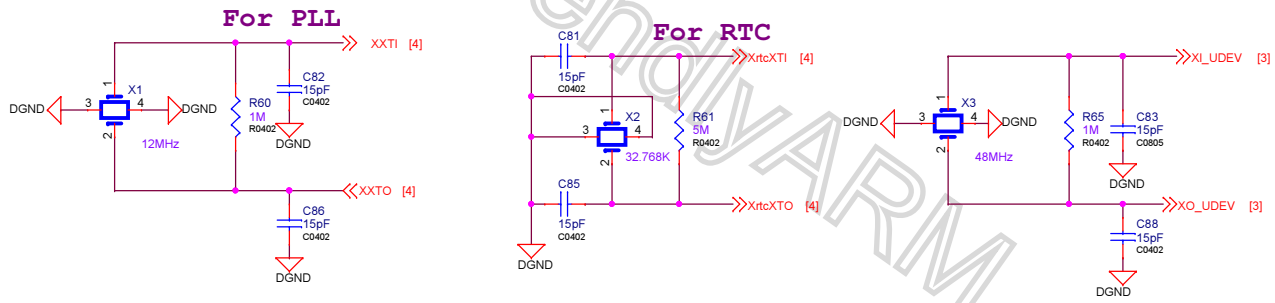

|                              |                 |     |
|------------------------------|-----------------|-----|
| Title                        |                 |     |
| Size A3                      | Document Number | Rev |
| Date: Tuesday, July 14, 2015 | Sheet 7 of 11   |     |

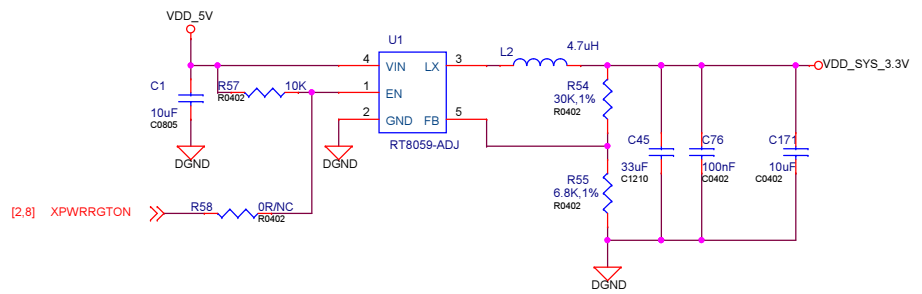
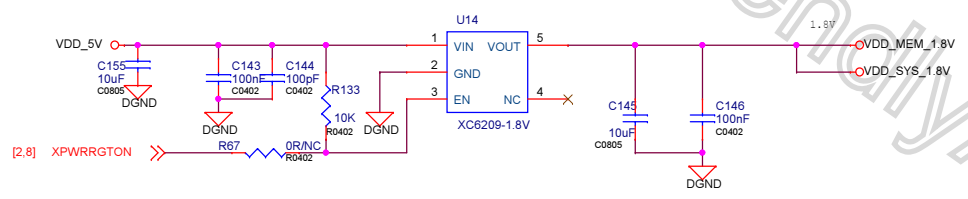
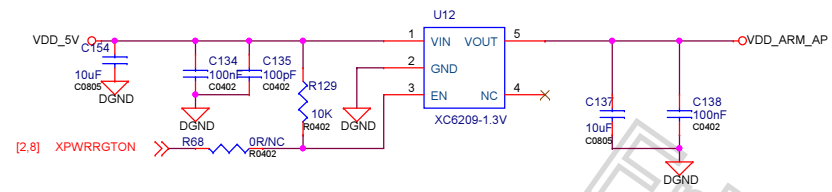
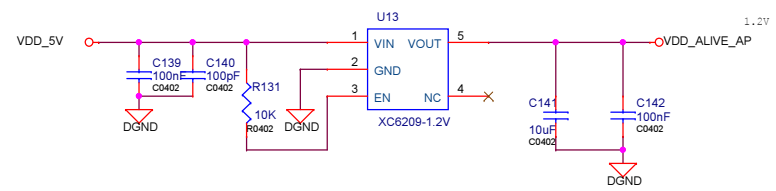
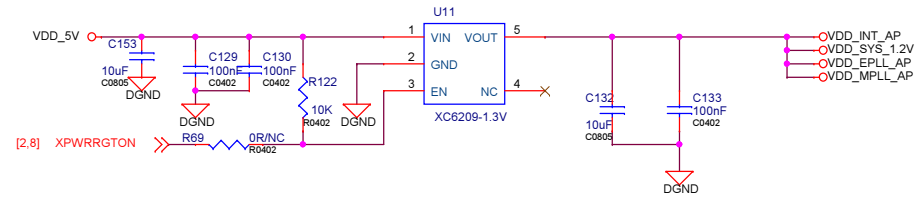

|                              |                 |     |
|------------------------------|-----------------|-----|
| Title                        |                 |     |
| Size A3                      | Document Number | Rev |
| Date: Tuesday, July 14, 2015 | Sheet 8 of 11   |     |



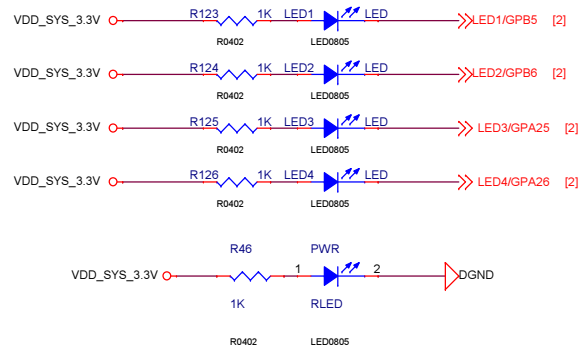
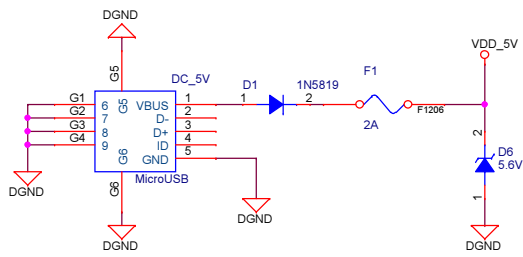
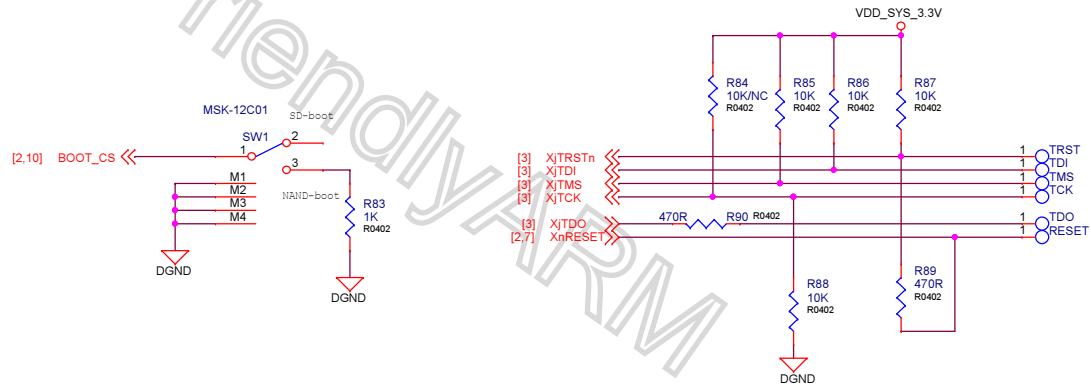
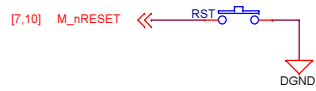
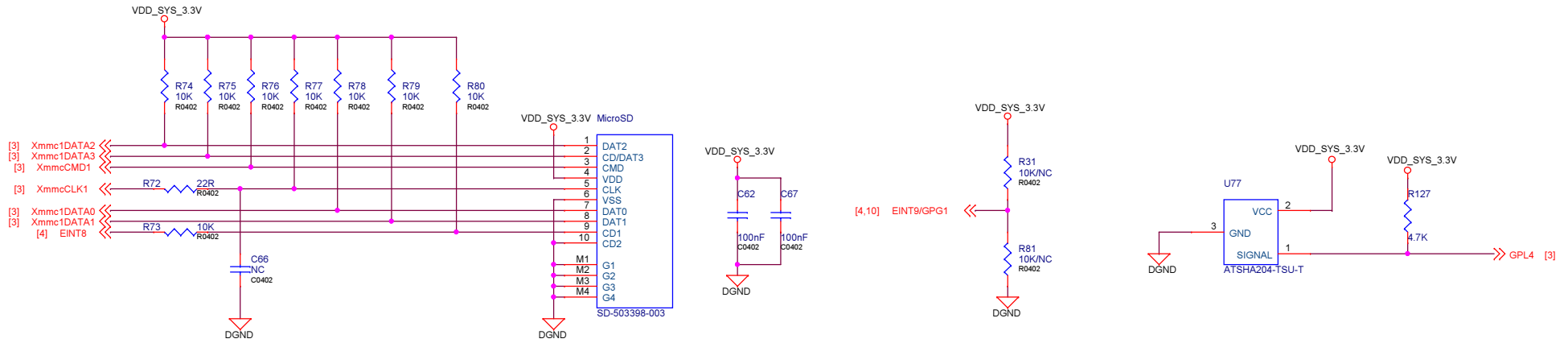

|            |                          |               |
|------------|--------------------------|---------------|
| Title      |                          |               |
| Size<br>A3 | Document Number<br><Doc> | Rev<br><Rev>  |
| Date:      | Wednesday, July 15, 2015 | Sheet 9 of 11 |

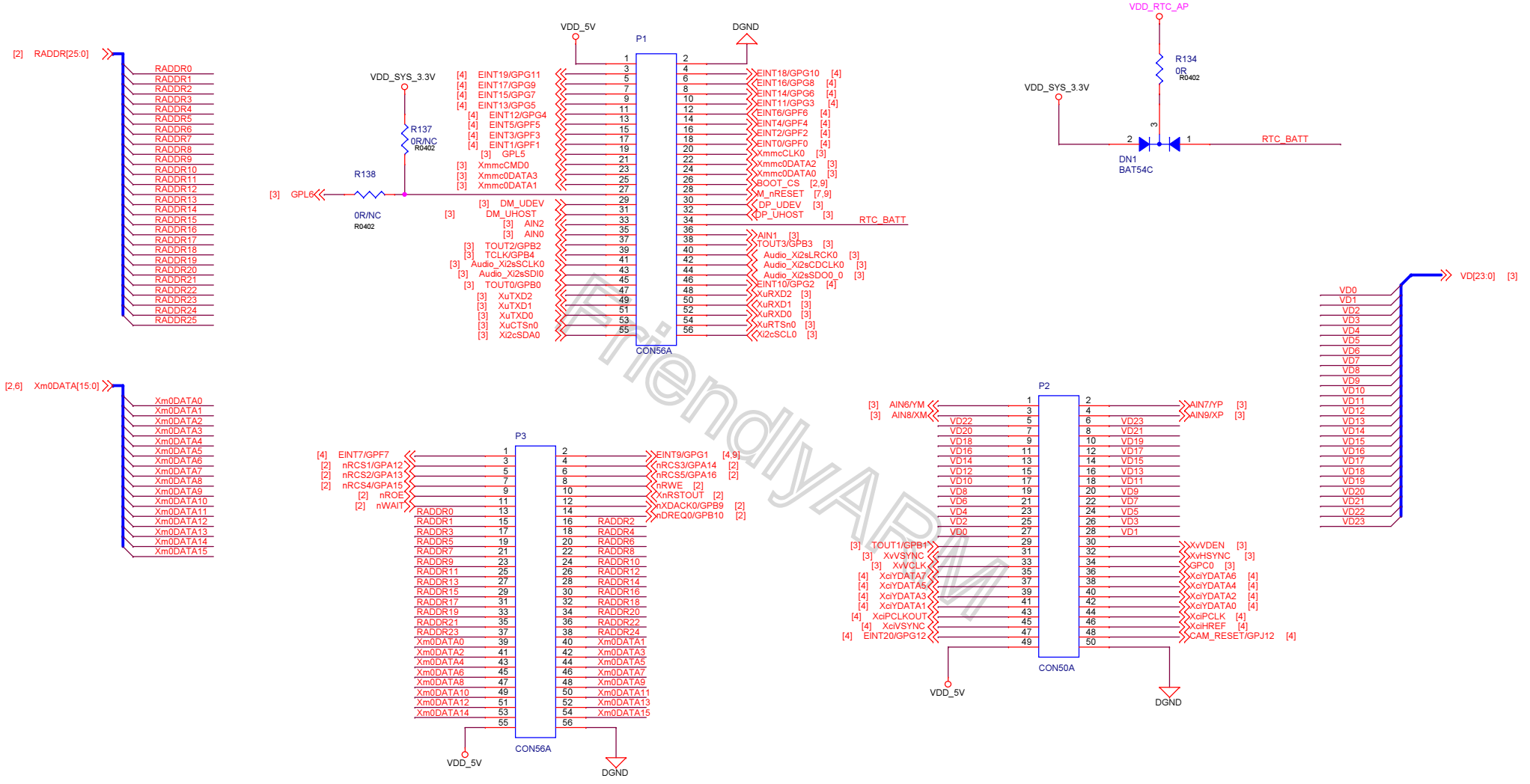

|                                |                 |     |
|--------------------------------|-----------------|-----|
| Title                          |                 |     |
| Size A3                        | Document Number | Rev |
| Date: Wednesday, July 15, 2015 | Sheet 10 of 11  |     |

D

D

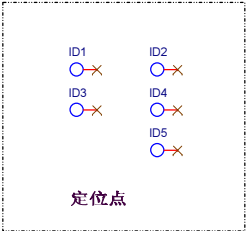

FriendlyARM

C

C

B

B

A

A

|       |                          |                |
|-------|--------------------------|----------------|
| Title |                          |                |
| 2451  |                          |                |
| Size  | Document Number          | Rev            |
| A3    |                          |                |
| Date: | Thursday, April 16, 2015 | Sheet 11 of 11 |
|       |                          | 1              |