

Core4418

Revision

1711 , First Release

FRIENDLYARM

Core4418		
Size	Document Number	Rev
A3	01.Title	<RevCode>
Date:	Wednesday, December 20, 2017	Sheet 1 of 15

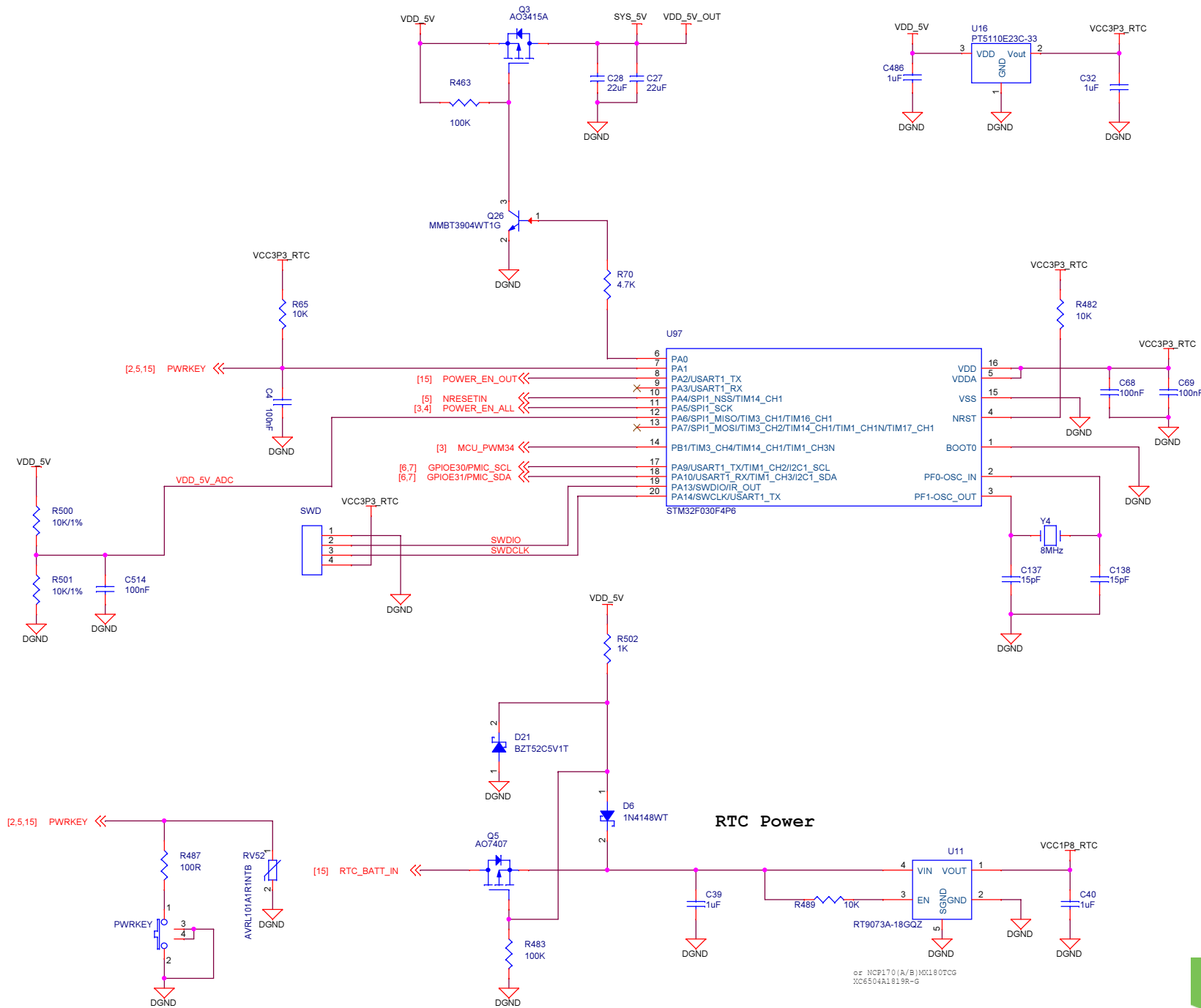

RTC Power



VDD_ARM

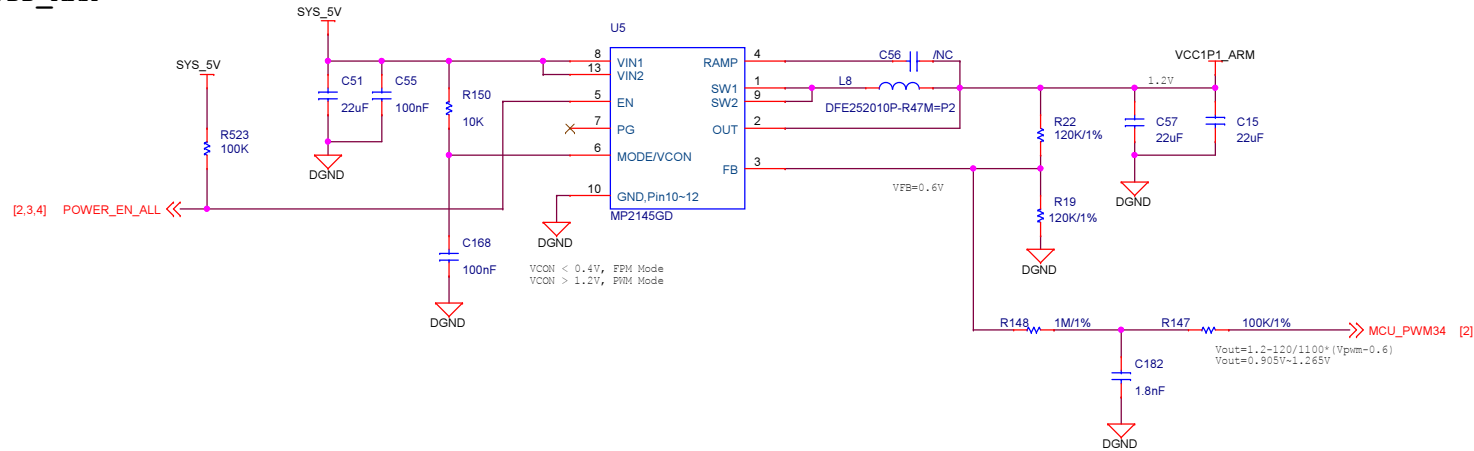

VDD_CORE

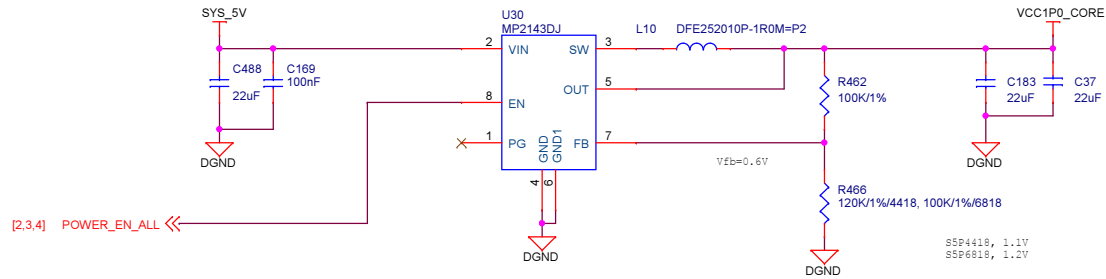

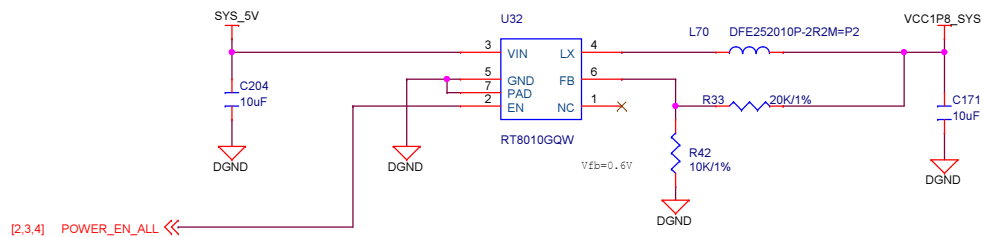
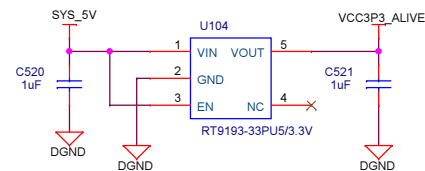
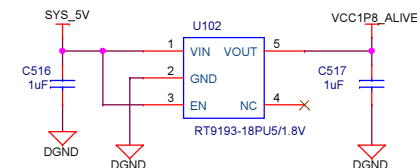
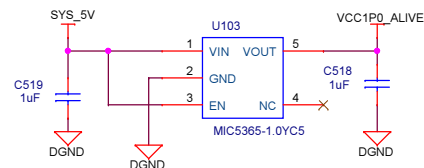
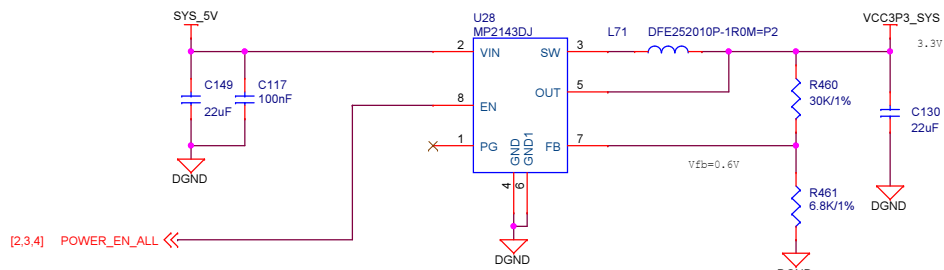
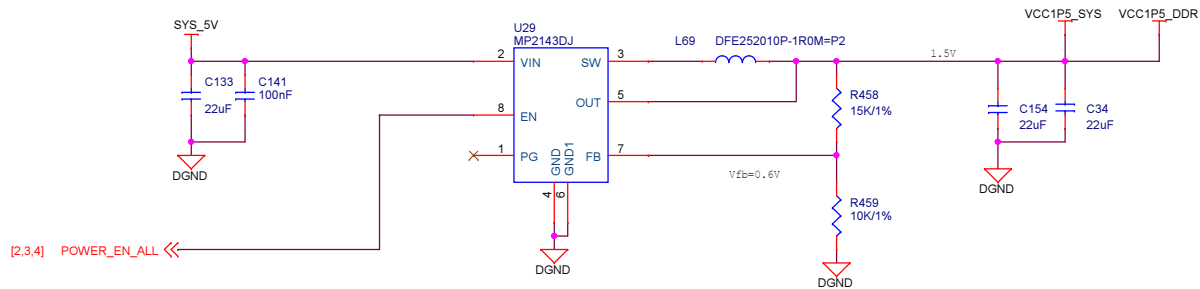

Title		
Core4418		
Size	Document Number	Rev
A3	<Doc>	<Rev Code>
Date:	Wednesday, December 20, 2017	Sheet 4 of 15

System Reset, Clocks

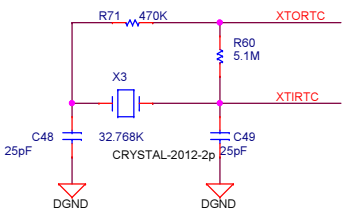
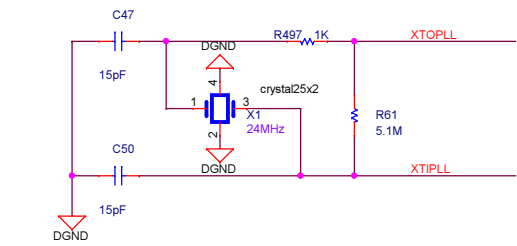
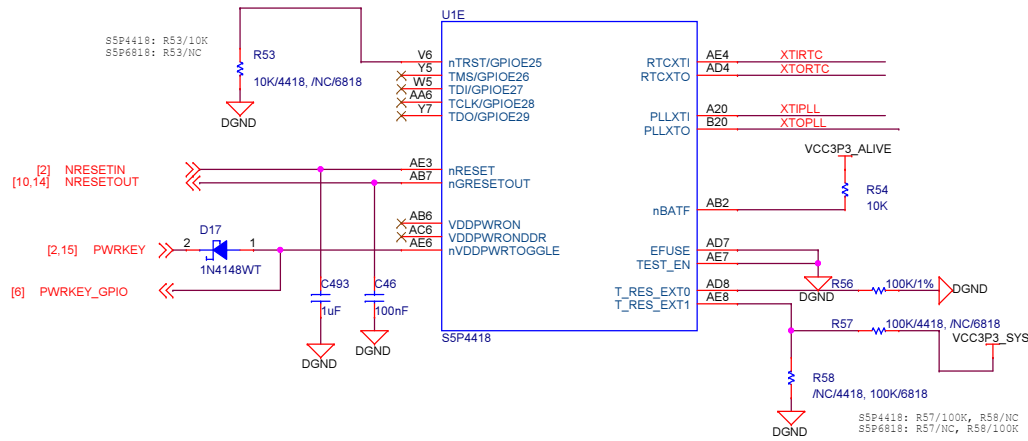

Boot Mode Config

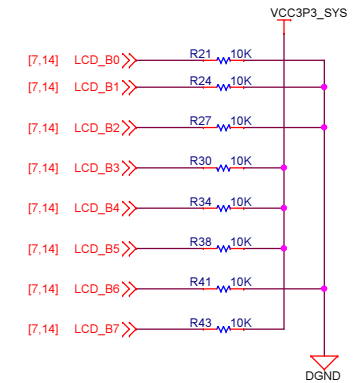
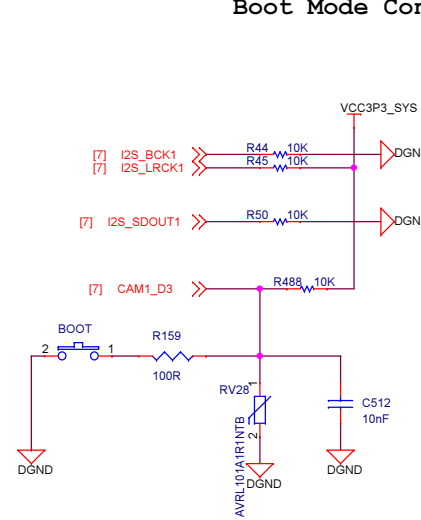

BOOT MODE OPTION

	eMMC	SPI	USB	NAND
SD0	HIGH	LOW	LOW	HIGH
SD1	LOW	LOW	HIGH	HIGH
SD2	HIGH	HIGH	HIGH	HIGH
SD4	LOW	HIGH		
SD5	LOW	LOW		

Boot media port select (SPI, eMMC)

	CH0	CH1	CH2
SD3	LOW	HIGH	LOW
CAM1_D3	LOW	LOW	HIGH



AP Peripherals

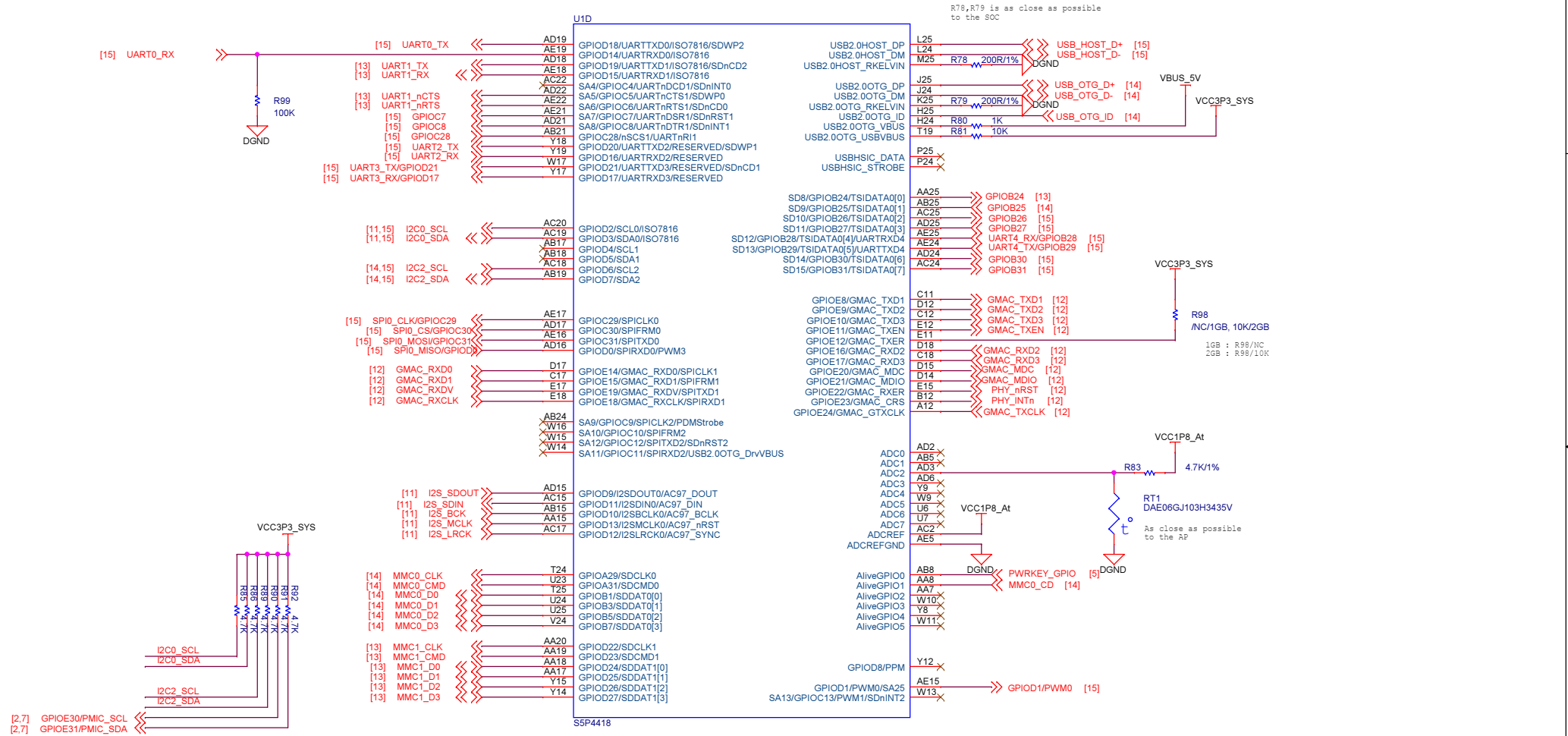

I2C CH0 : Camera
 I2C CH1 : HDMI EDID
 I2C CH2 : Touch
 PMIC_I2C : PMIC



Core4418		
Size A3	Document Number 04.AP Peripherals	Rev <RevCode>
Date	Wednesday, December 20, 2017	Sheet 6 of 15

AP VIP&Display

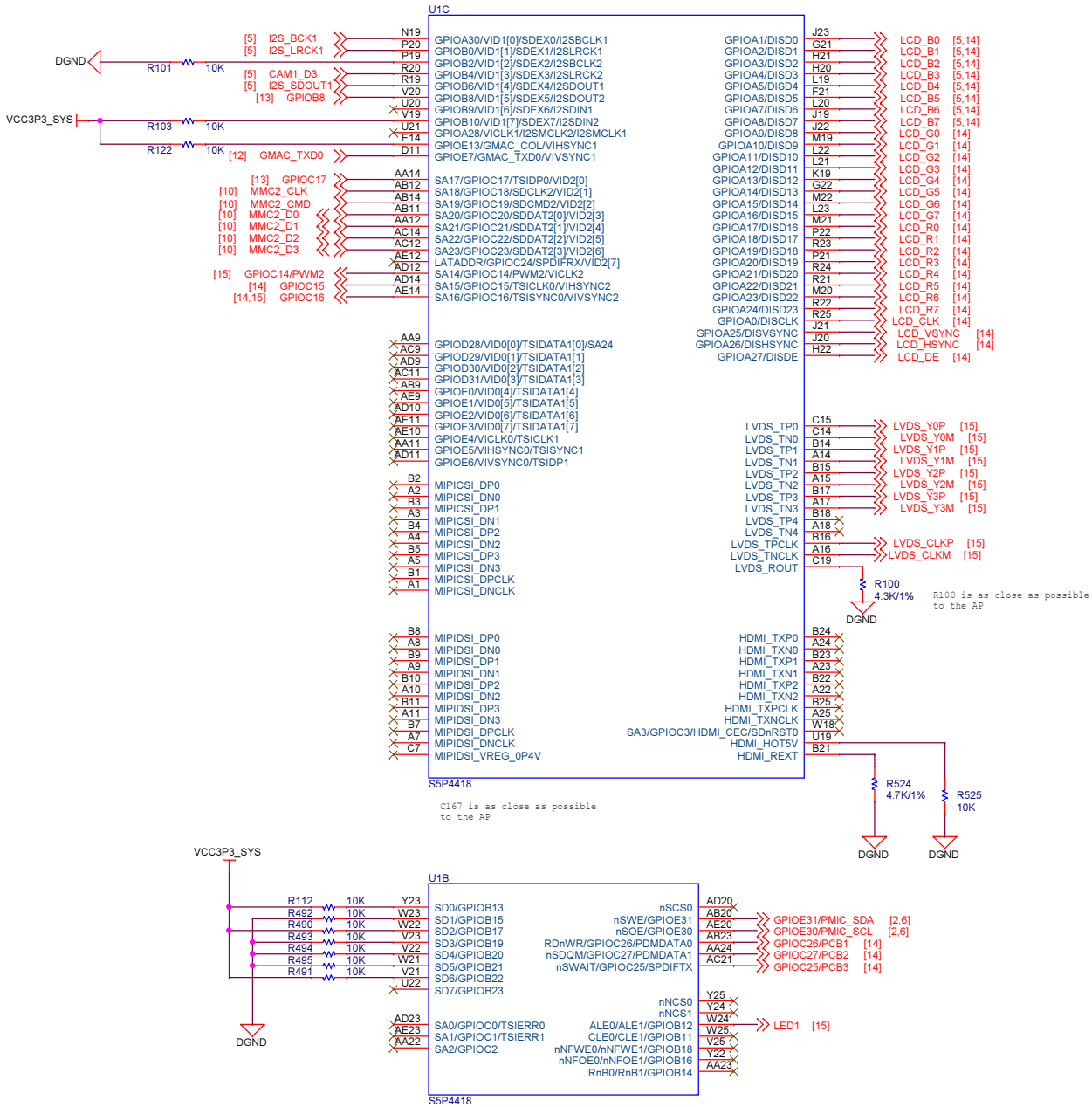

Reserved Function

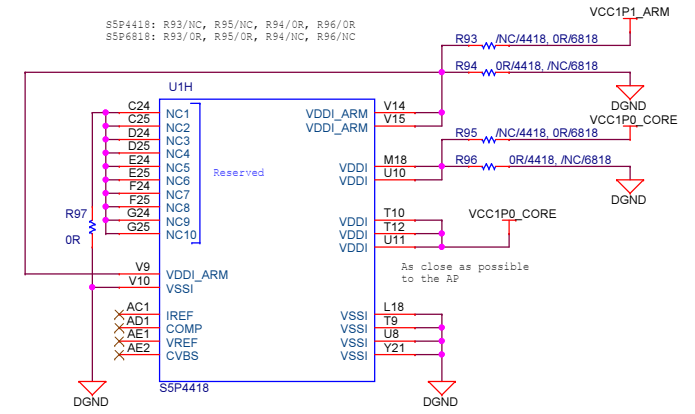

Core4418		
Size A3	Document Number 05.AP.VIP&Display	Rev <RevCode>
Date: Wednesday, December 20, 2017	Sheet 7	of 15

AP Power

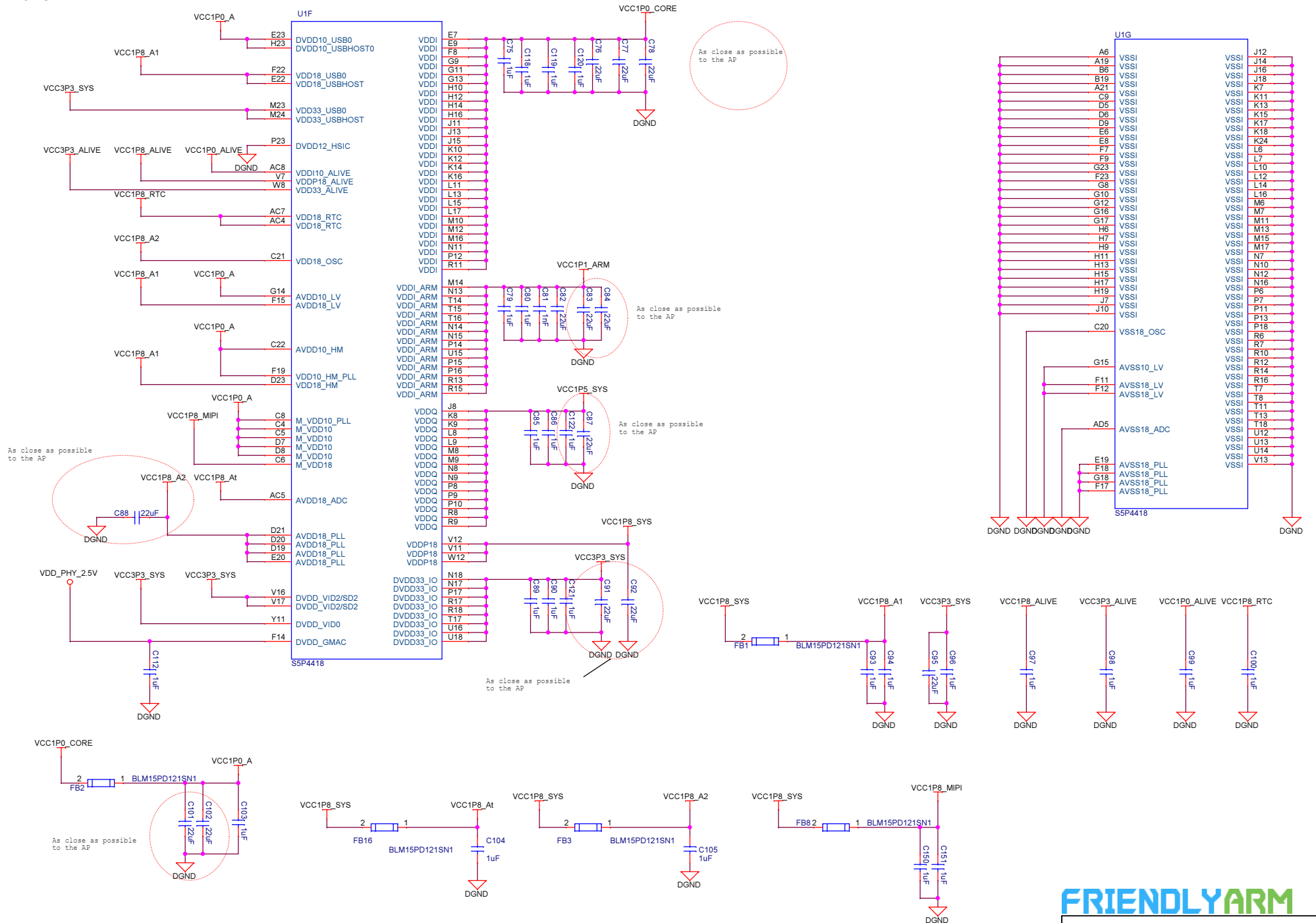

Core4418		
Size	Document Number	Rev
A3	06.AP Power	<RevCode>
Date:	Wednesday, December 20, 2017	Sheet 8 of 15

DDR3

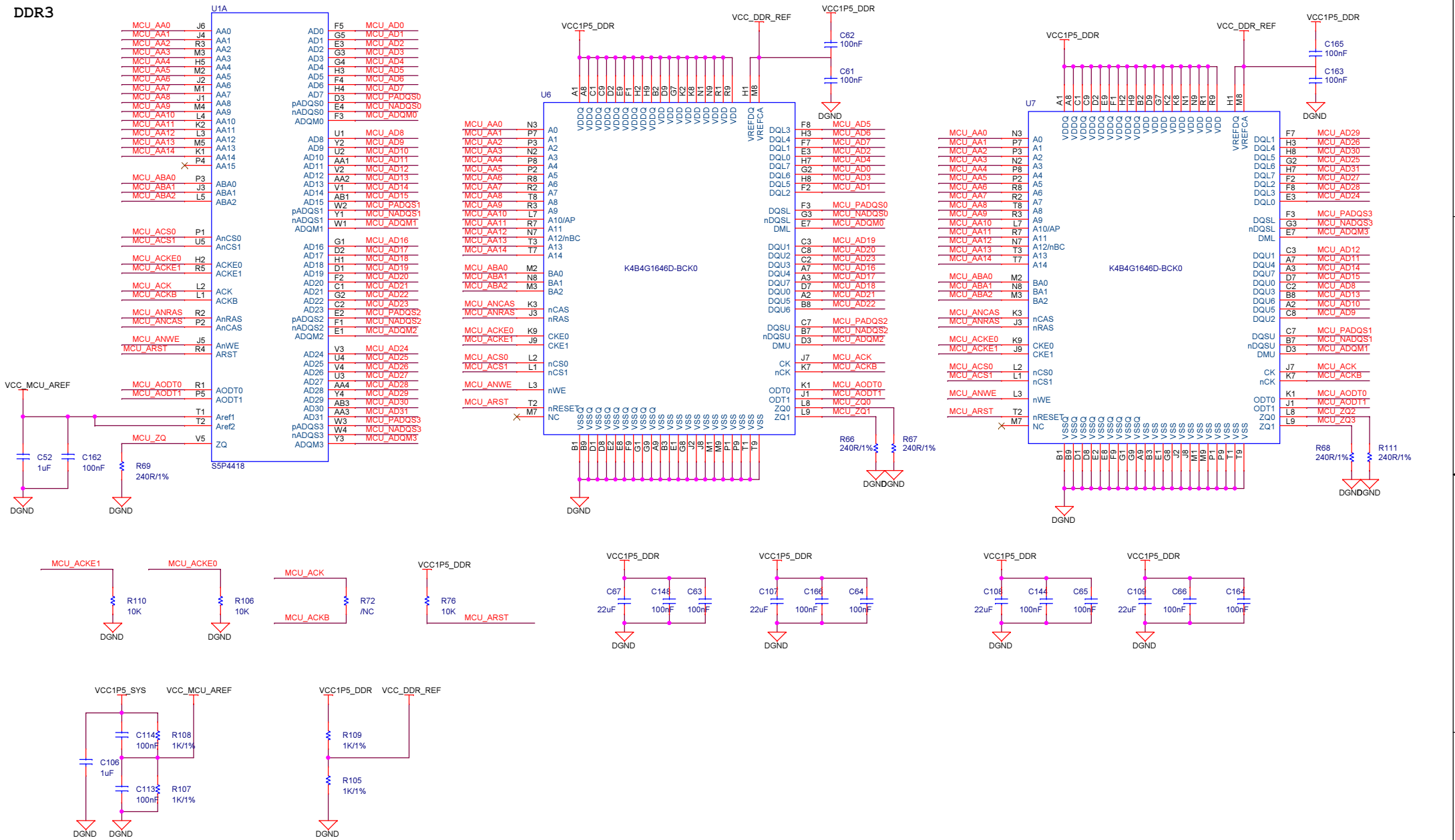

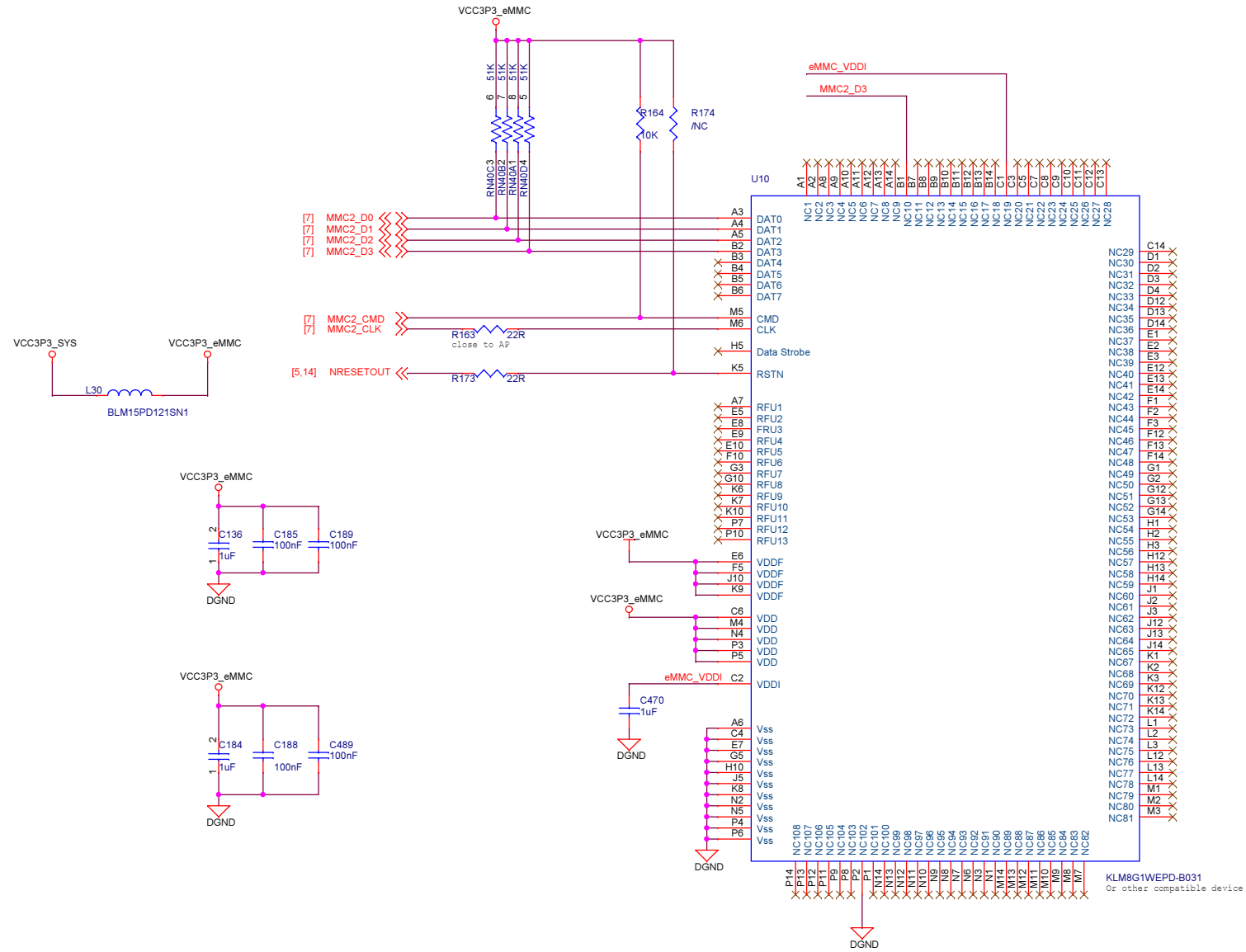

Audio

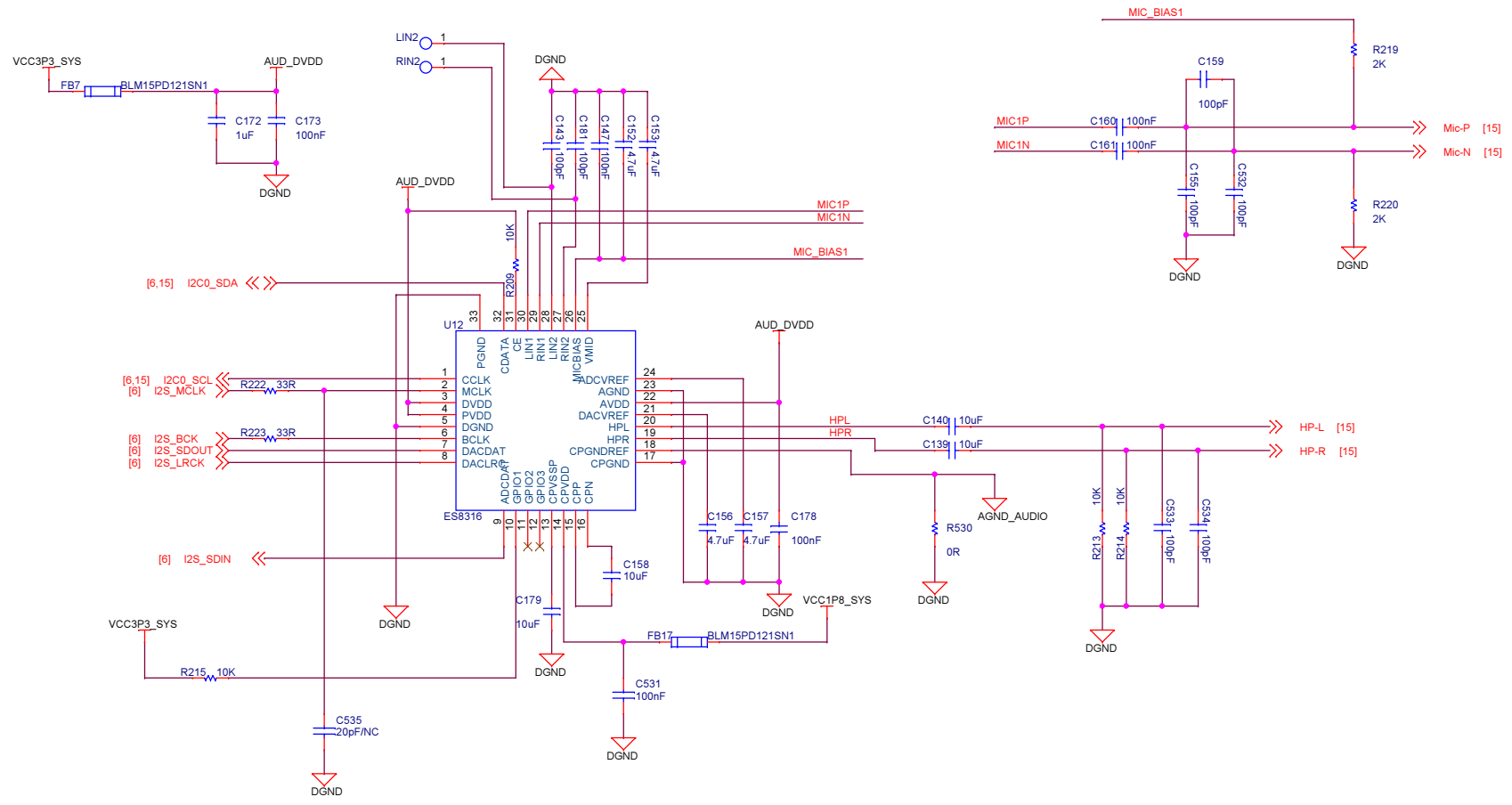

10/100/100M Ethernet

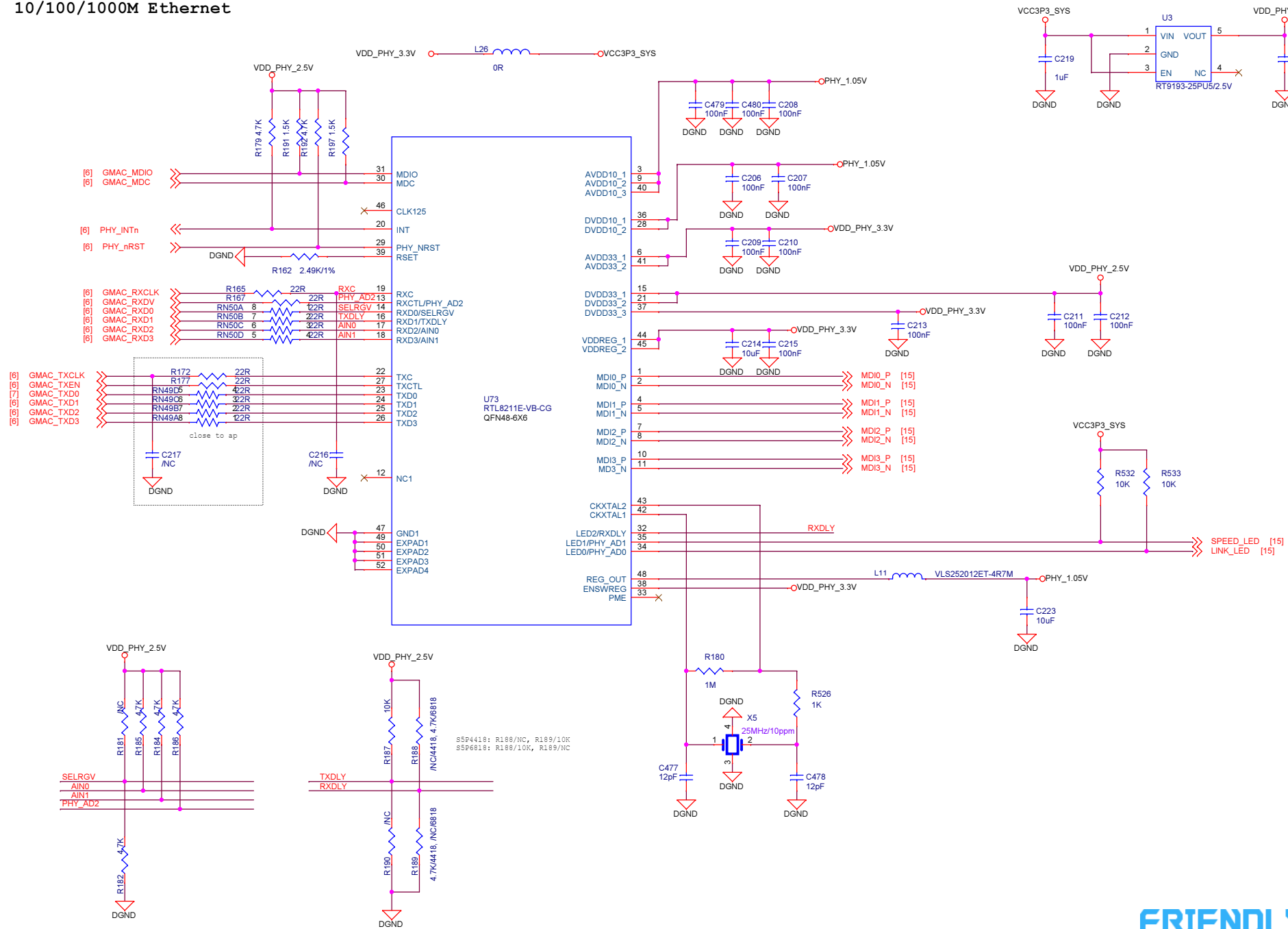

Core4418		
Size	Document Number	Rev
A3	14.LAN	<RevCode>
Date:	Wednesday, December 20, 2017	Sheet 12 of 15

Wi-Fi/Bluetooth

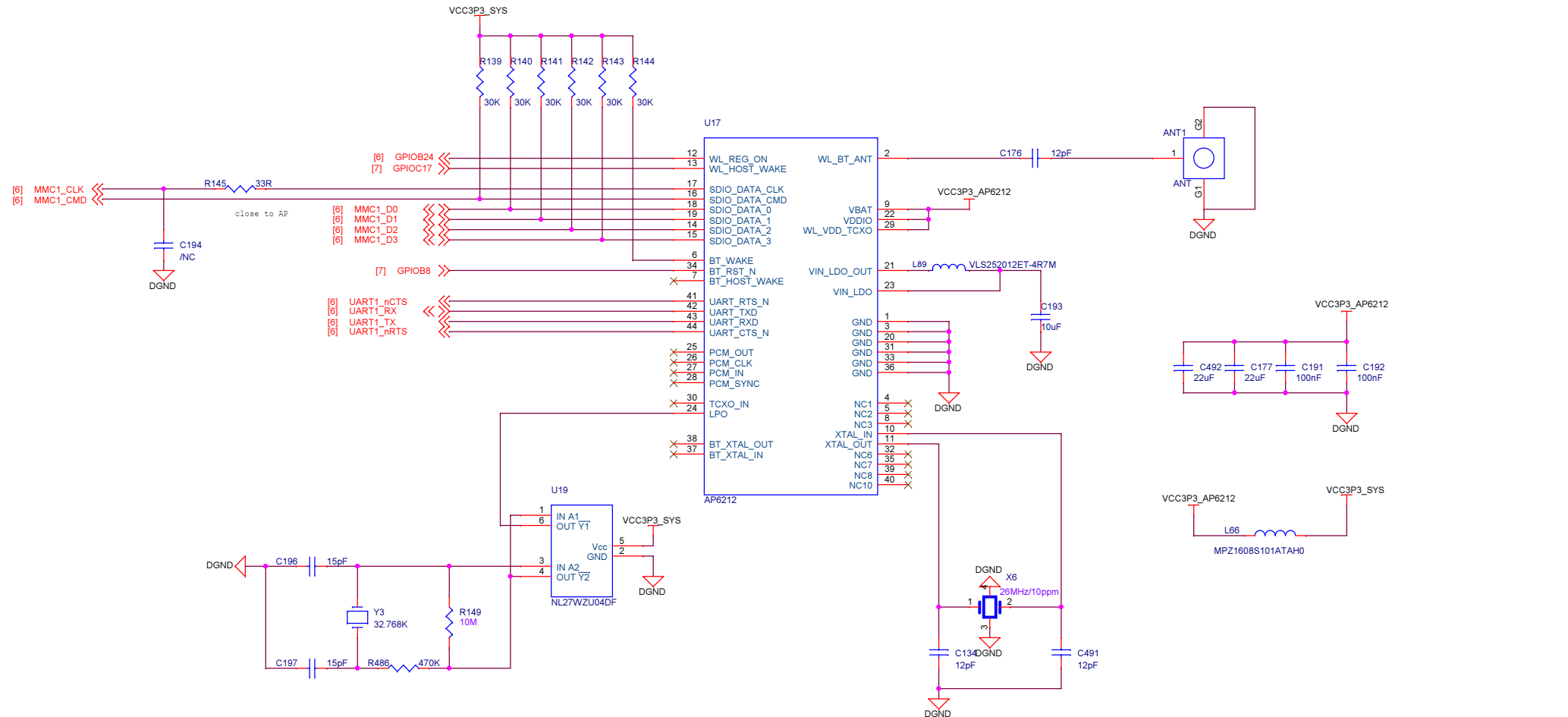

Title		Core4418
Size	Document Number	Rev
A3	<Doc>	<Rev Code>
Date:	Wednesday, December 20, 2017	Sheet 13 of 15

SDCARD

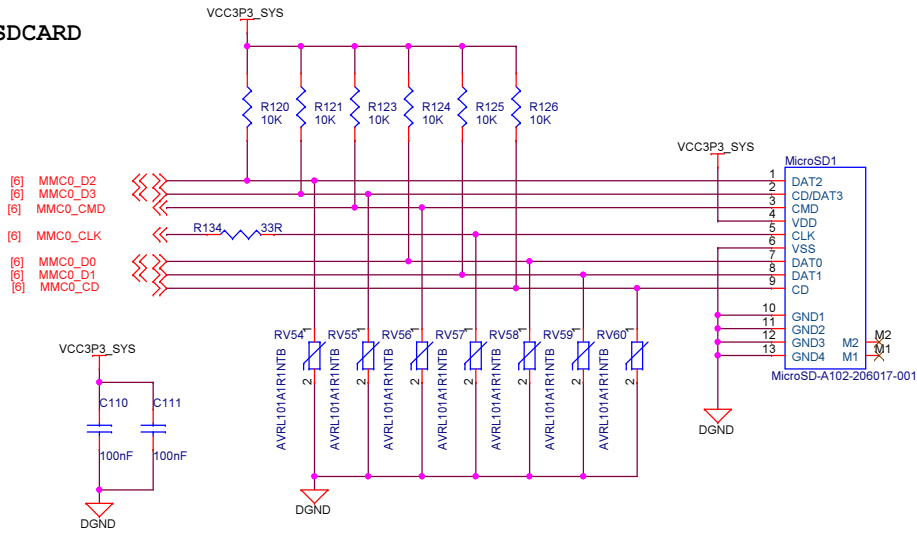

RGB LCD Interface

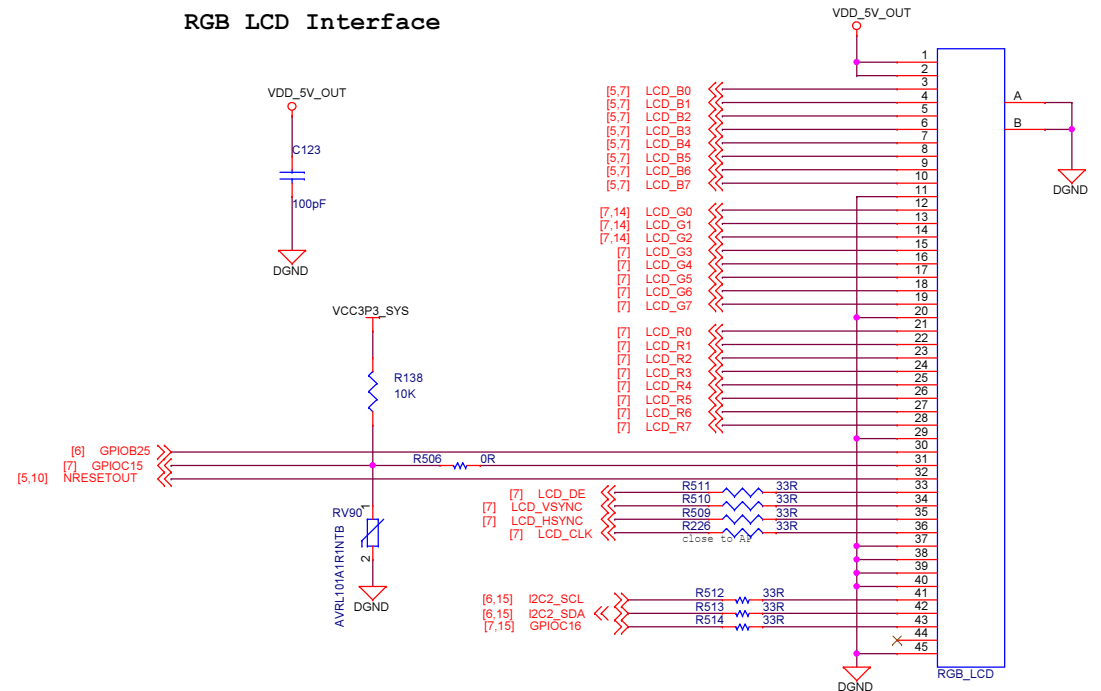

PCB Version

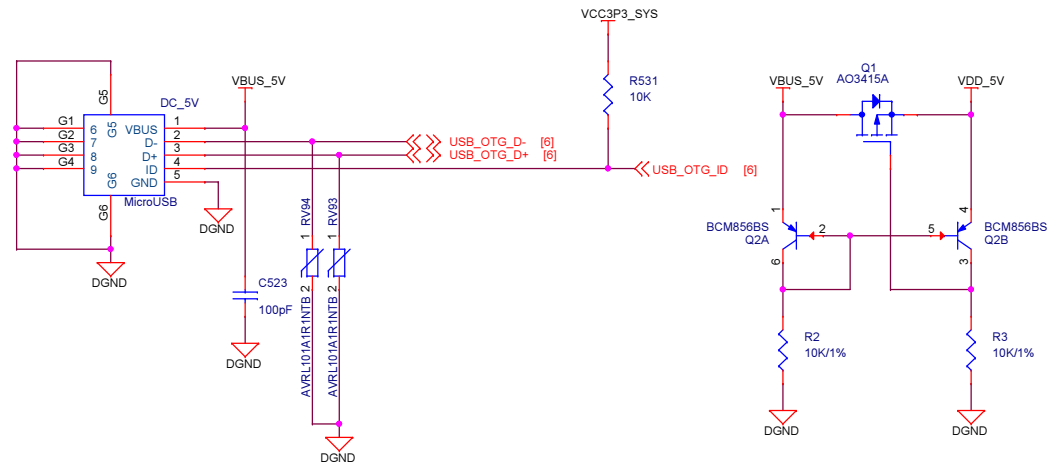
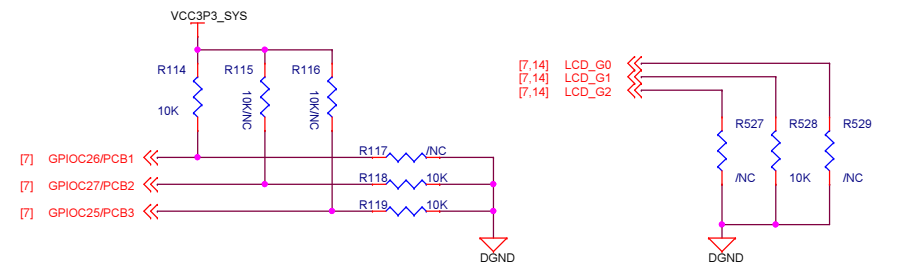

Core4418		
Size	Document Number	Rev
A3	10.MicroSD, RGB-LCD&Camera	<RevCode>
Date:	Wednesday, December 20, 2017	Sheet 14 of 15

2.54mm Header

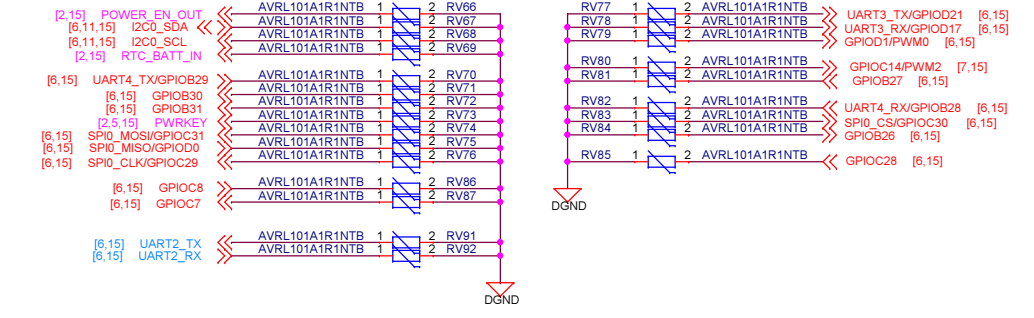
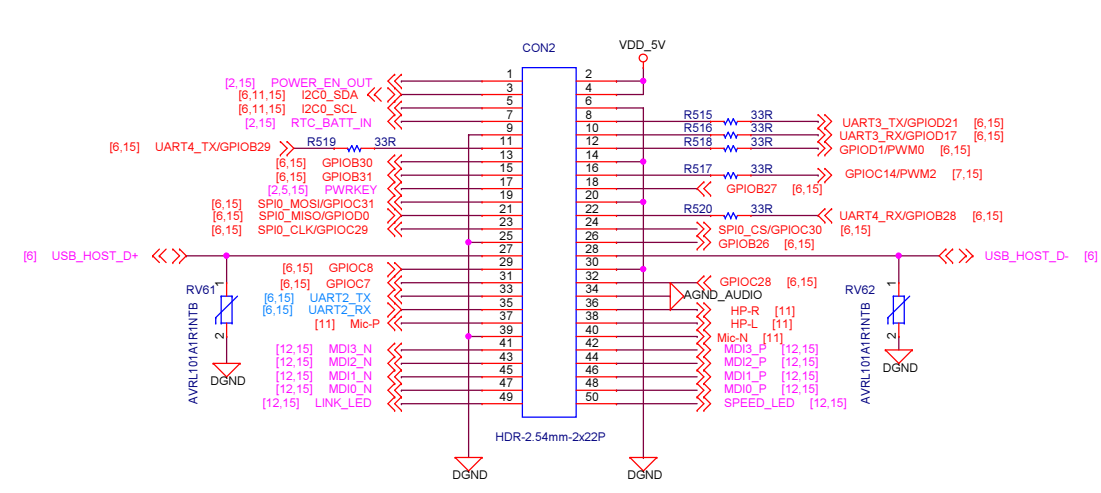

Debug UART

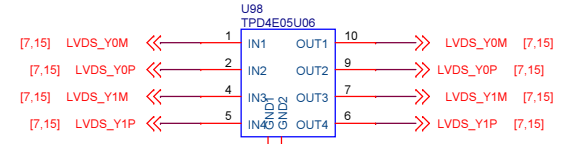
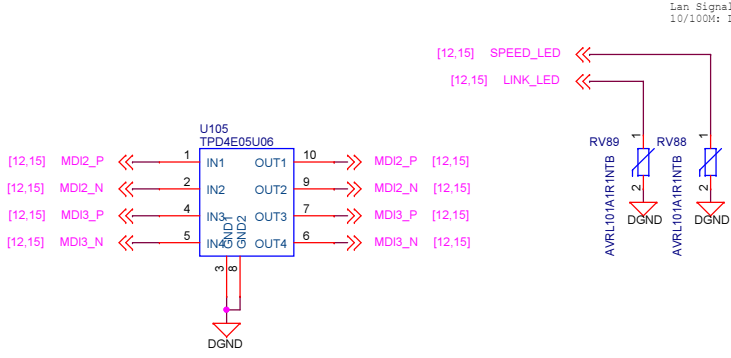
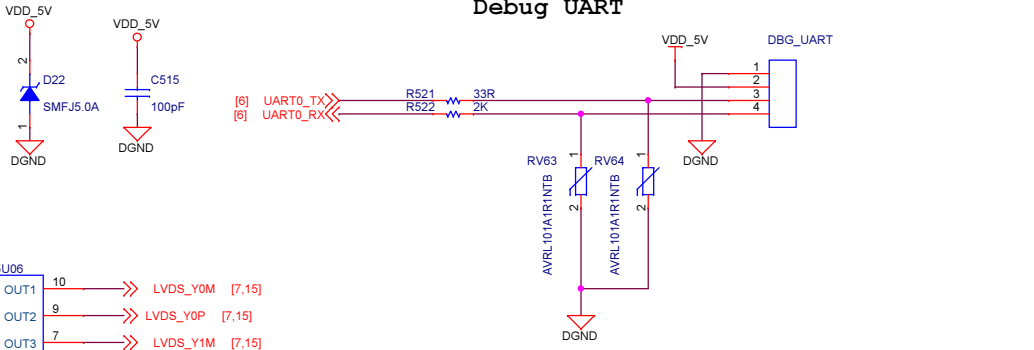

LVDS

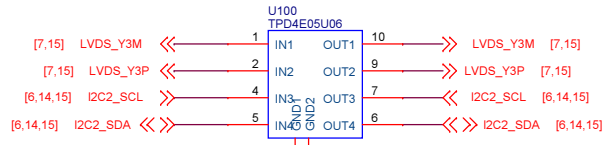
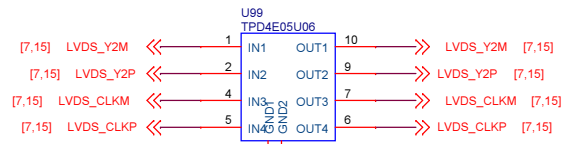
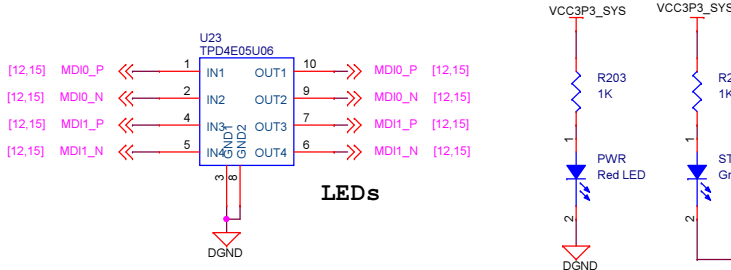
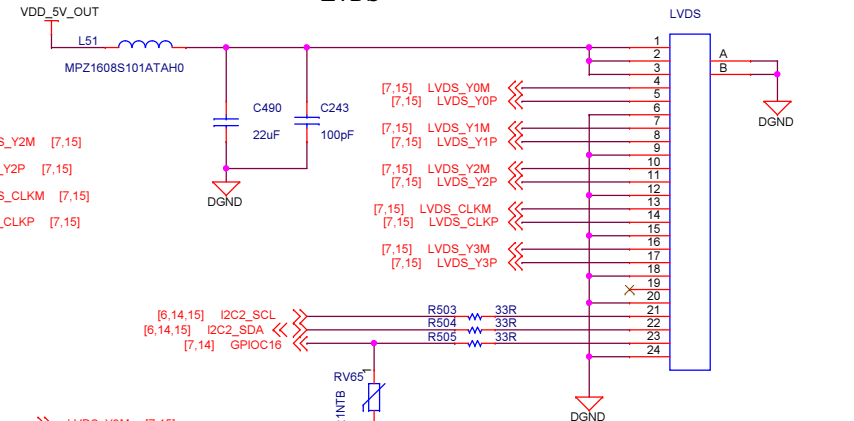

Core4418		
Size A3	Document Number 16.Header,USB,LEDs,Buttons,LVDS	Rev <RevCode>
Date: Wednesday, December 20, 2017	Sheet 15	of 15