

# SOM-RK3399 Development Kit

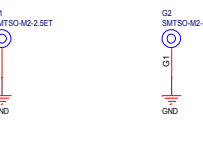

SOM-RK3399 Development Kit		
Size A3	Document Number 01.Title	Rev 1904
Date:	Wednesday, May 22, 2019	Sheet 1 of 17

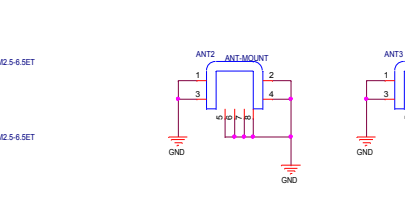

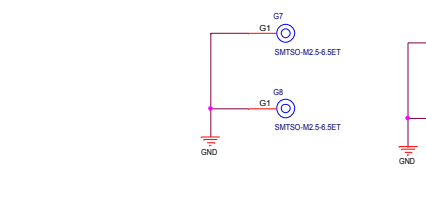
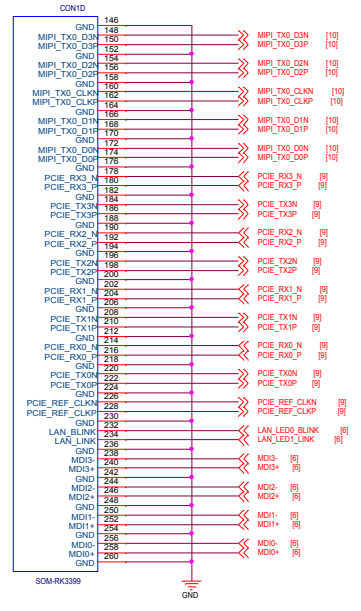
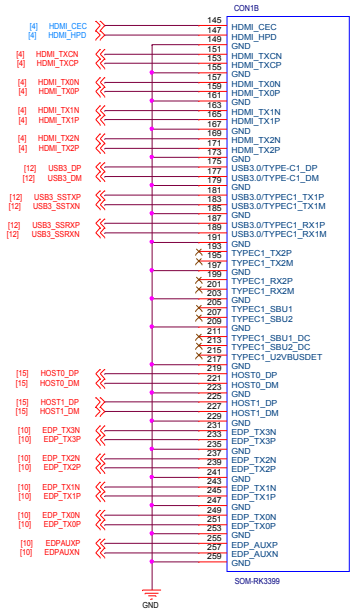
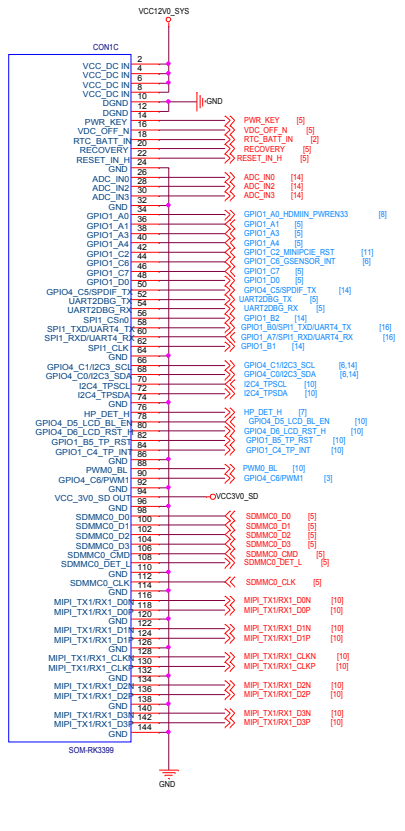
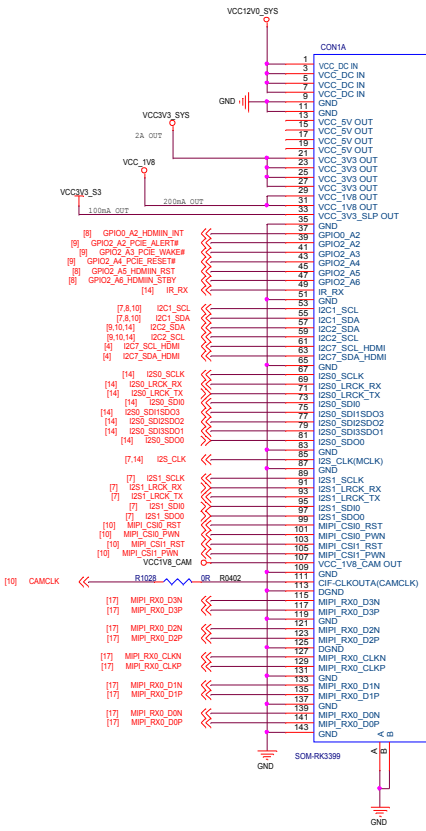
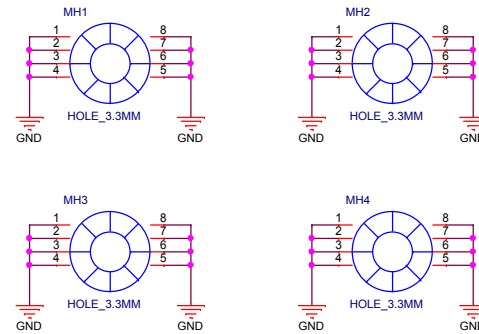
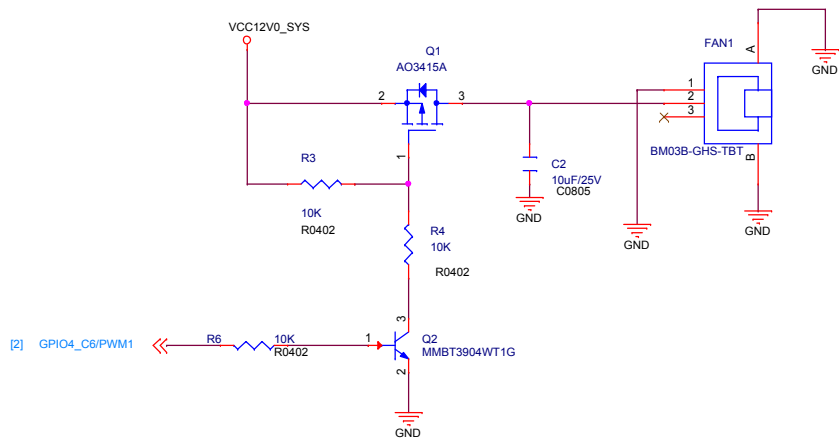
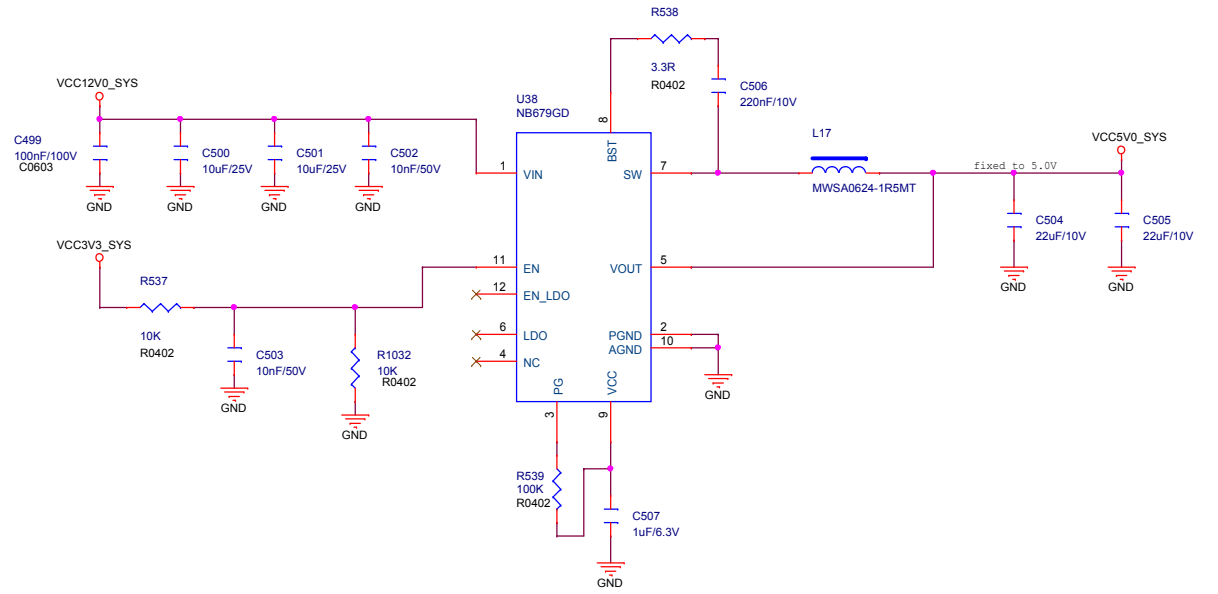
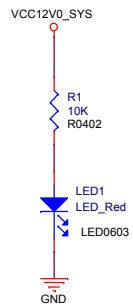
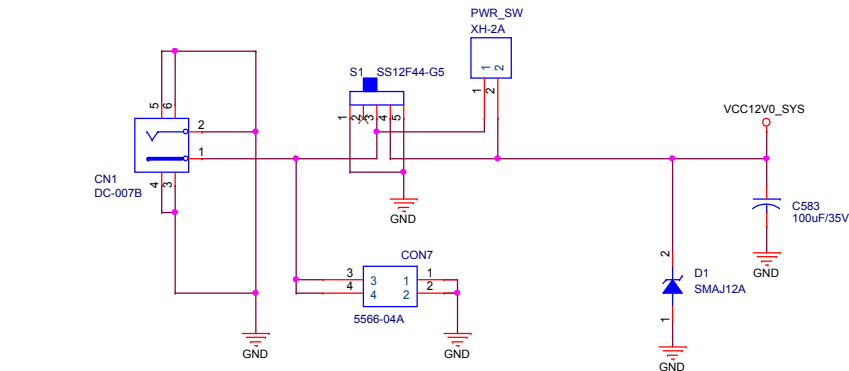

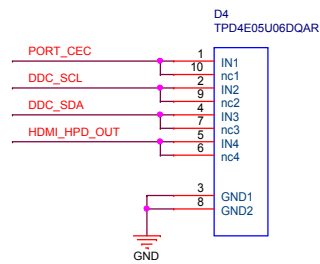
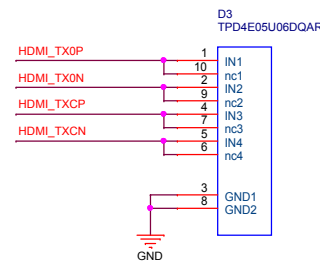
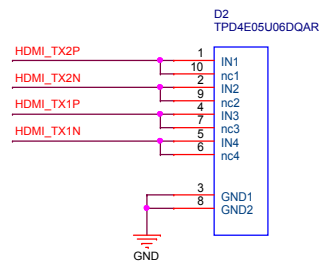
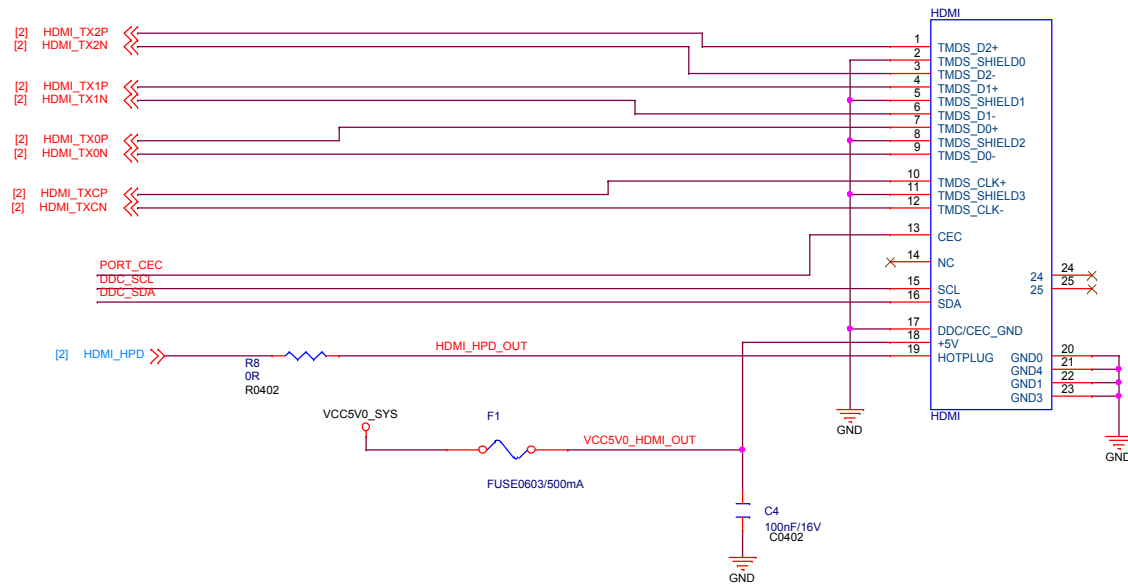
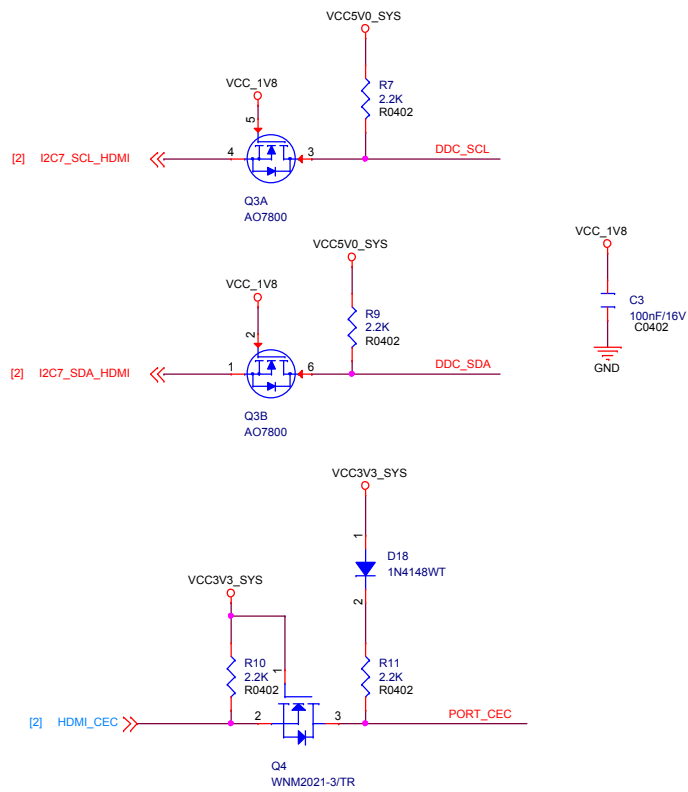

SOM-RK3399 Development Kit

Size A3	Document Number 04.HDMI OUT	Rev 1904
Date:	Wednesday, May 22, 2019	Sheet 4 of 17

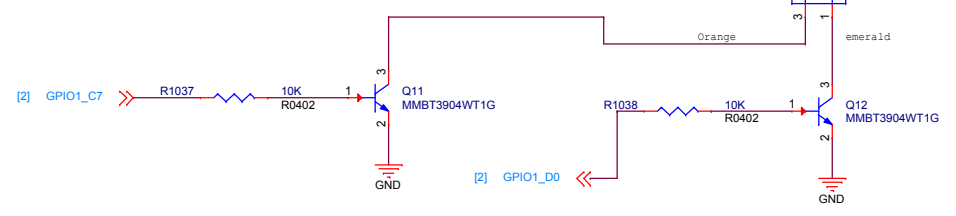
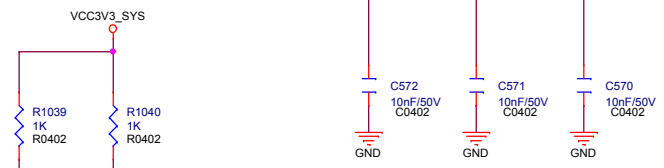
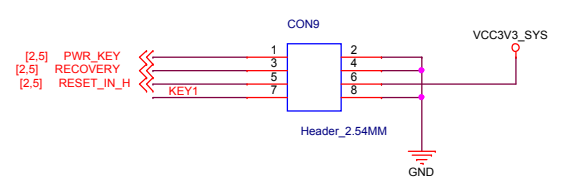
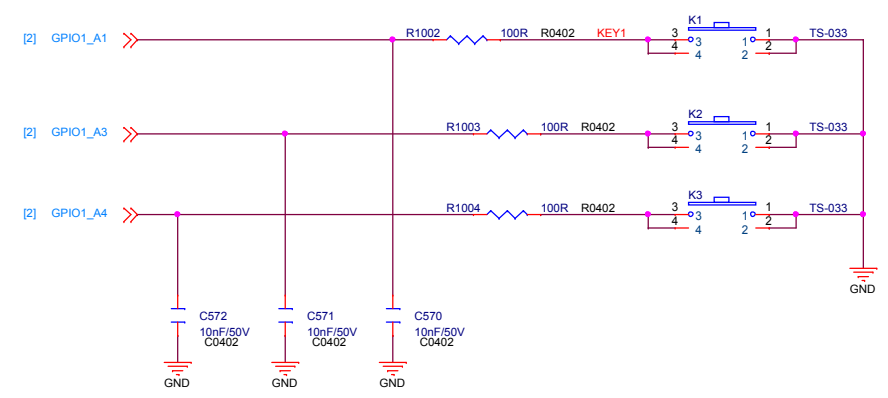
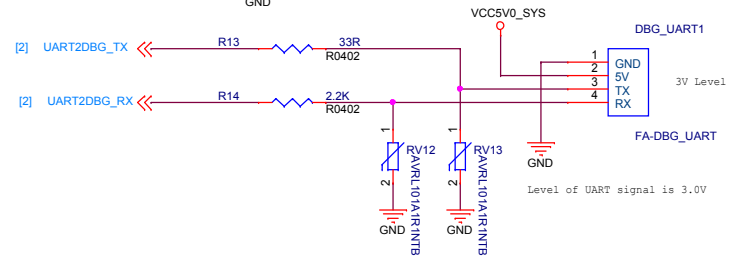
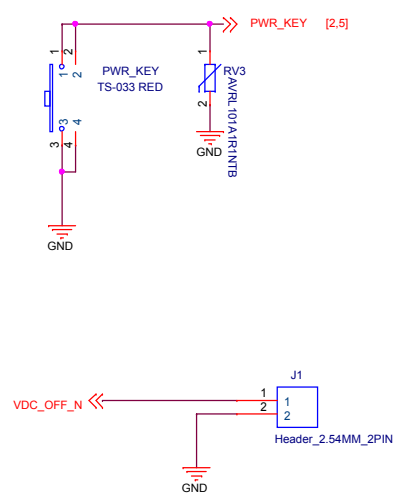
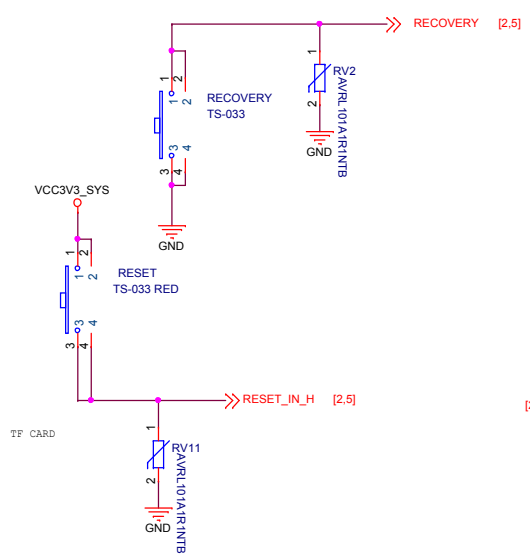
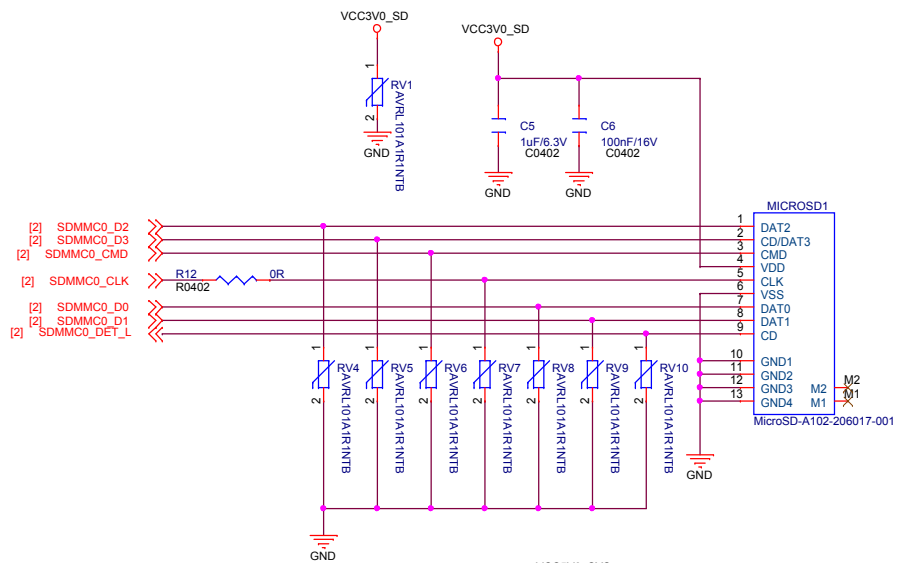

SOM-RK3399 Development Kit		
Size A3	Document Number 05.SD/DBG/KEYs	Rev 1904
Date: Wednesday, May 22, 2019	Sheet 5 of 17	

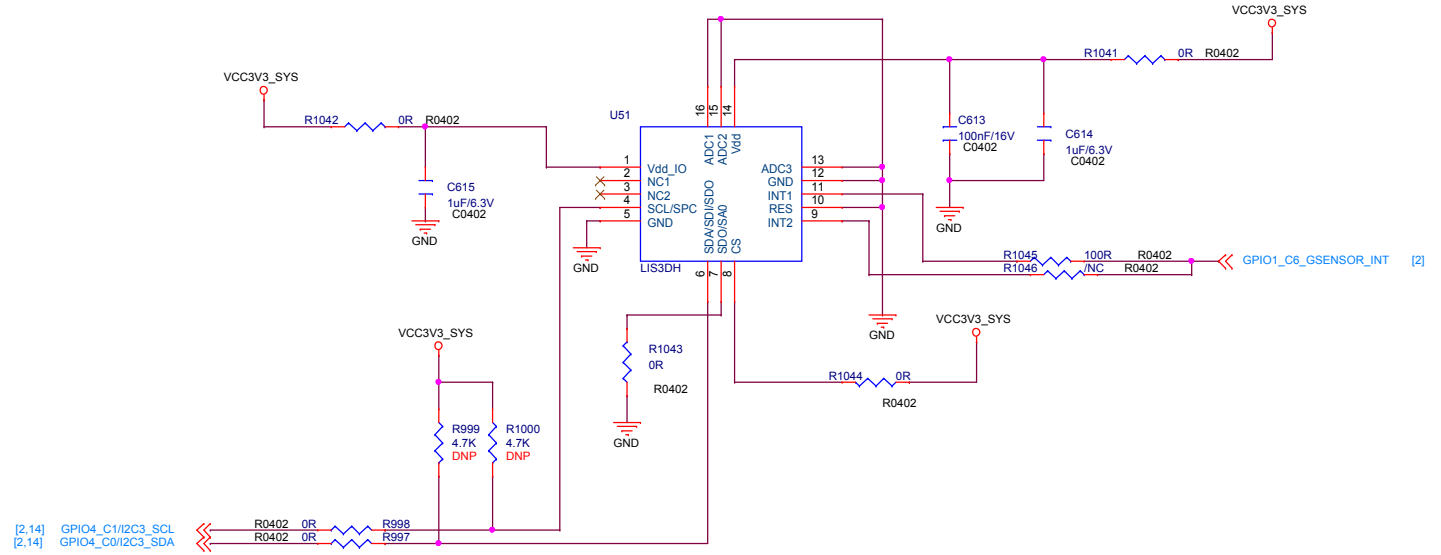
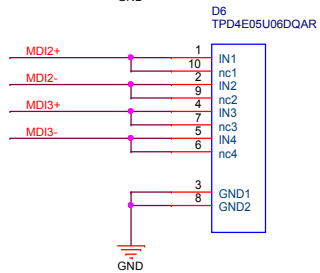
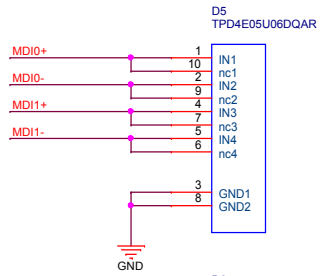
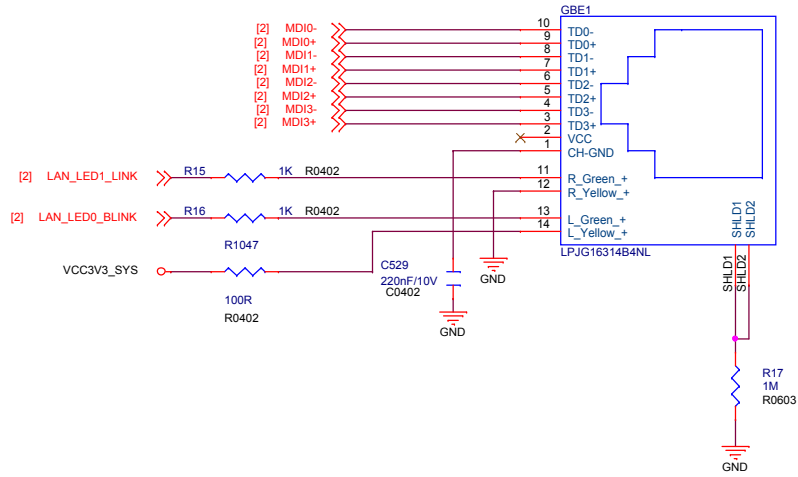

# Audio CODEC

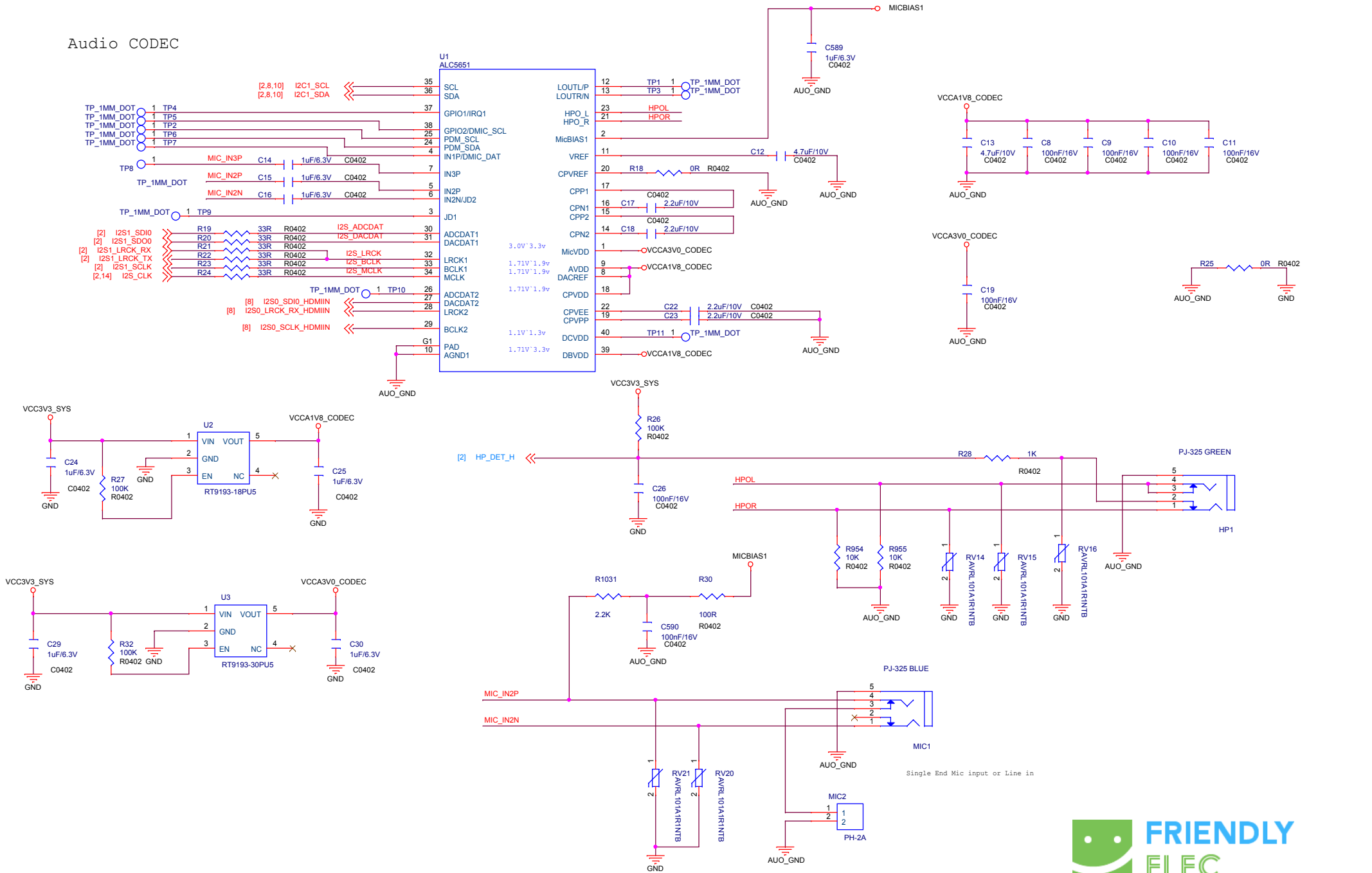

# HDMI INPUT

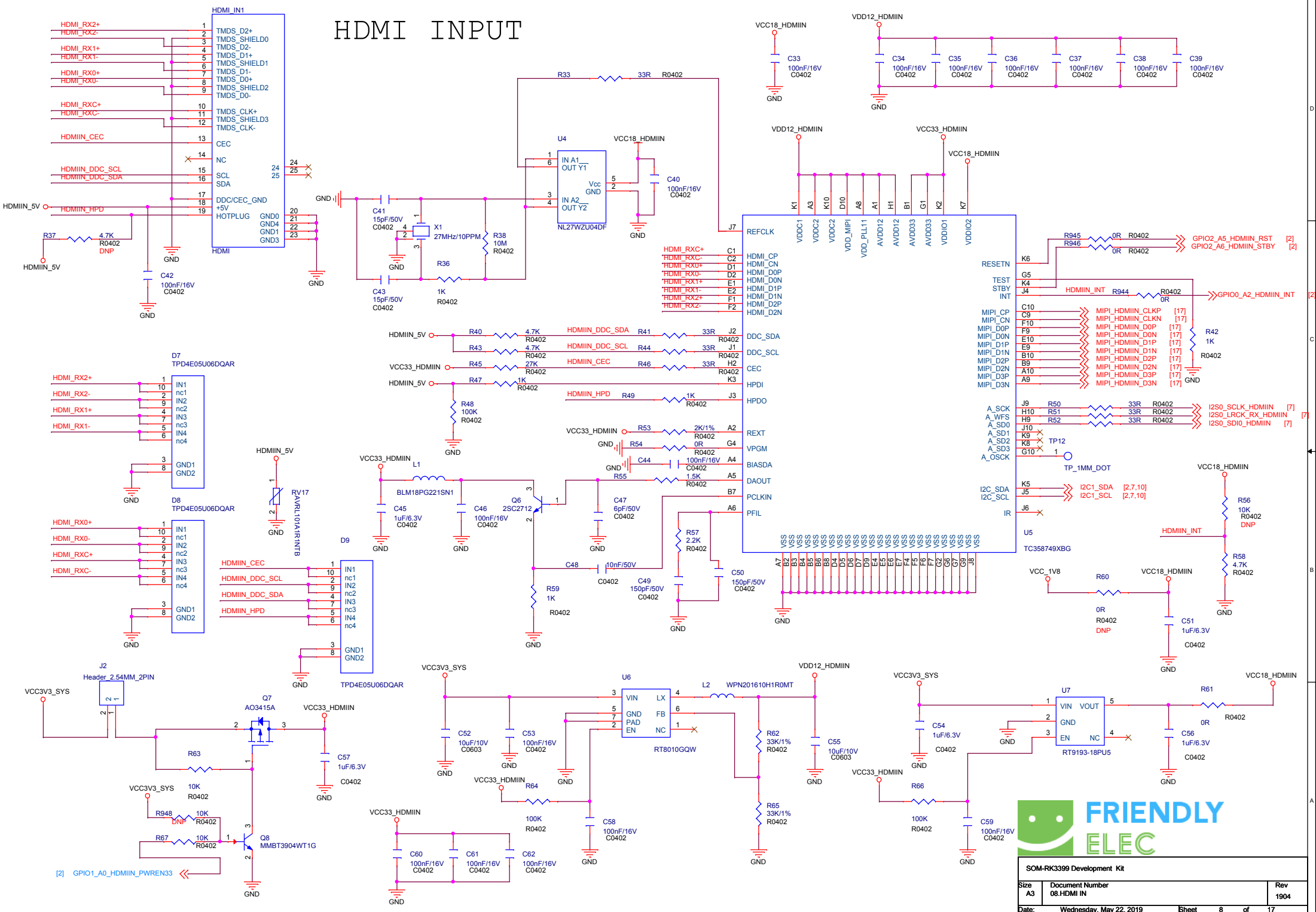



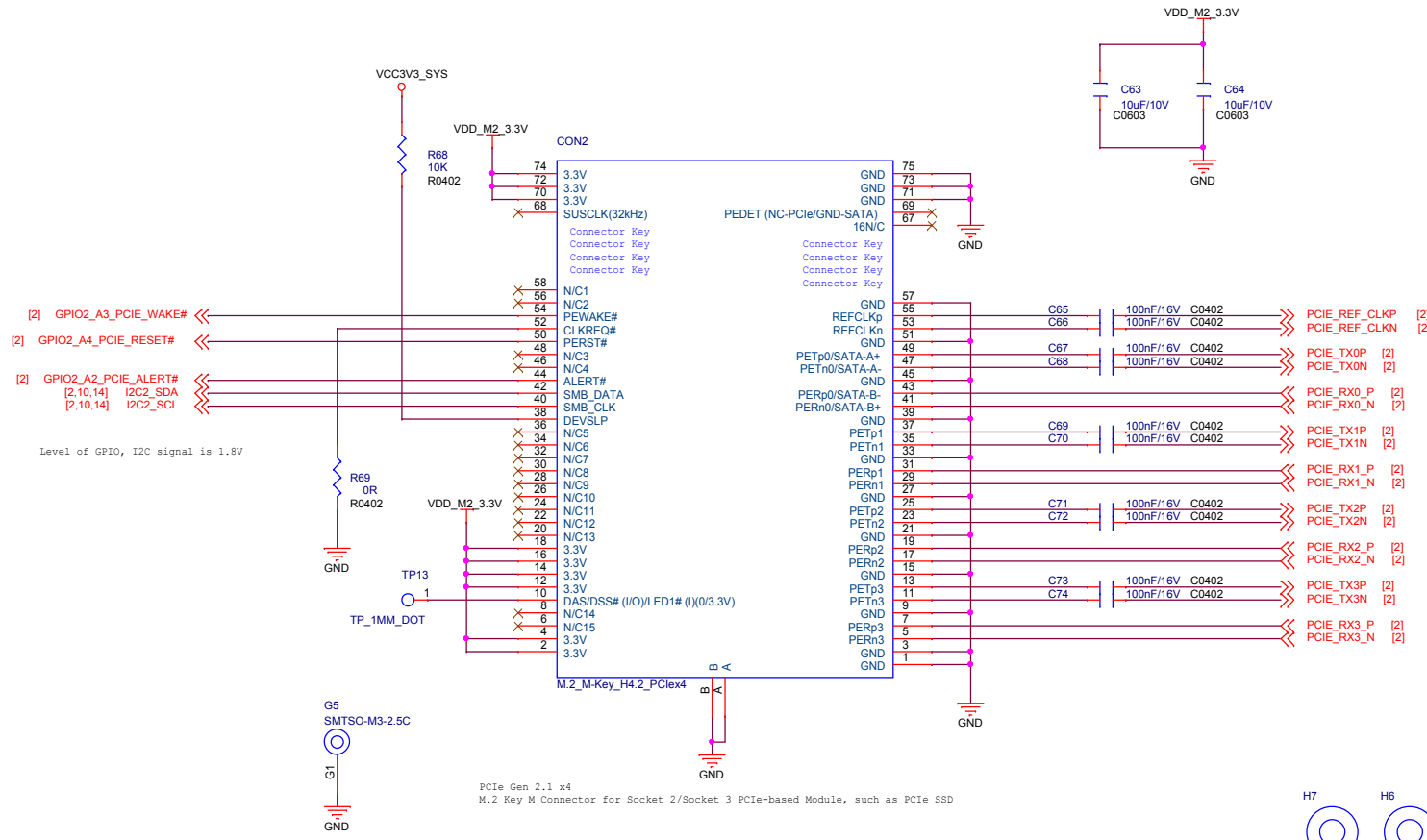

PCIe Gen 2.1 x4  
M.2 Key M Connector for Socket 2/Socket 3 PCIe-based Module, such as PCIe SSD

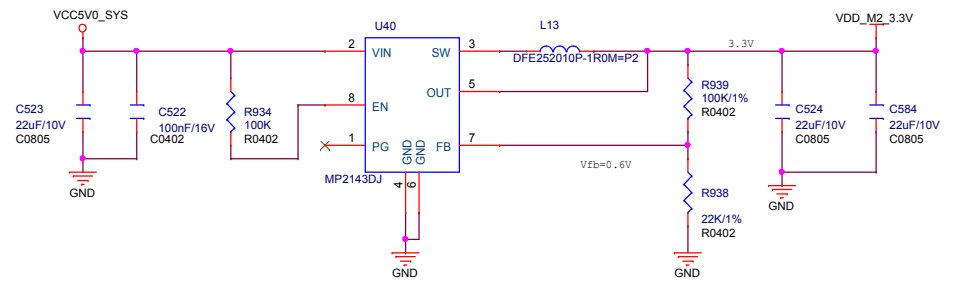
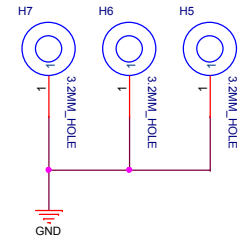

SOM-RK3399 Development Kit		
Size A3	Document Number 09.PCIE/M.2	Rev 1904
Date: Wednesday, May 22, 2019	Sheet 9	of 17

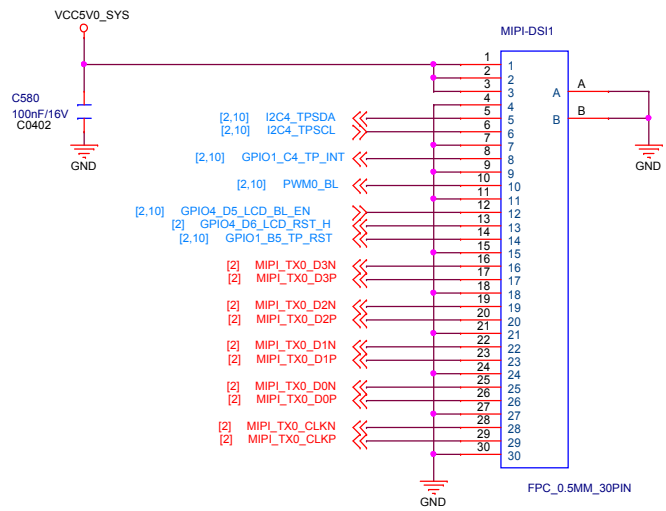

Level of GPIOs, PWM, and I2C signal is 3.0V

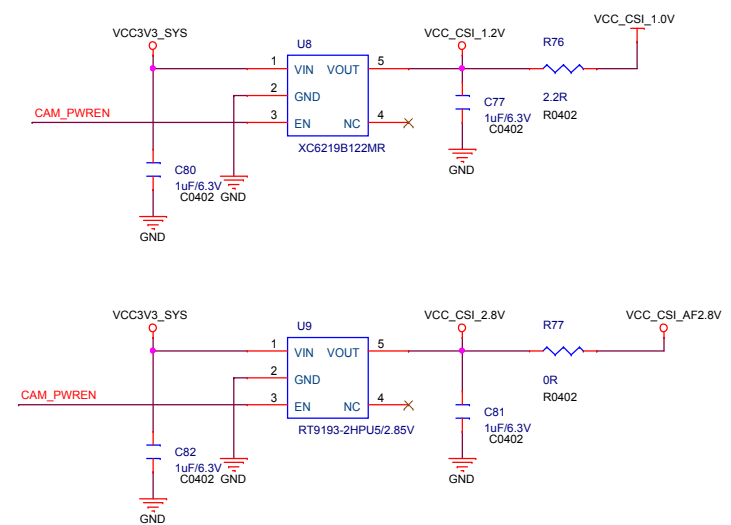
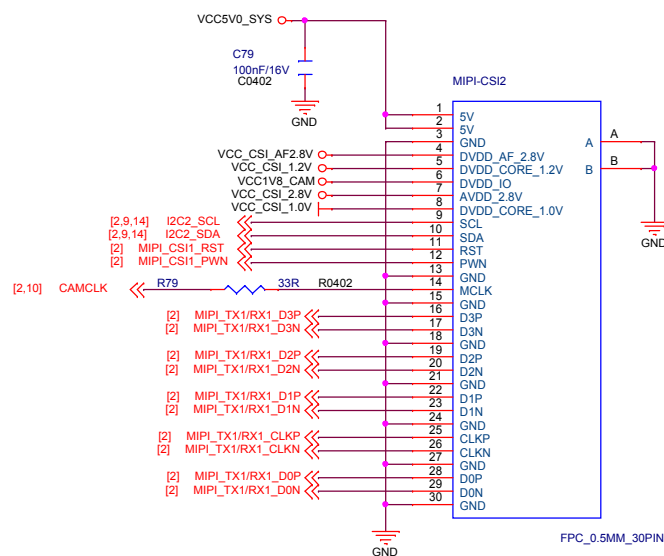
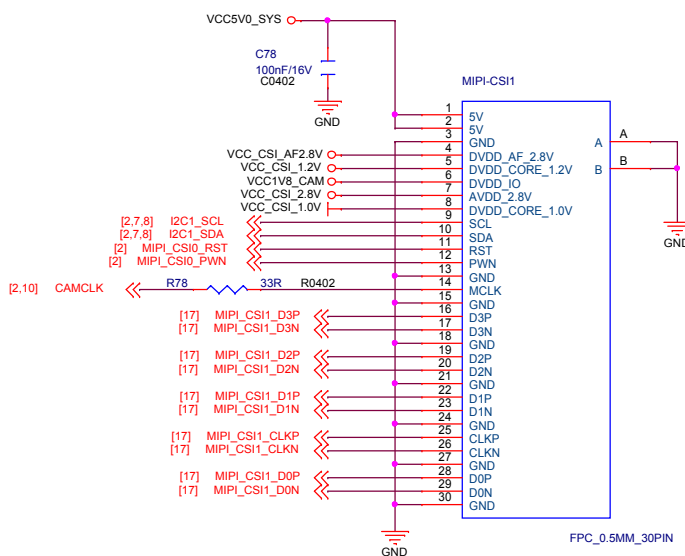
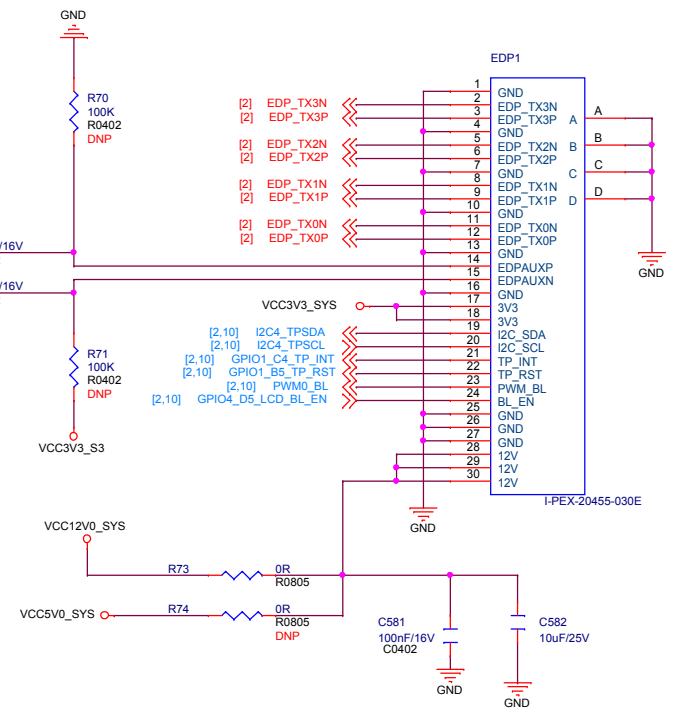
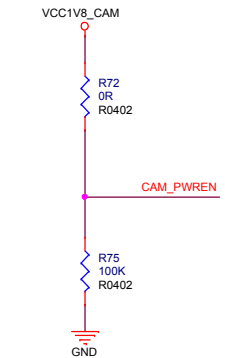
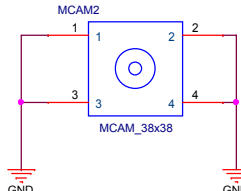
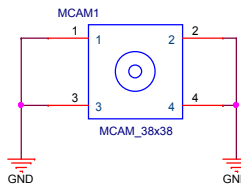

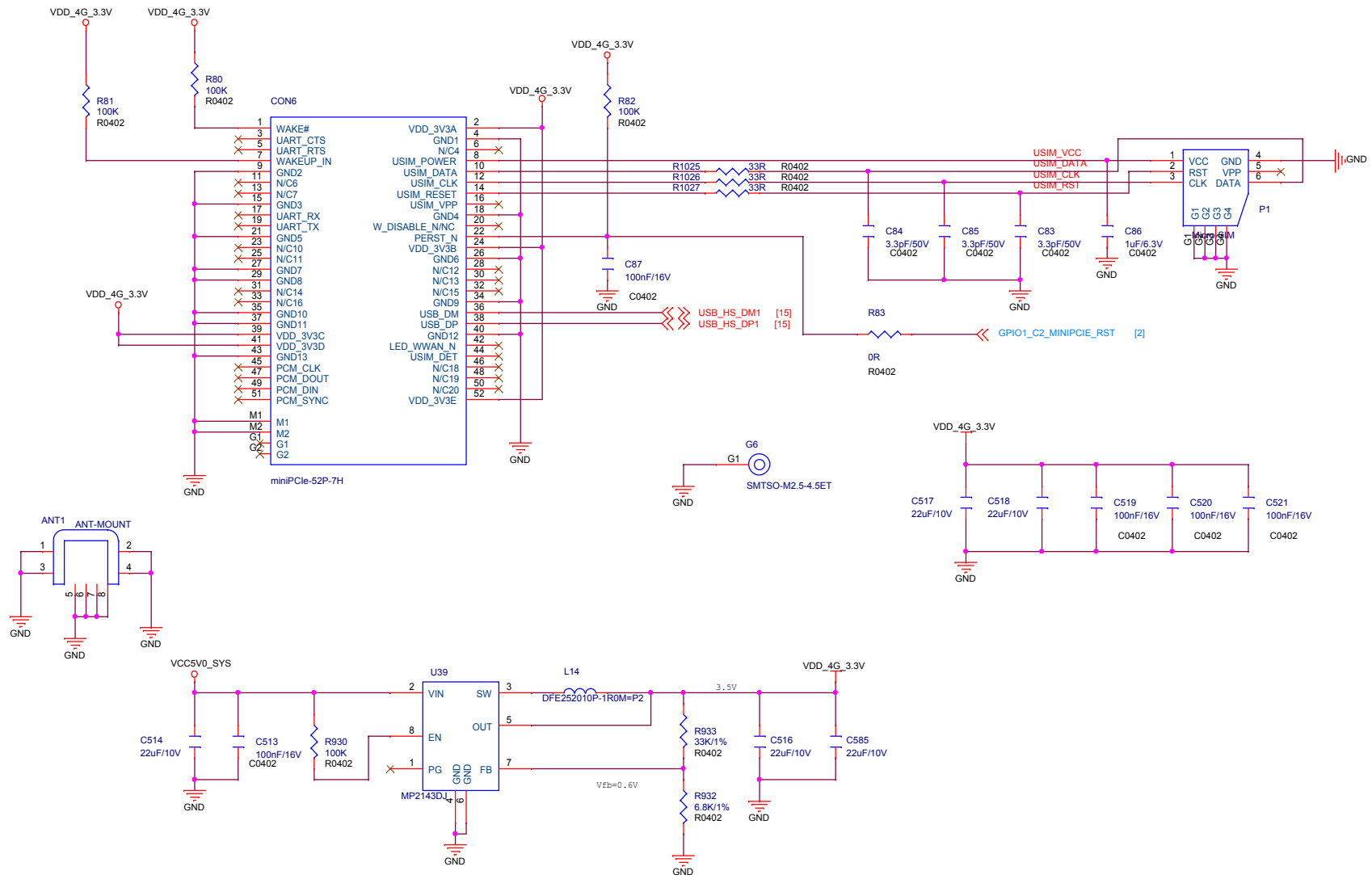

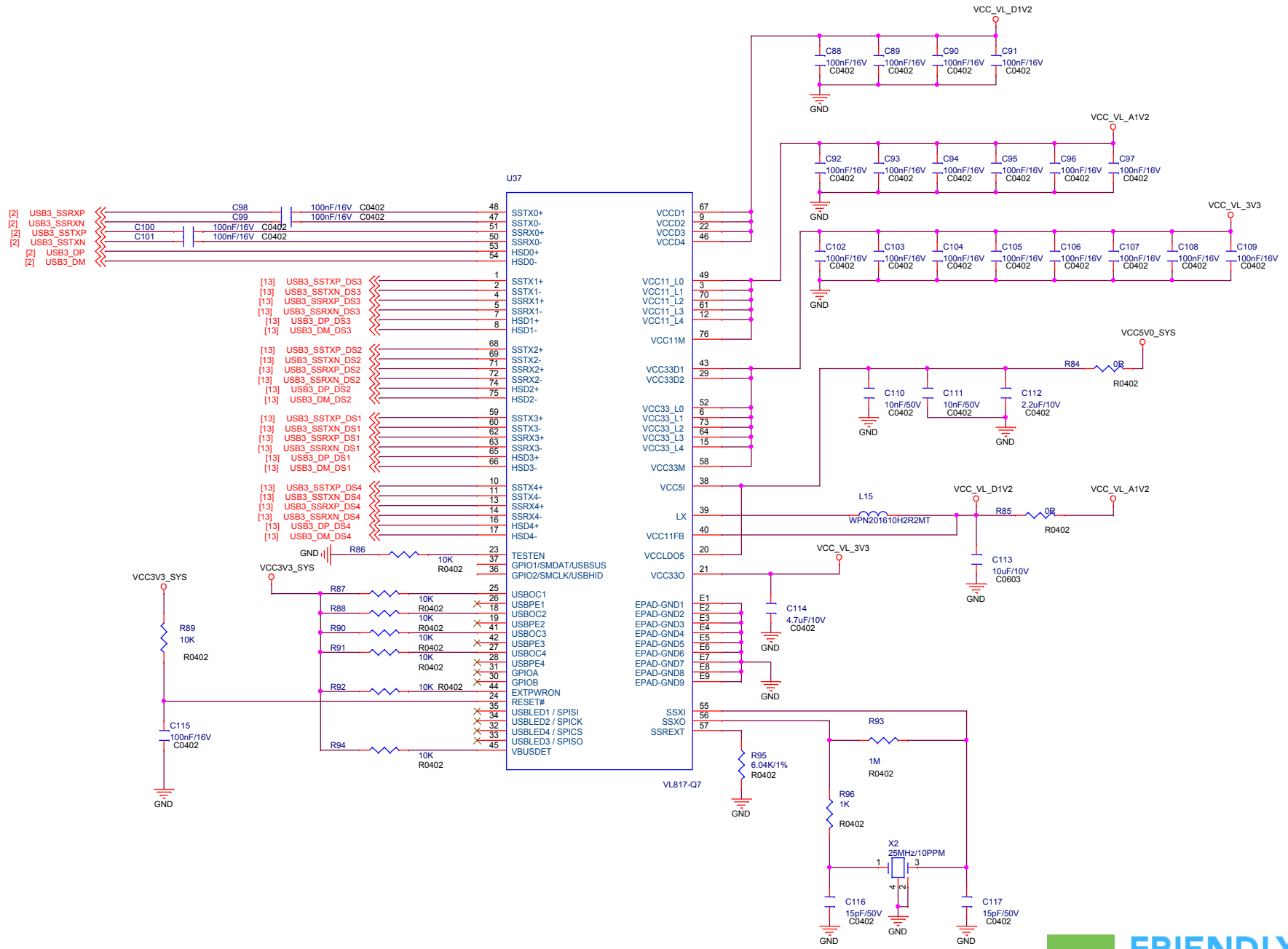

# USB3.0 Host

