

SOM-RK3399

Revision

1904 , First Release



| | | |
|------------|-----------------------------|---------------|
| SOM-RK3399 | | |
| Size A3 | Document Number 01.Title | Rev 1904 |
| Date: | Wednesday, May 22, 2019 | Sheet 1 of 20 |

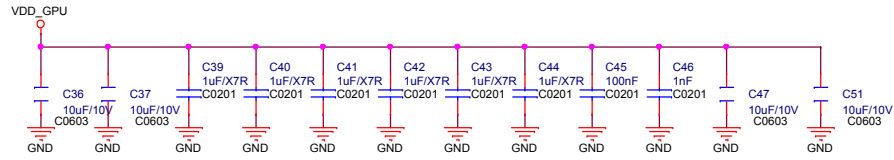
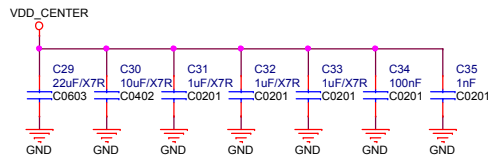
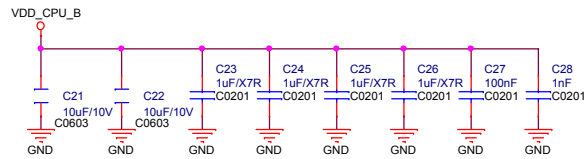
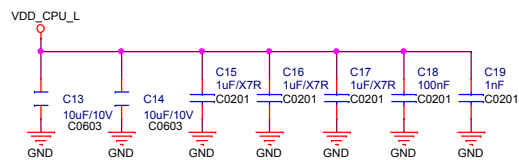
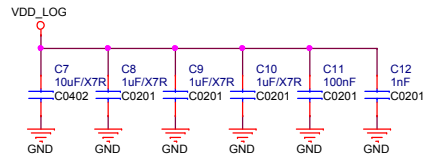
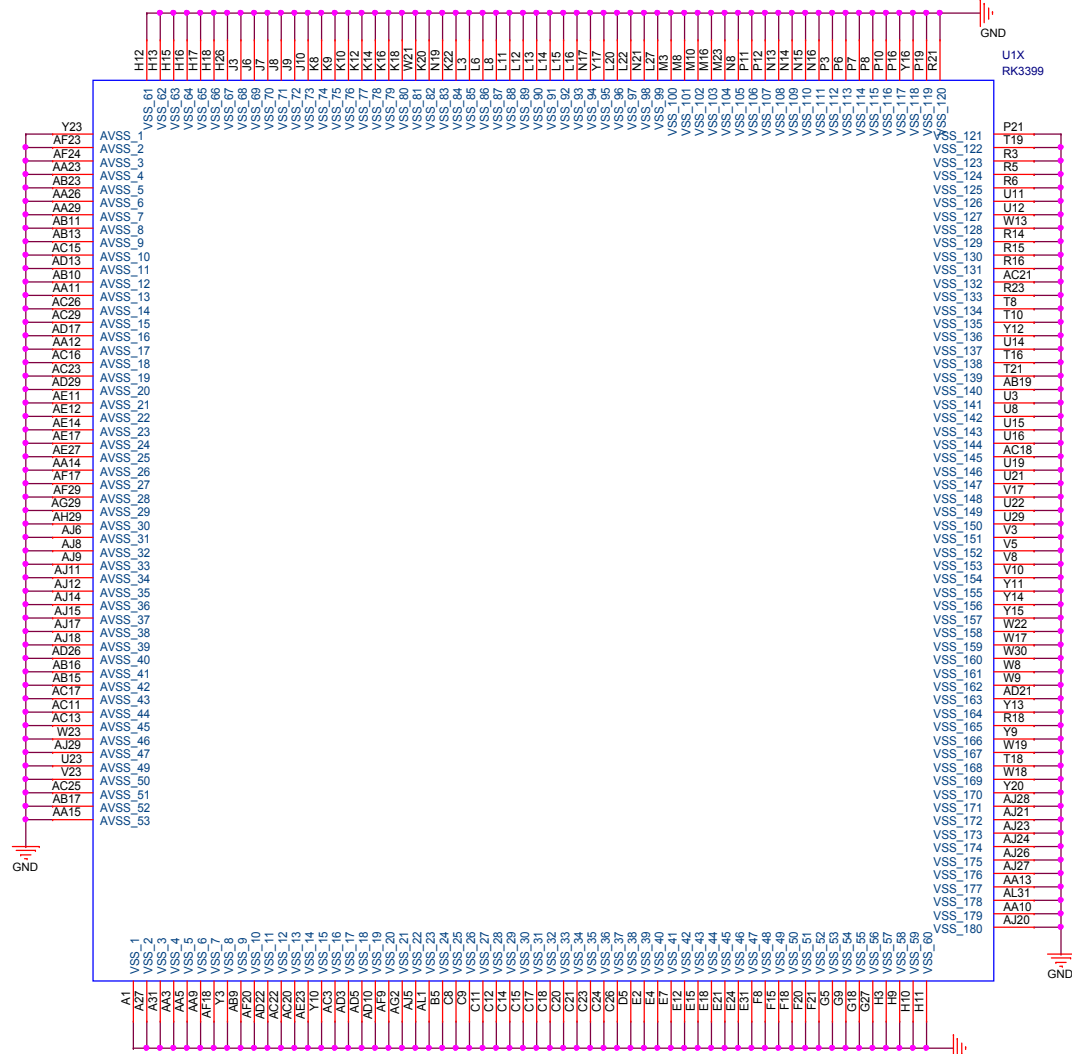
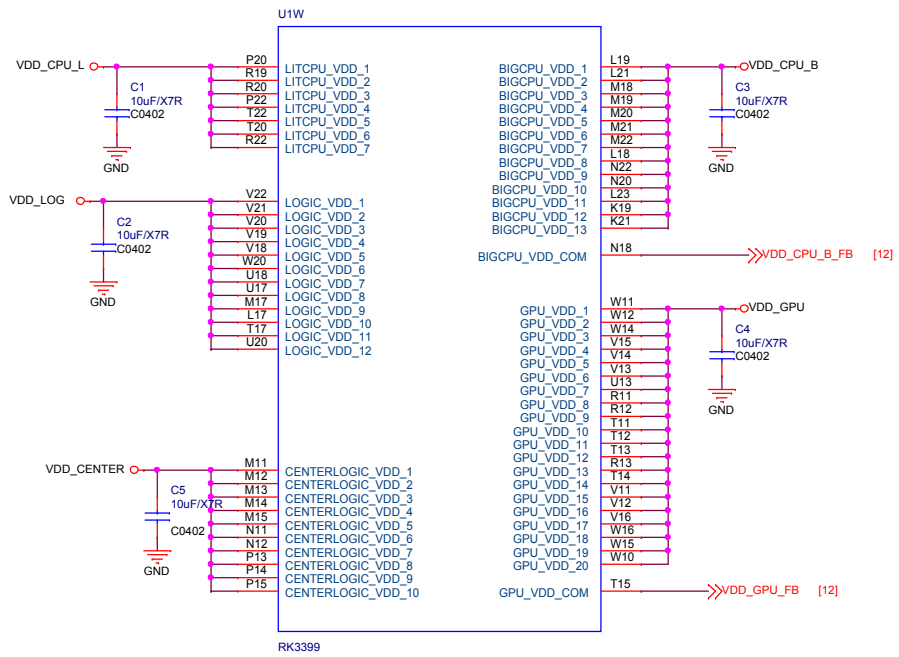

| | | |
|-------------------------------|---------------------------------|----------|
| SOM-RK3399 | | |
| Size A3 | Document Number 02.RK3399 Power | Rev 1904 |
| Date: Wednesday, May 22, 2019 | Sheet 2 of 20 | |

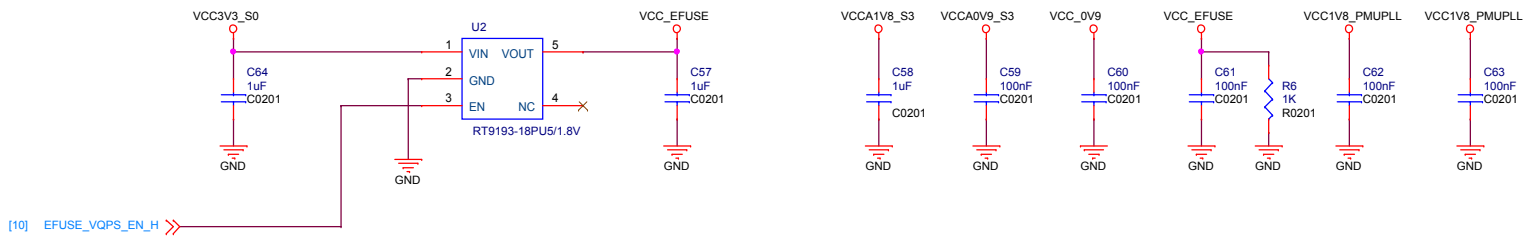
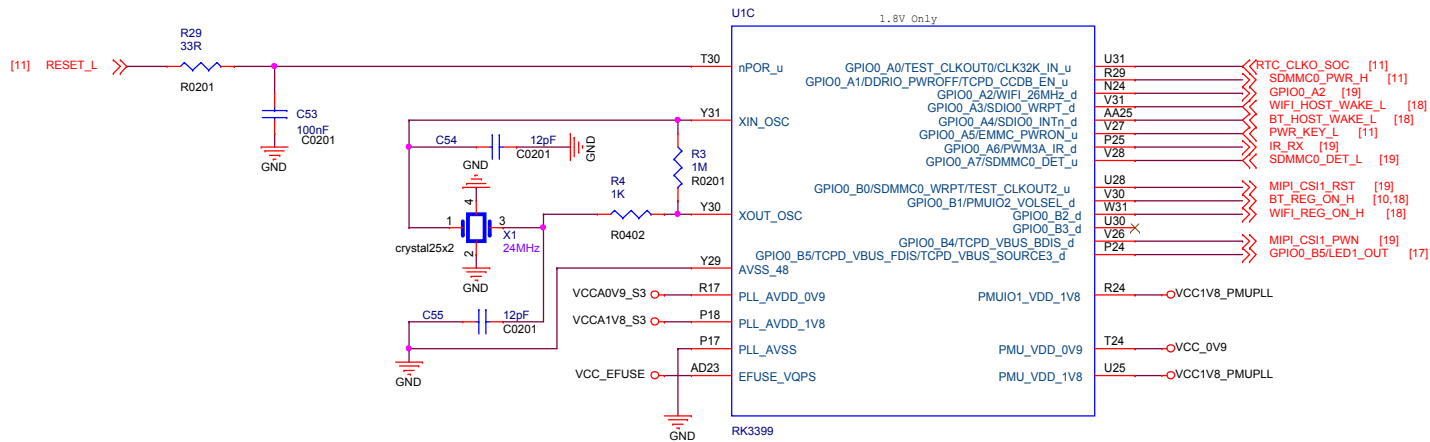

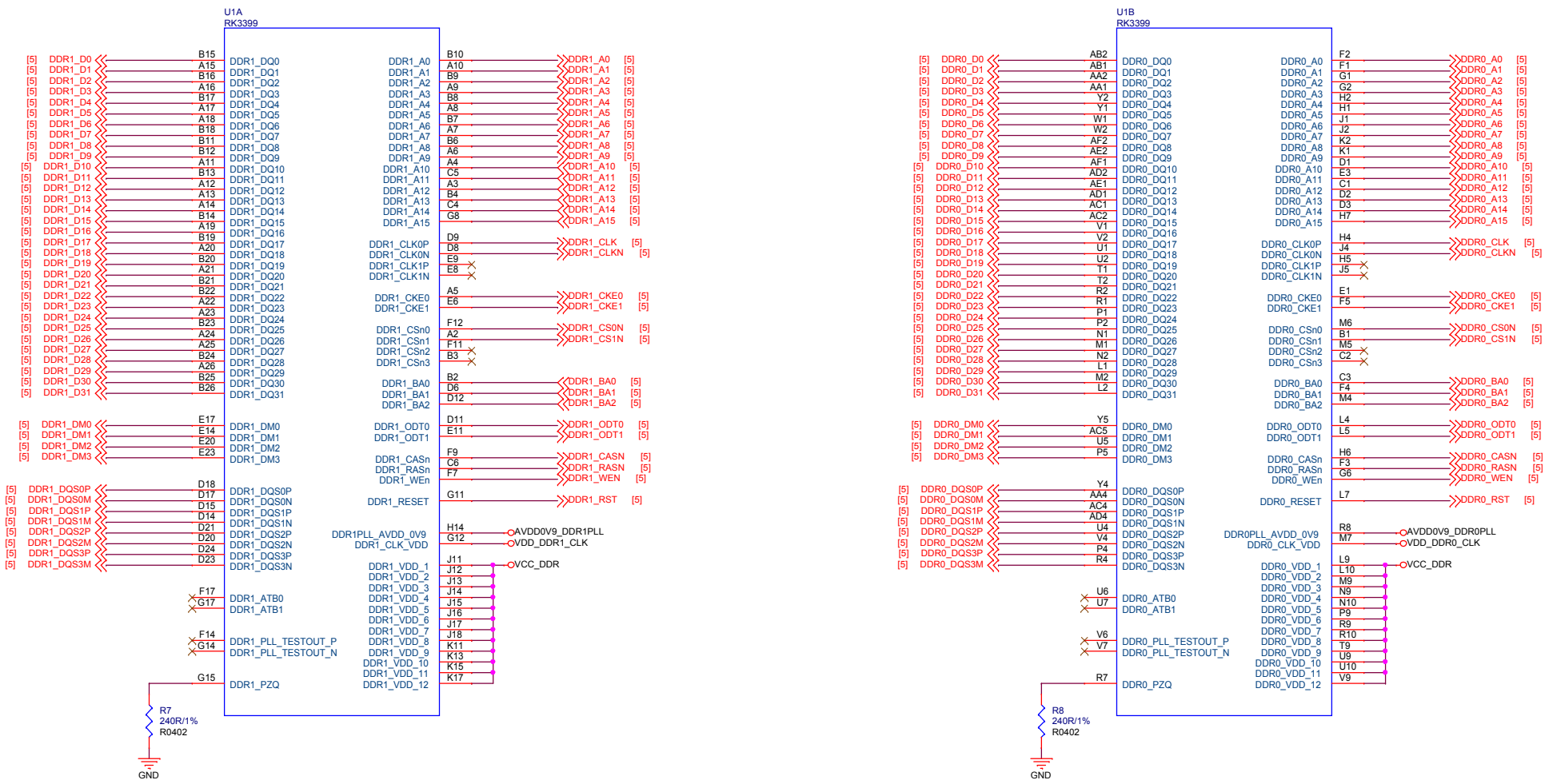

DDR FILTER

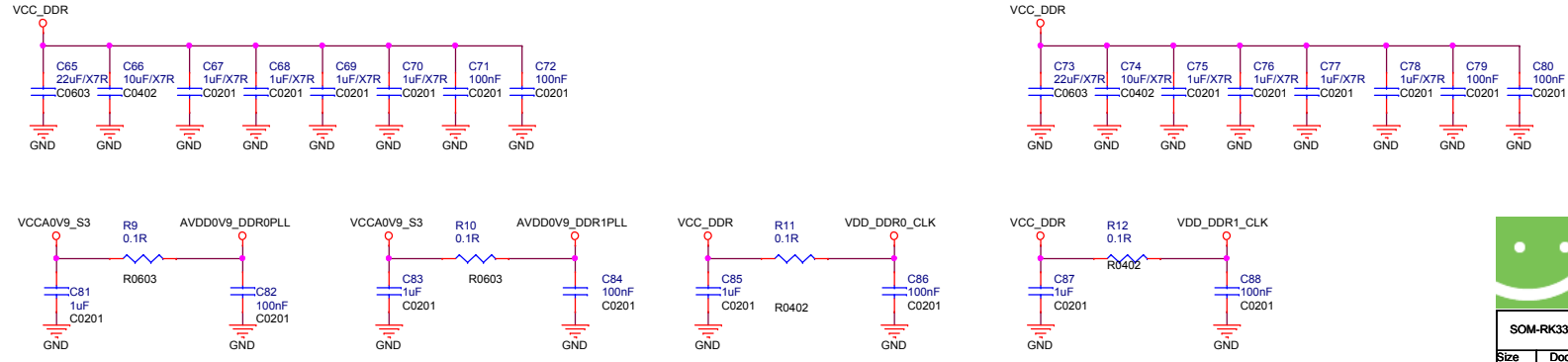

| | | |
|-------------------------------|------------------------------------------|----------|
| SOM-RK3399 | | |
| Size A3 | Document Number 04.RK3399 DDR Controller | Rev 1904 |
| Date: Wednesday, May 22, 2019 | Sheet 4 | of 20 |

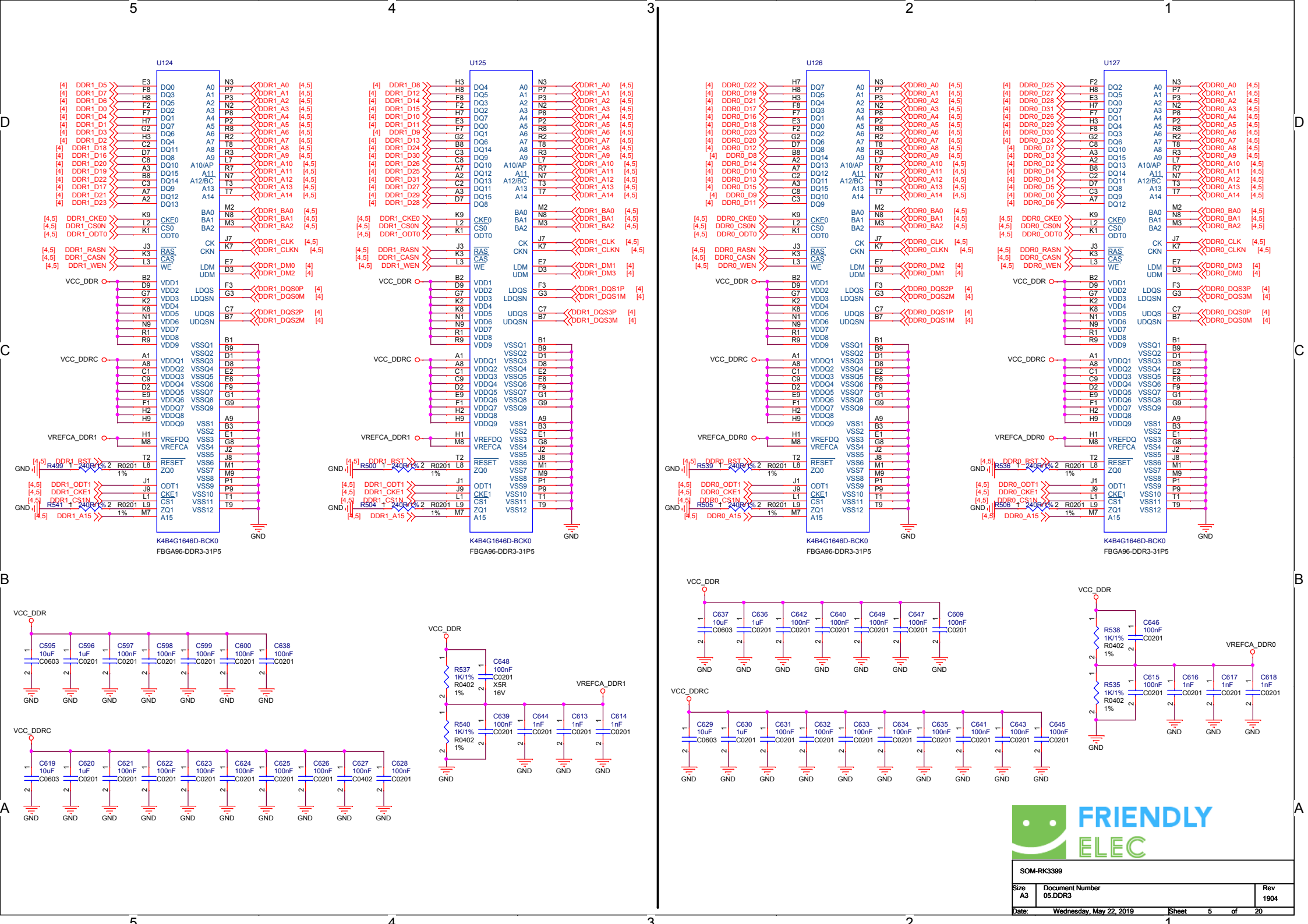

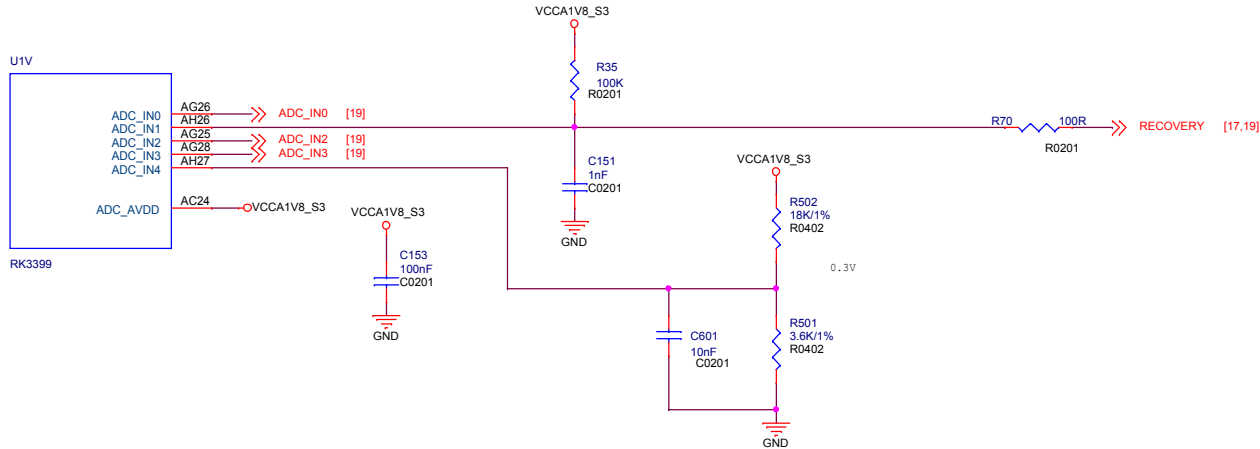
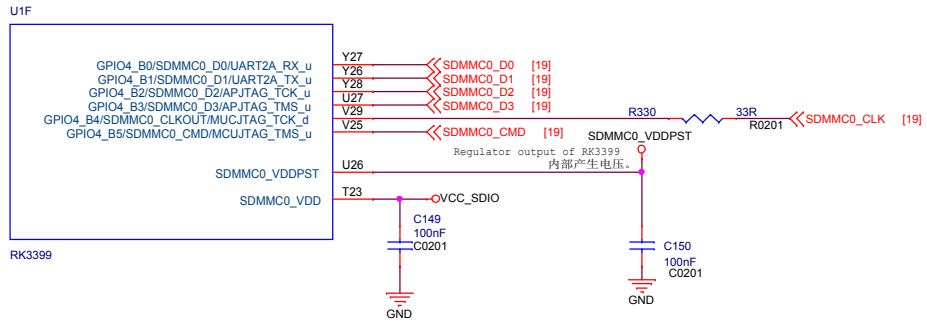
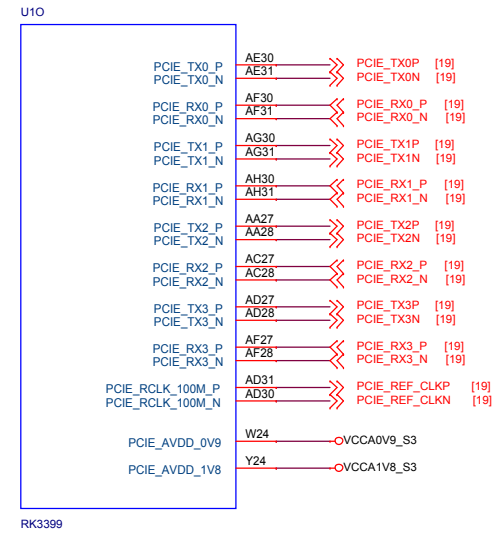
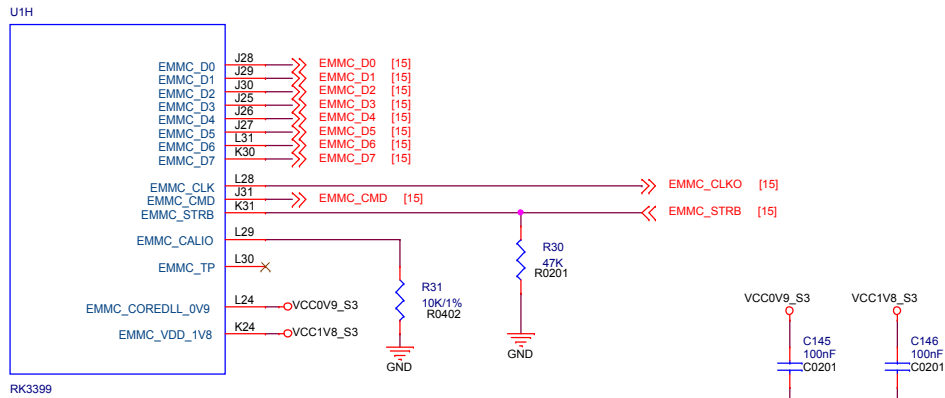

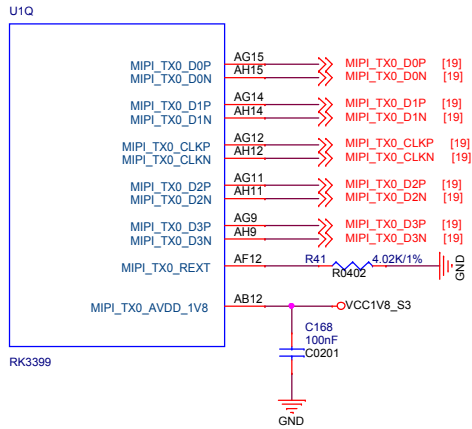
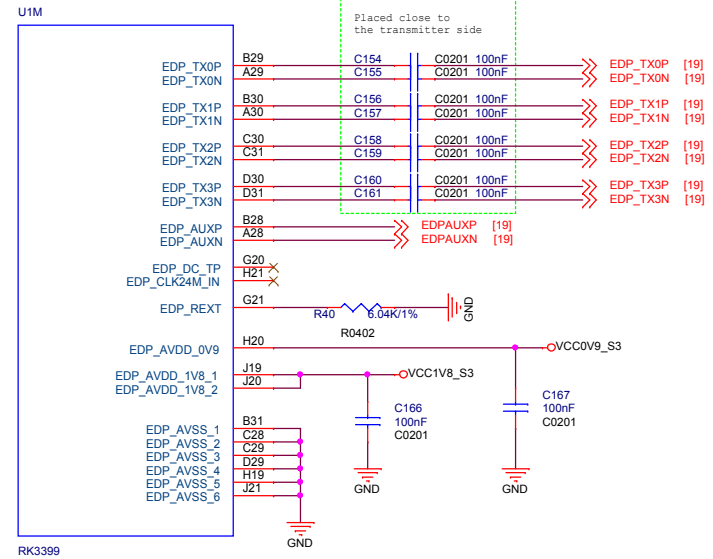
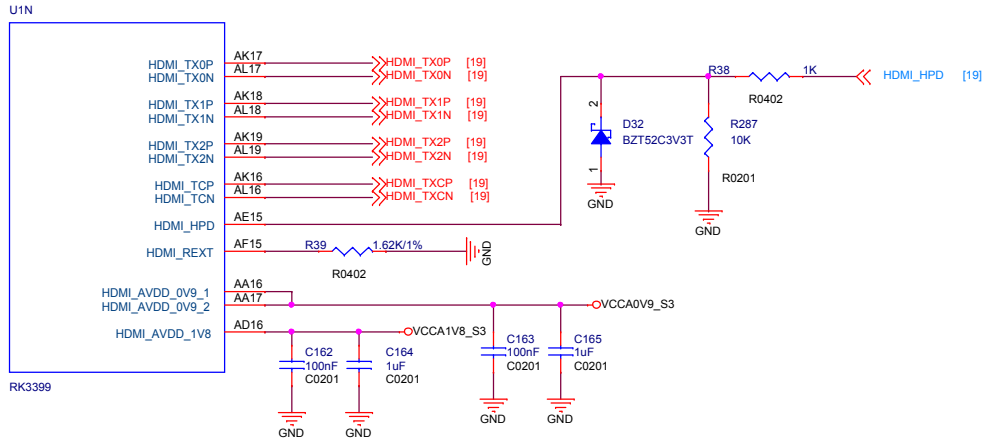

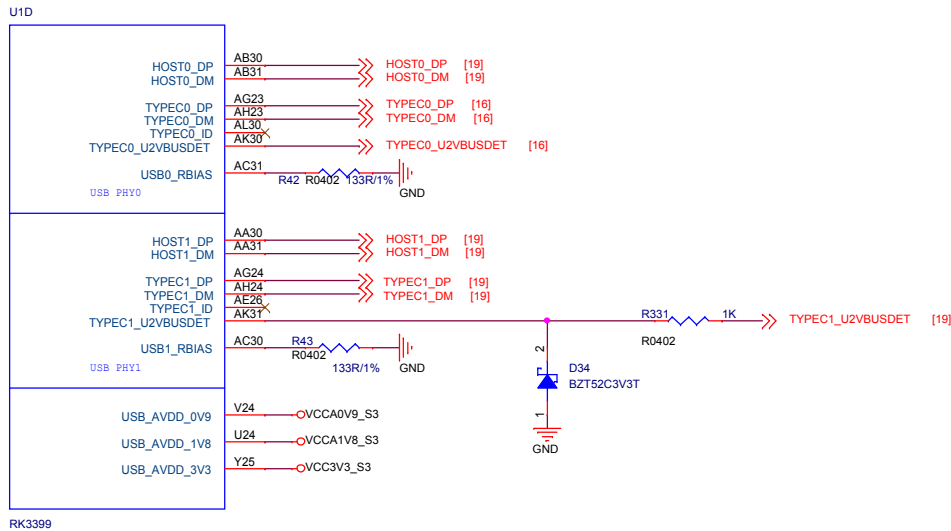

RK3399

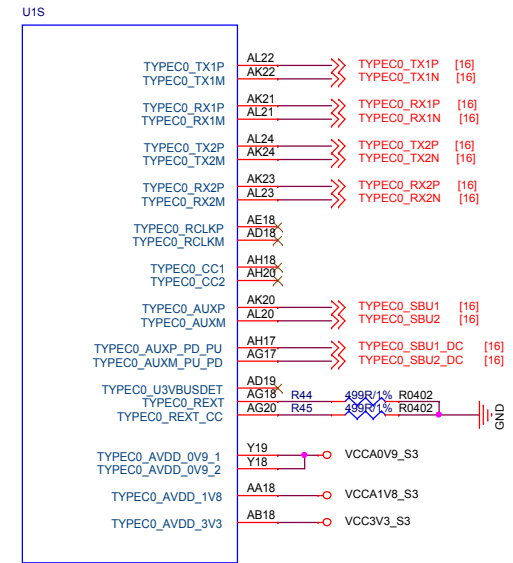
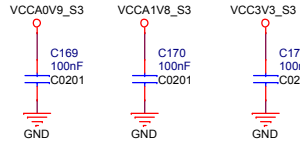

RK3399

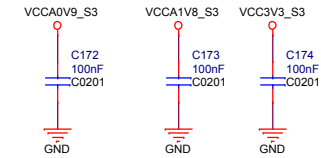

RK3399

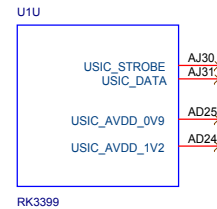
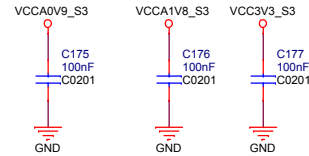

RK3399



SOM-RK3399

| | | |
|-------------------------------|-----------------------------------------------|----------|
| Size A3 | Document Number 09.RK3399 USB/USIC Controller | Rev 1904 |
| Date: Wednesday, May 22, 2019 | Sheet 8 | of 20 |

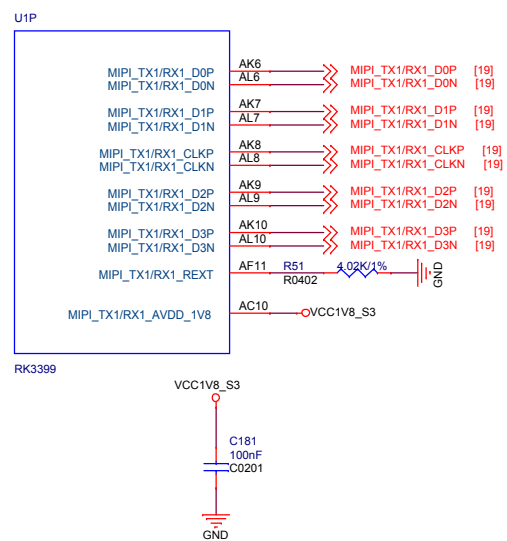
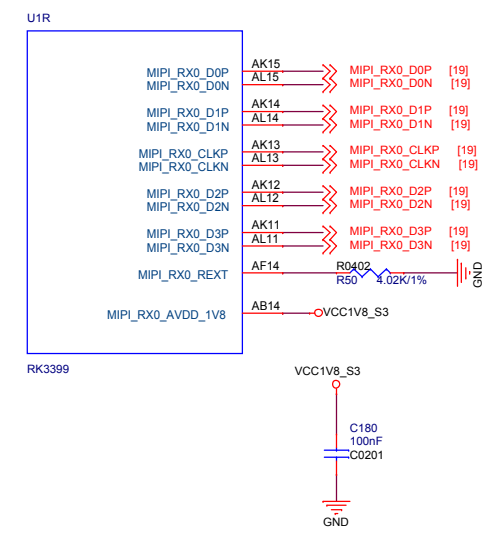
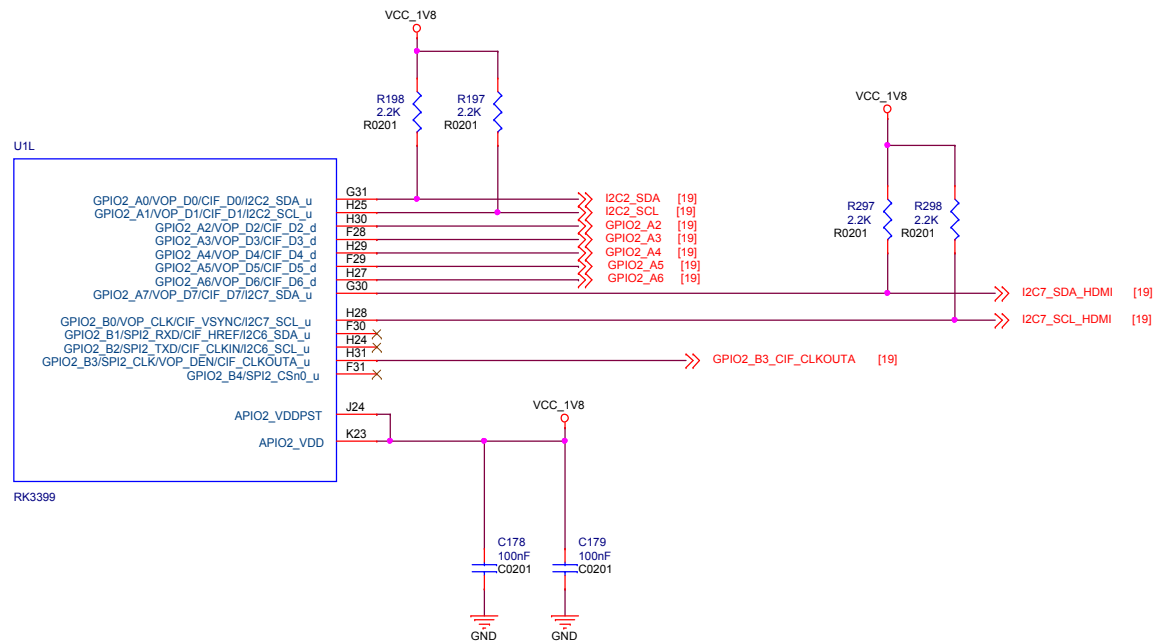

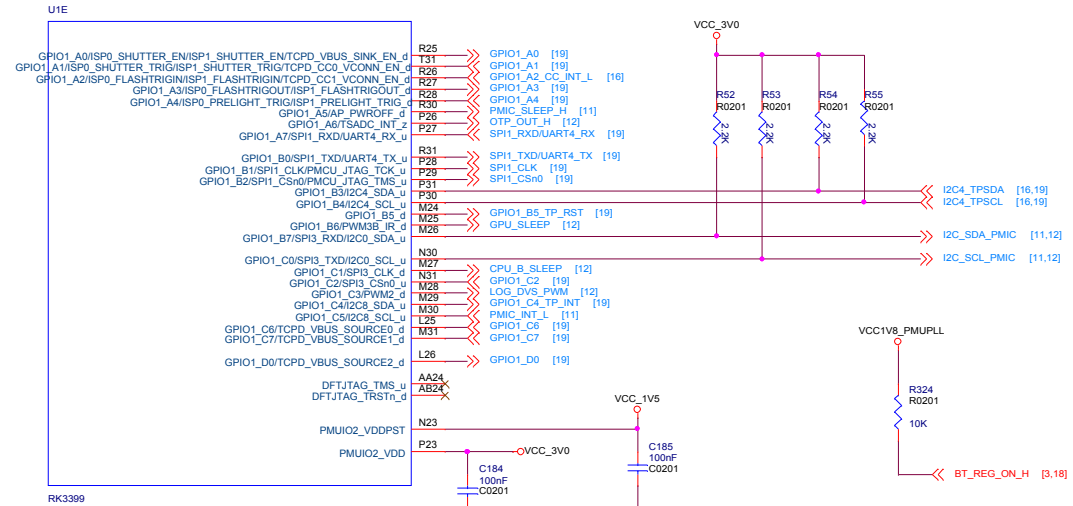
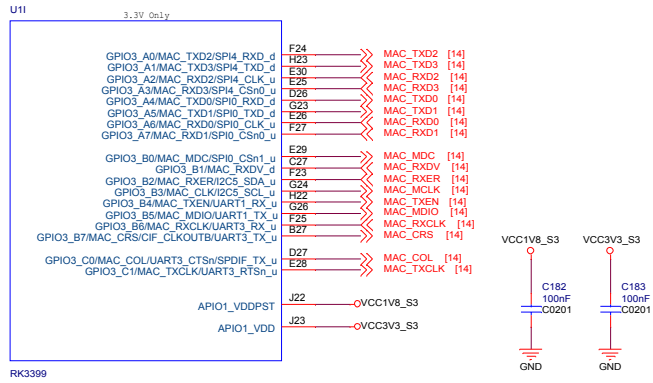

| | |
|-----------|--------------------------------------------------------------------------|
| 1.8V Only | VDDPST=VDDIO=1.8V |
| 3.3V Only | VDDPST=1.8V, VDDIO=3.3V |
| other | 3.0V mode: VDDPST=1.5V, VDDIO=3.0V 1.8V mode: VDDPST=1.8V, VDDIO=1.8V |

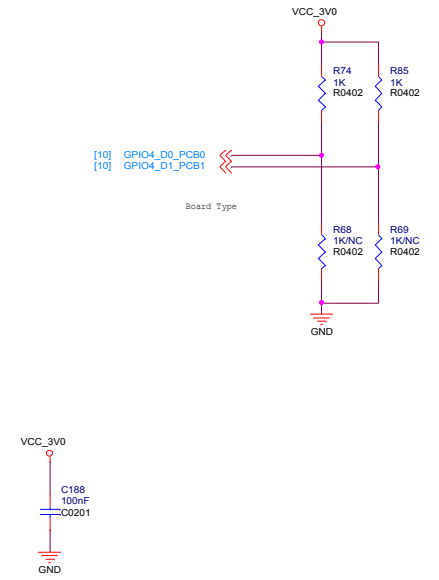
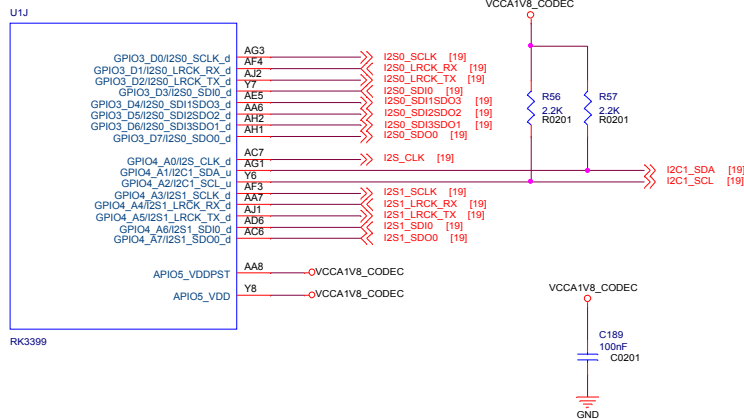
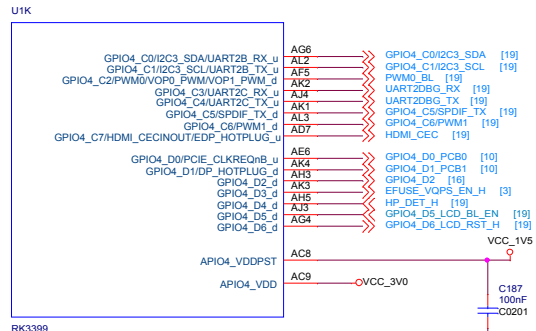
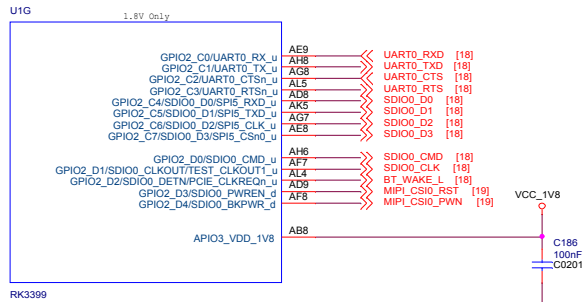

| | | |
|------------|-----------------------------|----------------|
| SOM-RK3399 | | |
| Size | Document Number | Rev |
| Custom | 10.RK3399 RGMII/SDIO/SP/rtc | 1904 |
| Date: | Wednesday, May 22, 2019 | Sheet 10 of 20 |

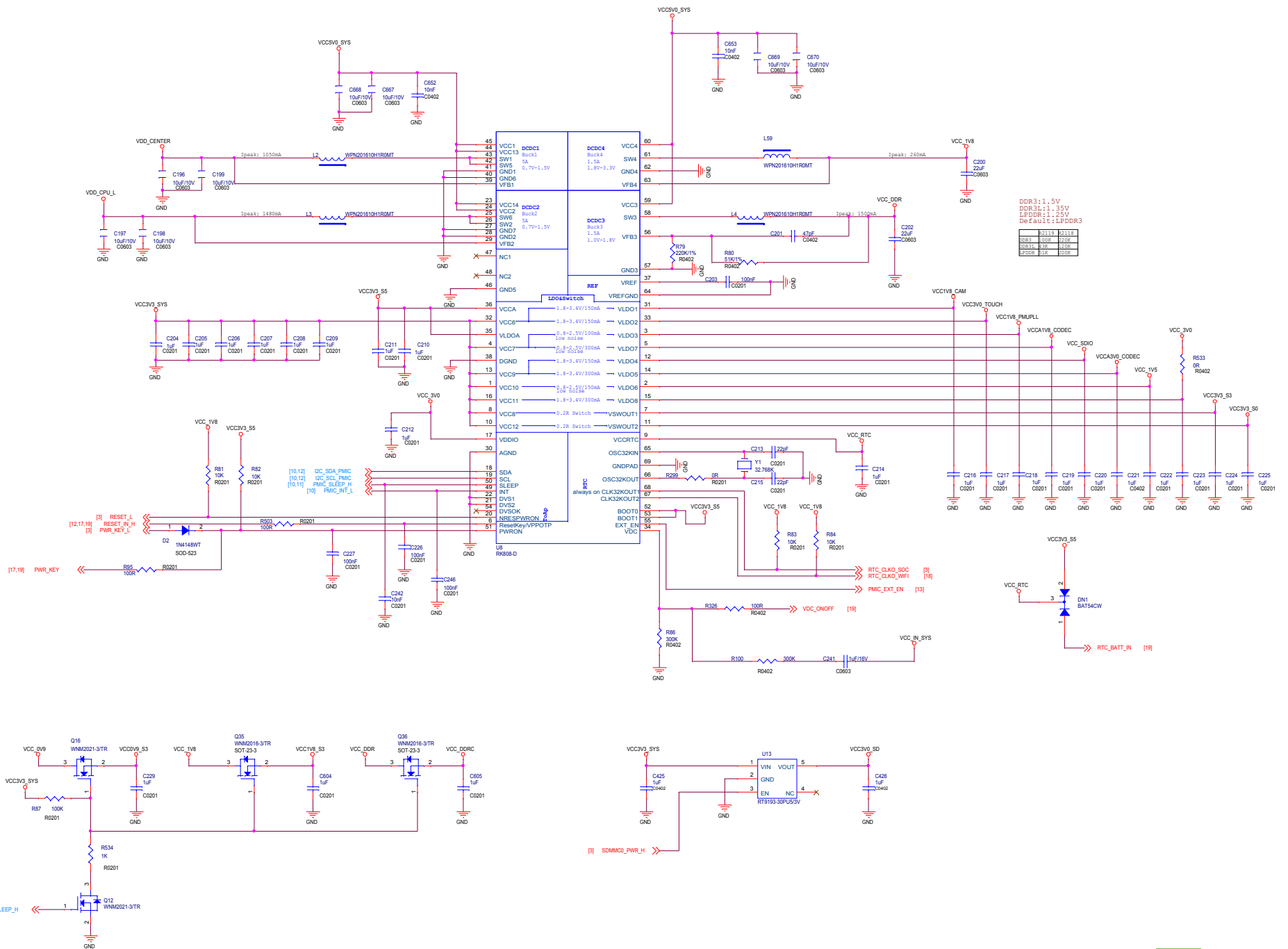

DDR3:1.5V
 DDR3L:1.35V
 LPDDR:1.25V
 Default:LPDDR3

| Q23 | Q24 | Q25 |
|-----|-----|-----|
| Q23 | Q24 | Q25 |
| Q23 | Q24 | Q25 |
| Q23 | Q24 | Q25 |



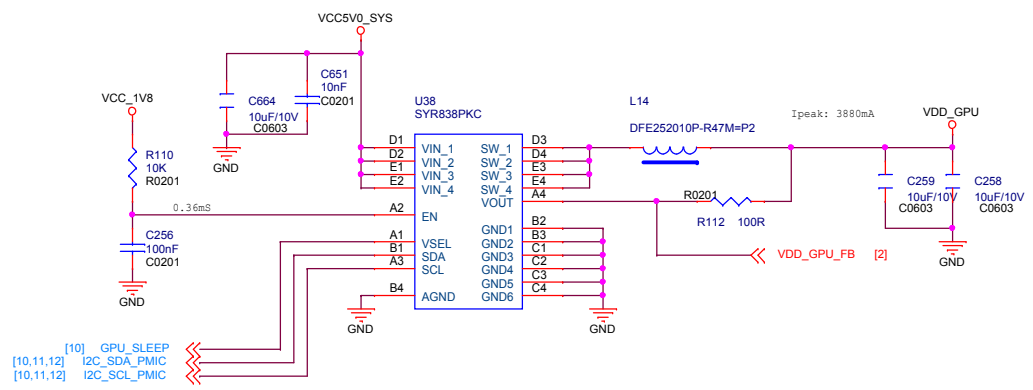

Over-temperature Protection

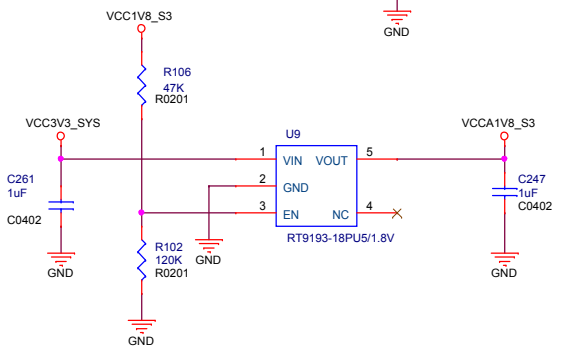
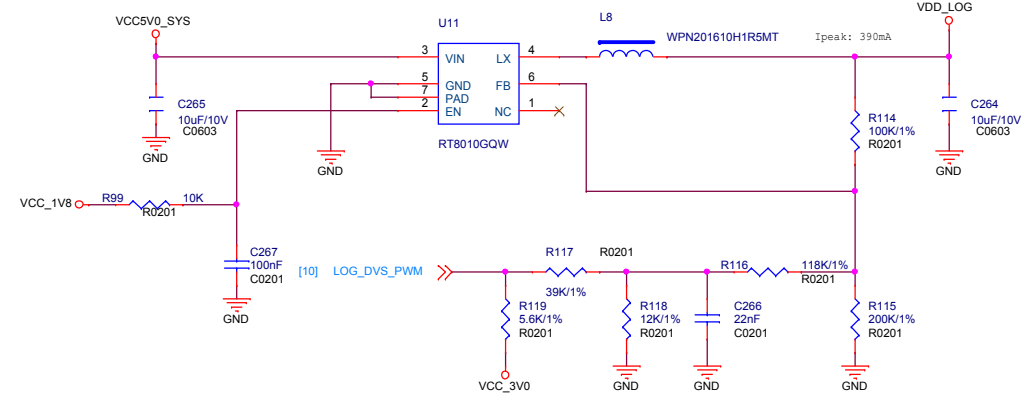
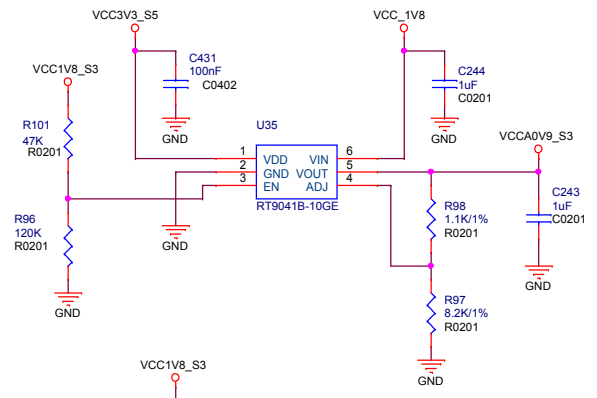
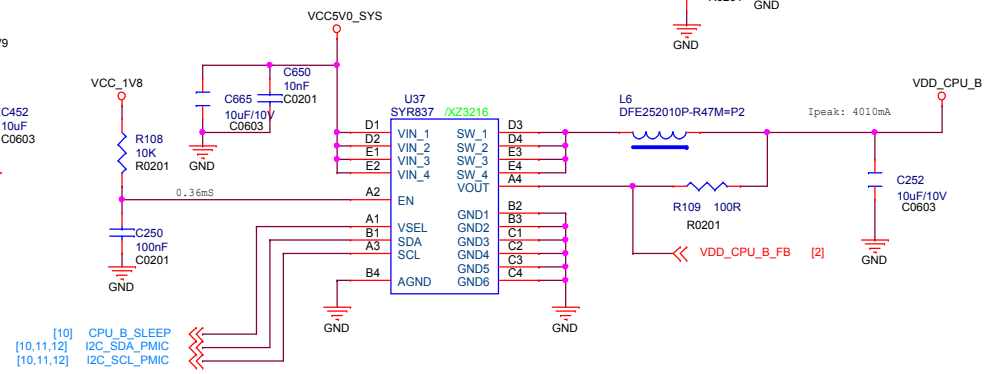
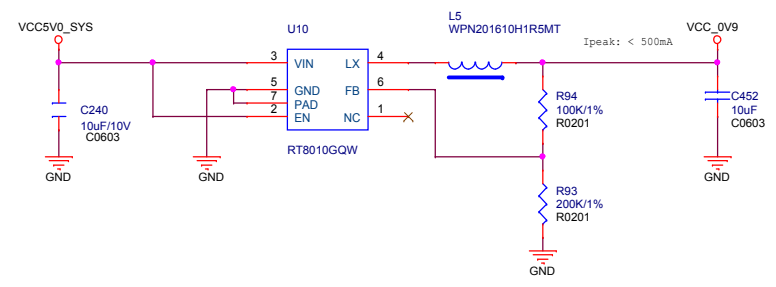
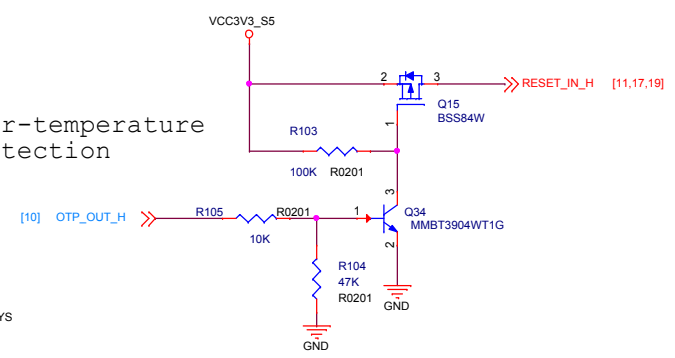

| | | |
|------------|------------------------------------------|----------------|
| SOM-RK3399 | | |
| Size A3 | Document Number 12.Power2-CPU/GPU/etc | Rev 1904 |
| Date: | Wednesday, May 22, 2019 | Sheet 12 of 20 |

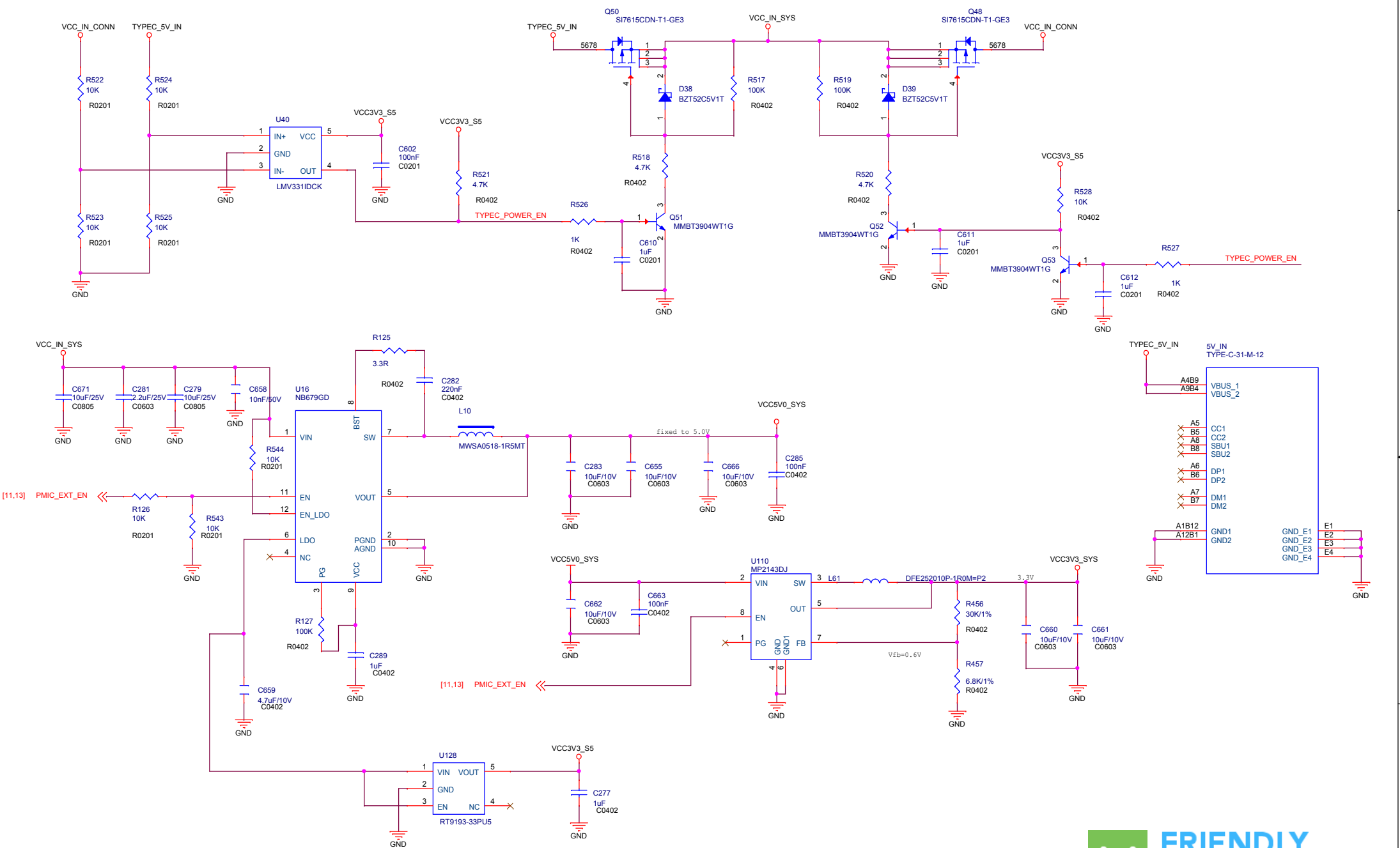

| | | |
|-------------------------------|-----------------------------------|----------|
| SOM-RK3399 | | |
| Size A3 | Document Number 13.Power3-3.3V/5V | Rev 1904 |
| Date: Wednesday, May 22, 2019 | Sheet 13 | of 20 |

10/100/1000M Ethernet

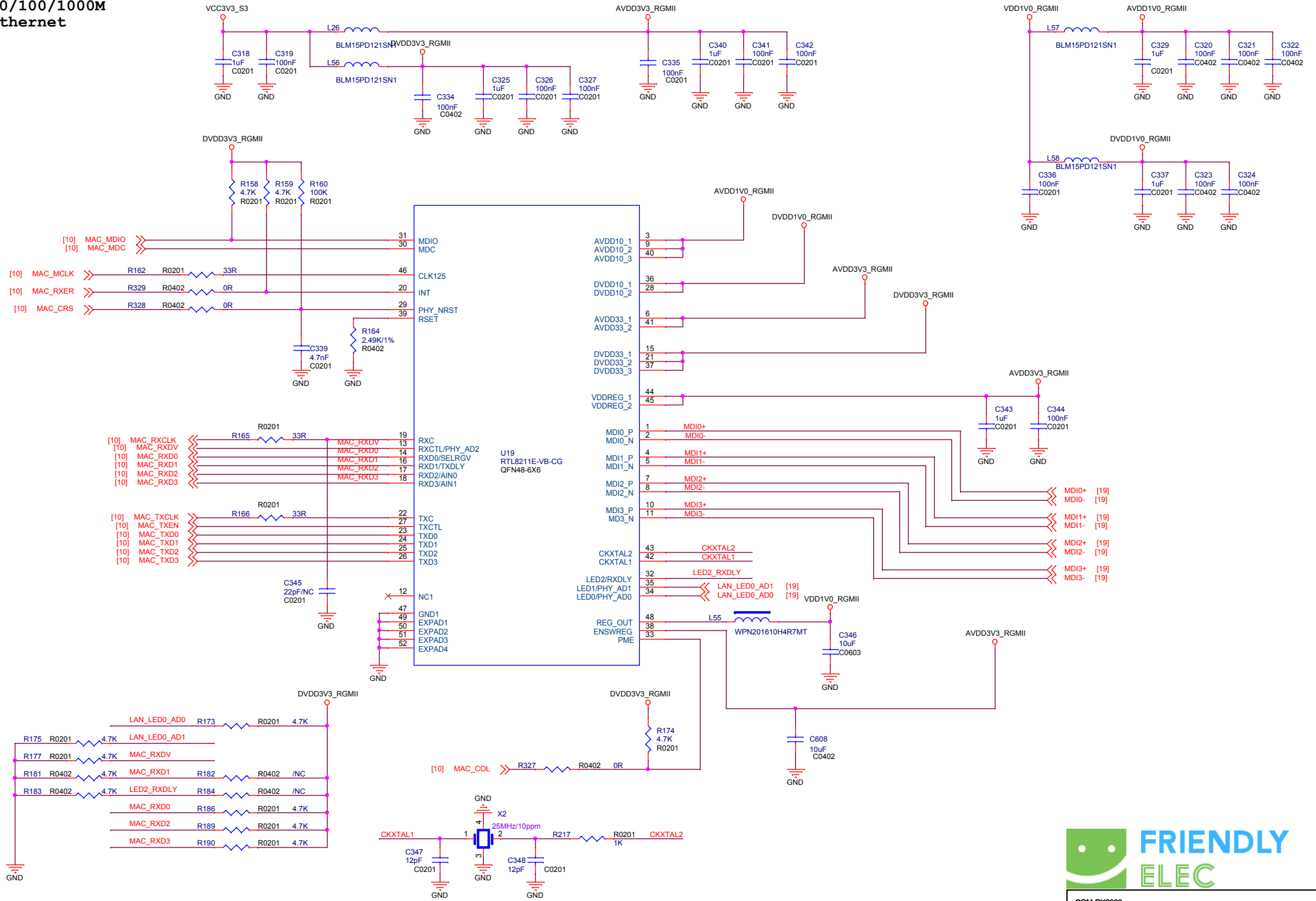

| | | |
|------------|-------------------------|----------------|
| SOM-RK3399 | | |
| Size | Document Number | Rev |
| A3 | 14.RGMII-10/100/1000M | 1904 |
| Date: | Wednesday, May 22, 2019 | Sheet 14 of 20 |

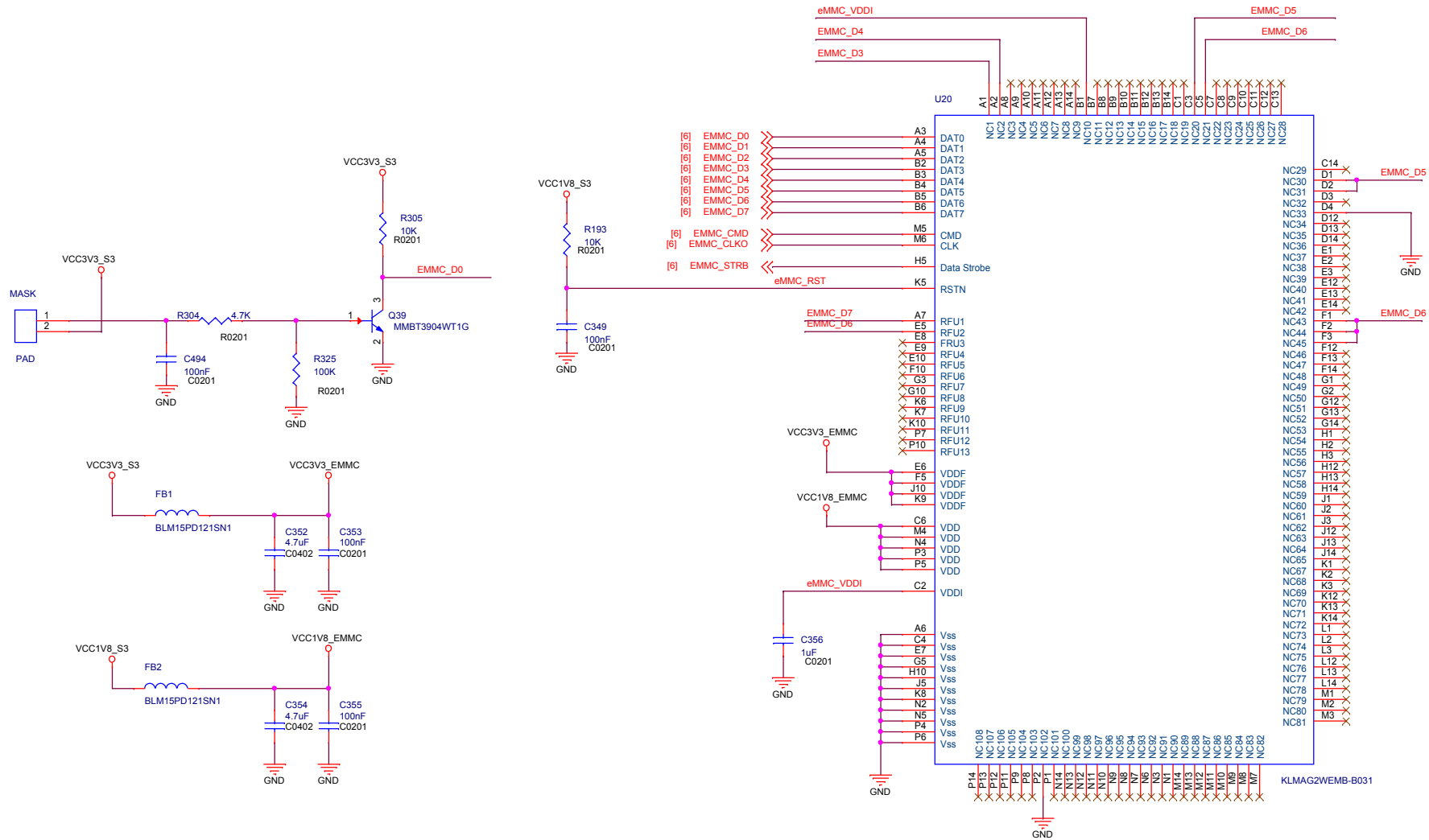

USB Type-C

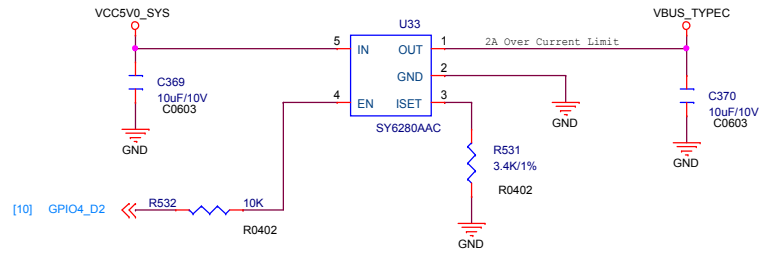
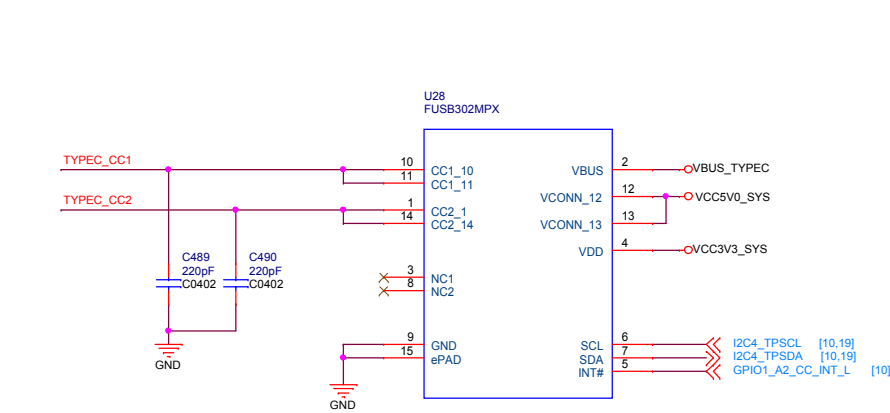
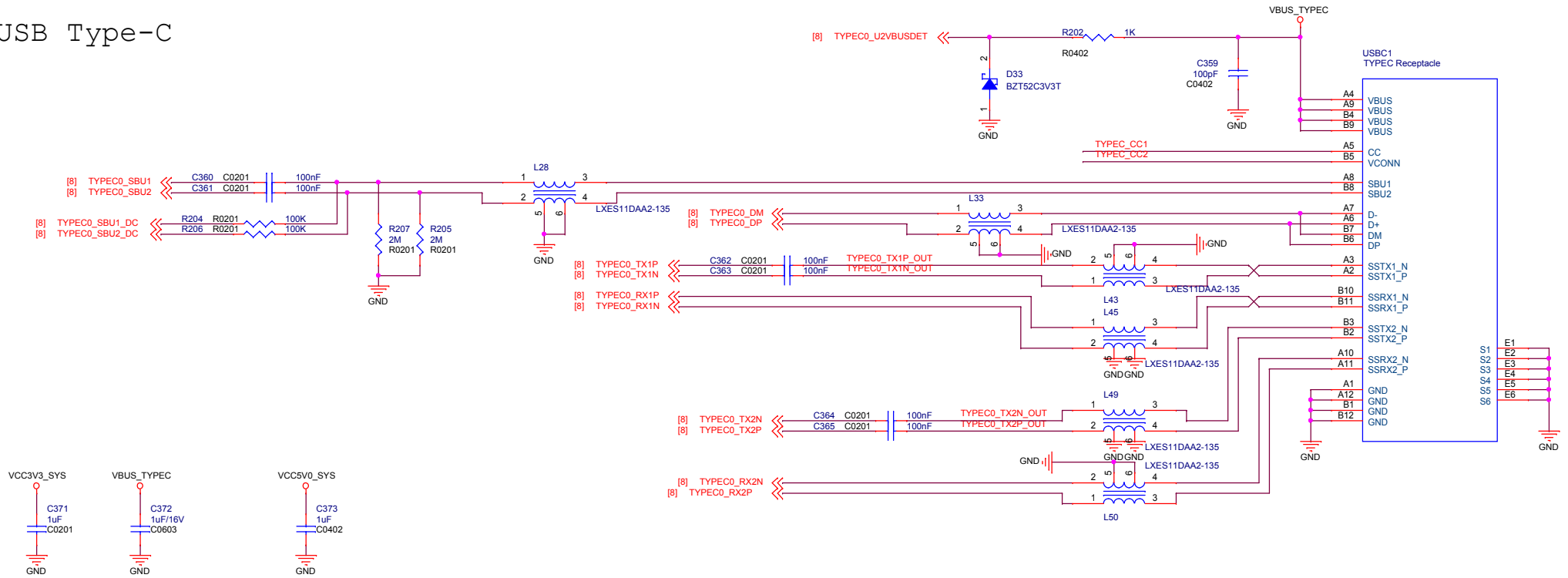

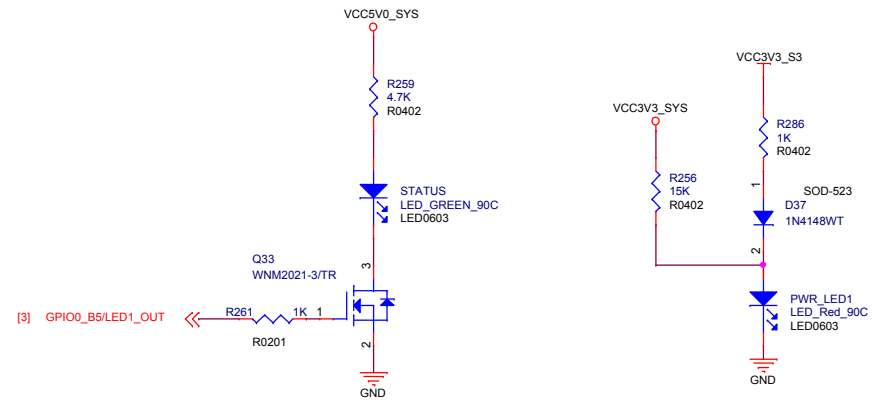
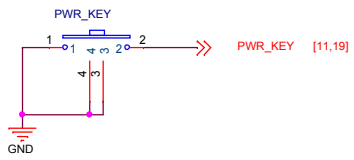
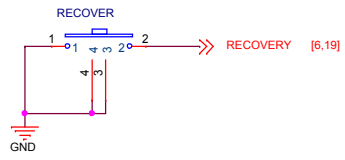
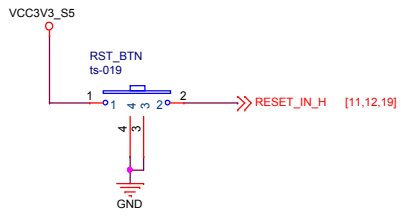

WIFI/WIFI ac/BT MODULE

