

NanoPi NEO Core2

Revision
1707 , First Release



NanoPi NEO Core2		
Size A3	Document Number Title	Rev 1707
Date:	Monday, November 27, 2017	Sheet 1 of 11

BLOCK

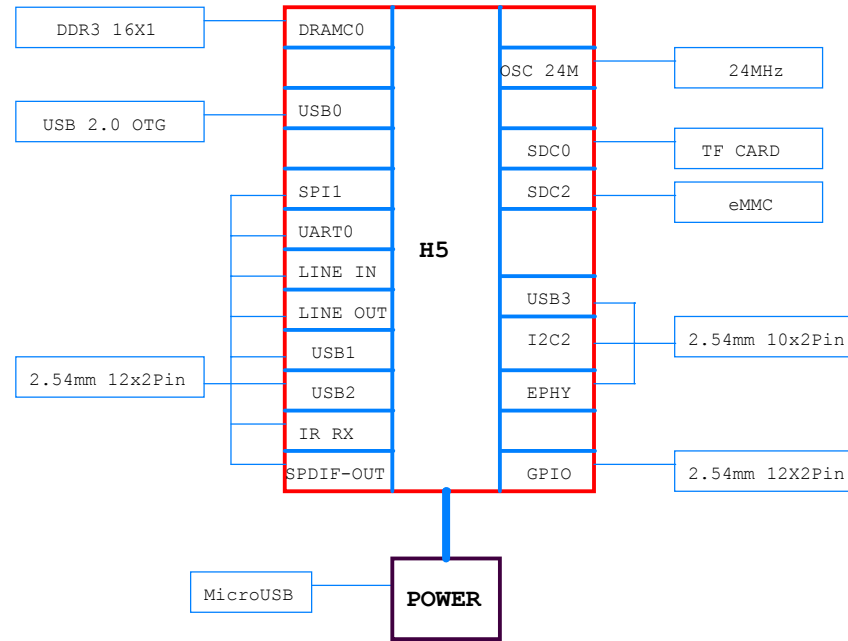

POWER TREE

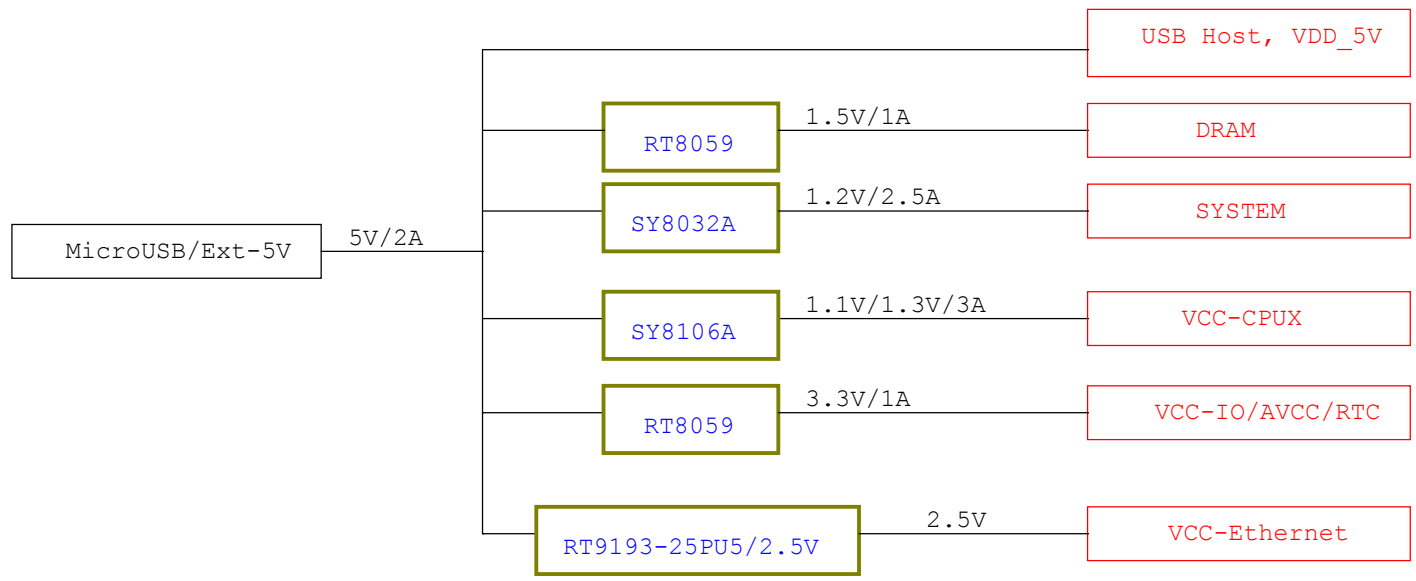

DDR3 16x1

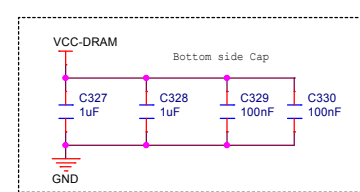
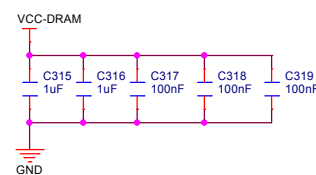
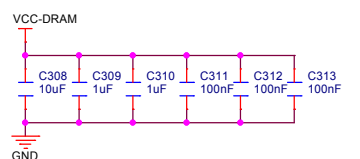
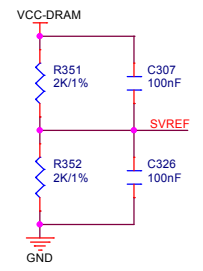
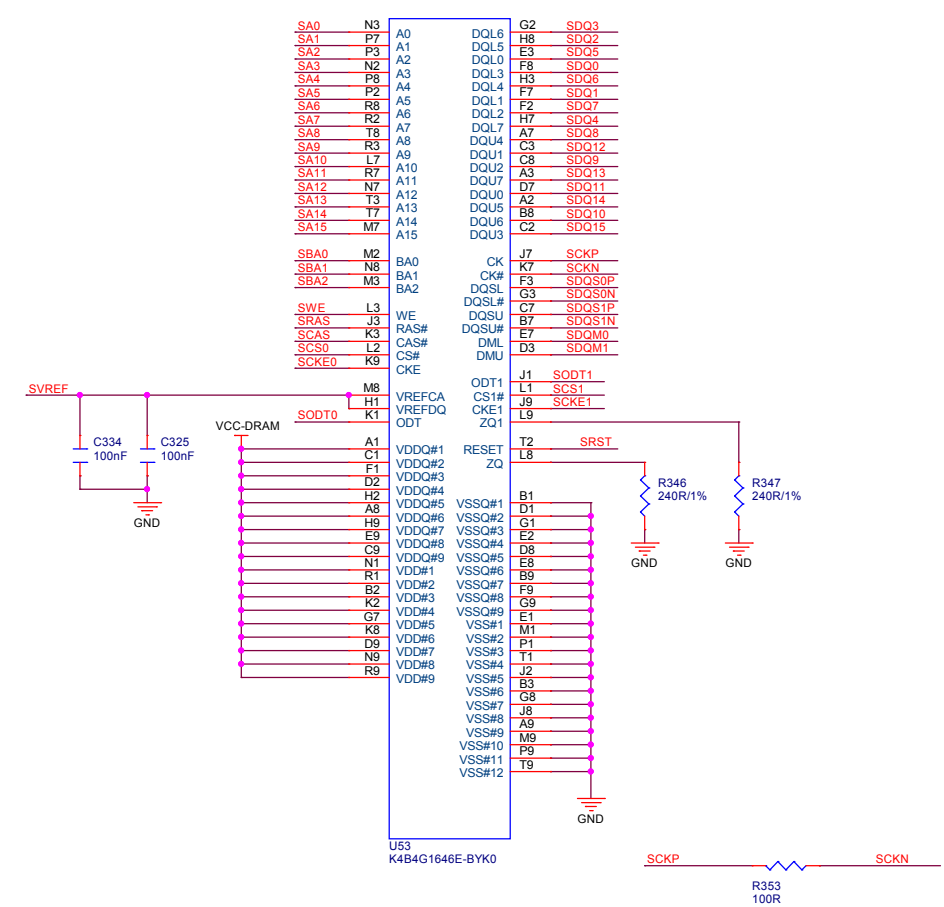
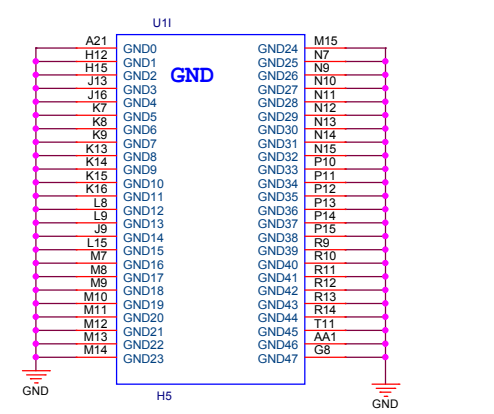
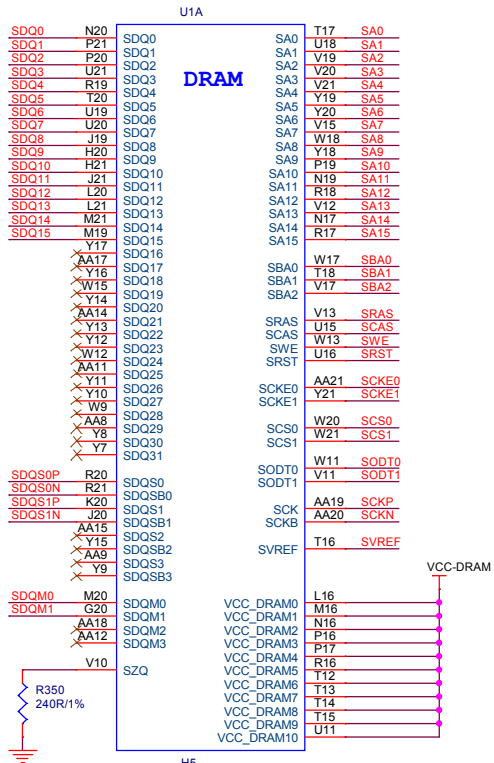

CPU 01

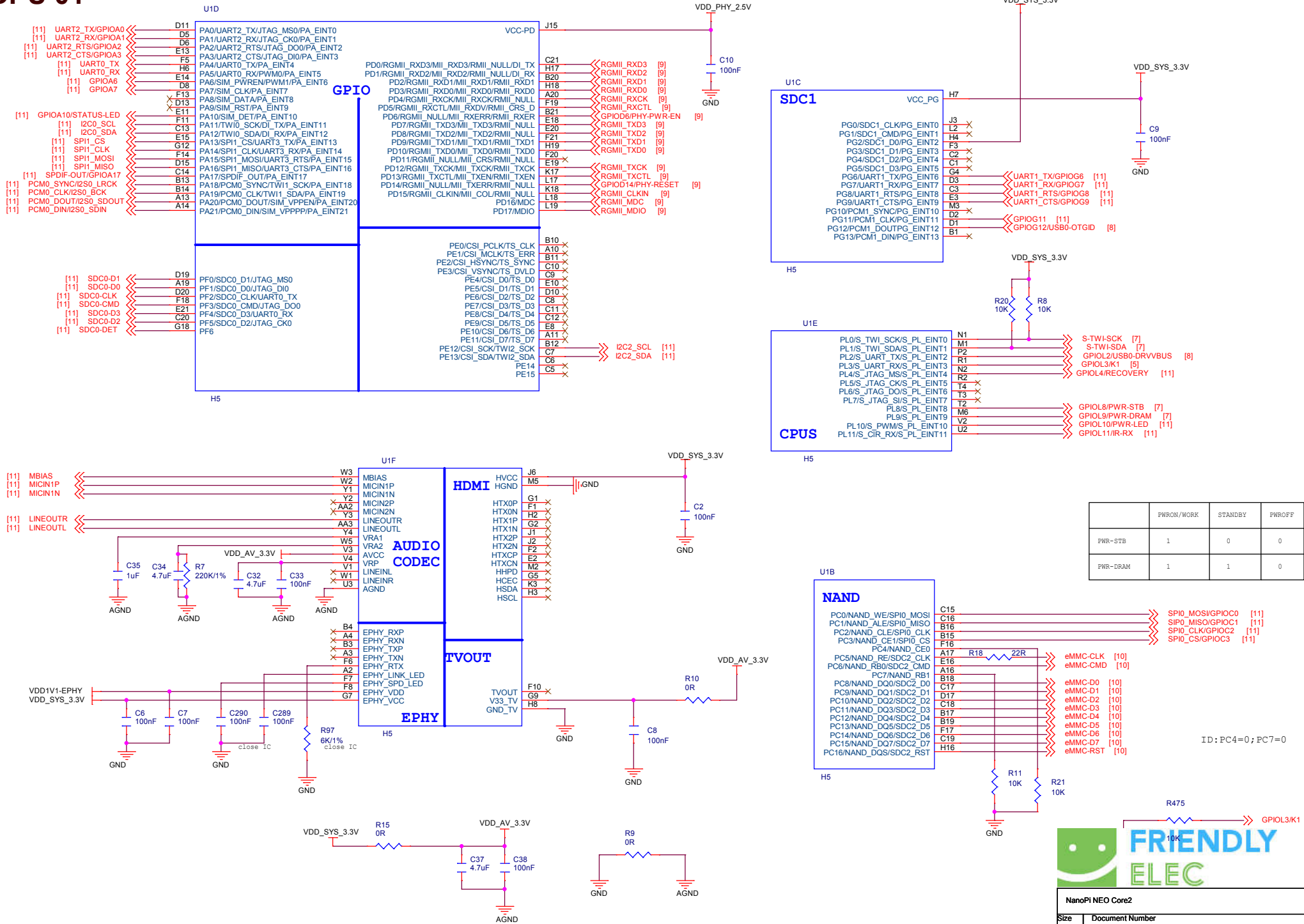

	PWRON/WORK	STANDBY	PWROFF
PWR-STB	1	0	0
PWR-DRAM	1	1	0



CPU 02

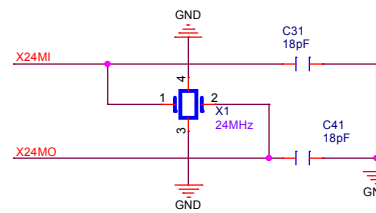
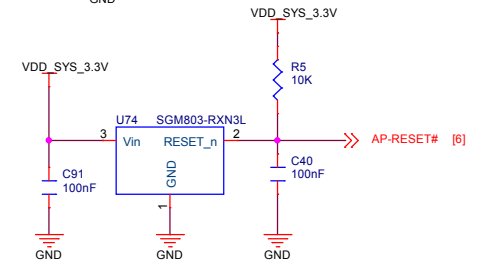
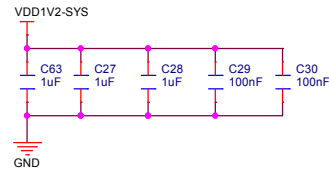
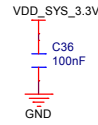
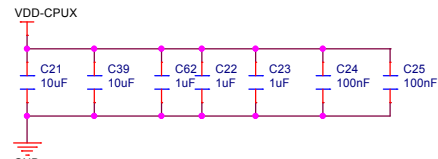
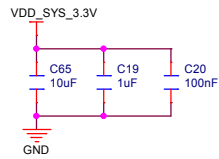
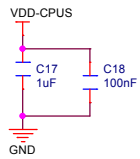
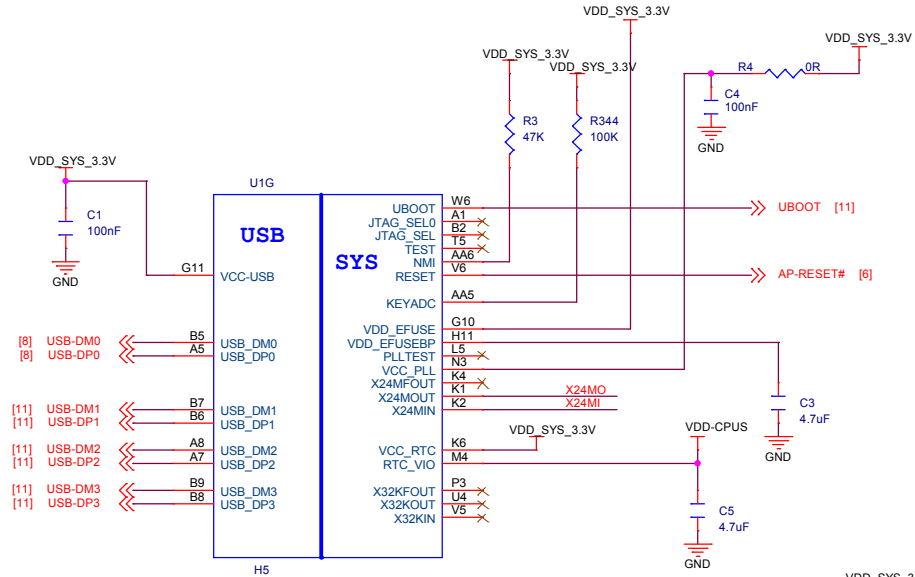
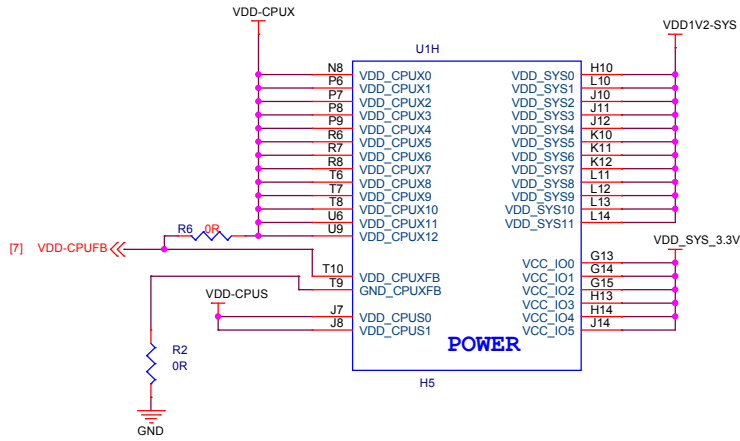

POWER 01

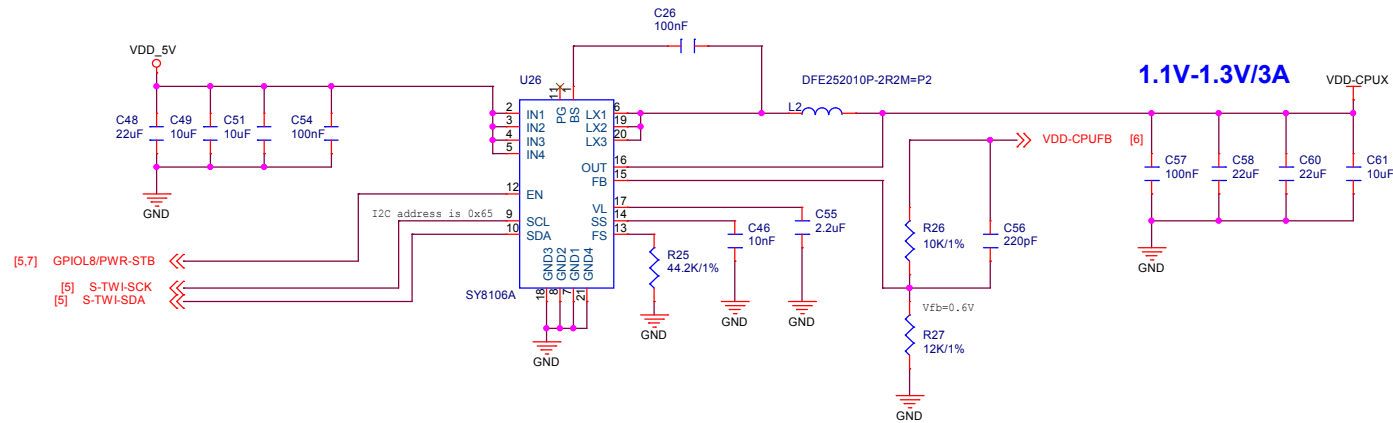
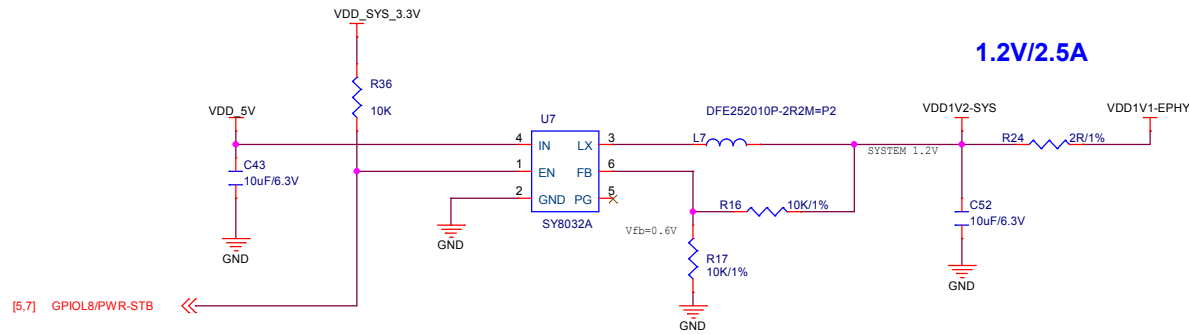
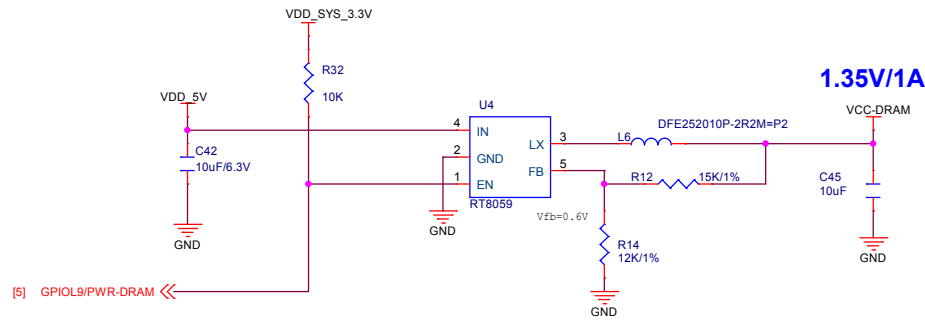

POWER 02

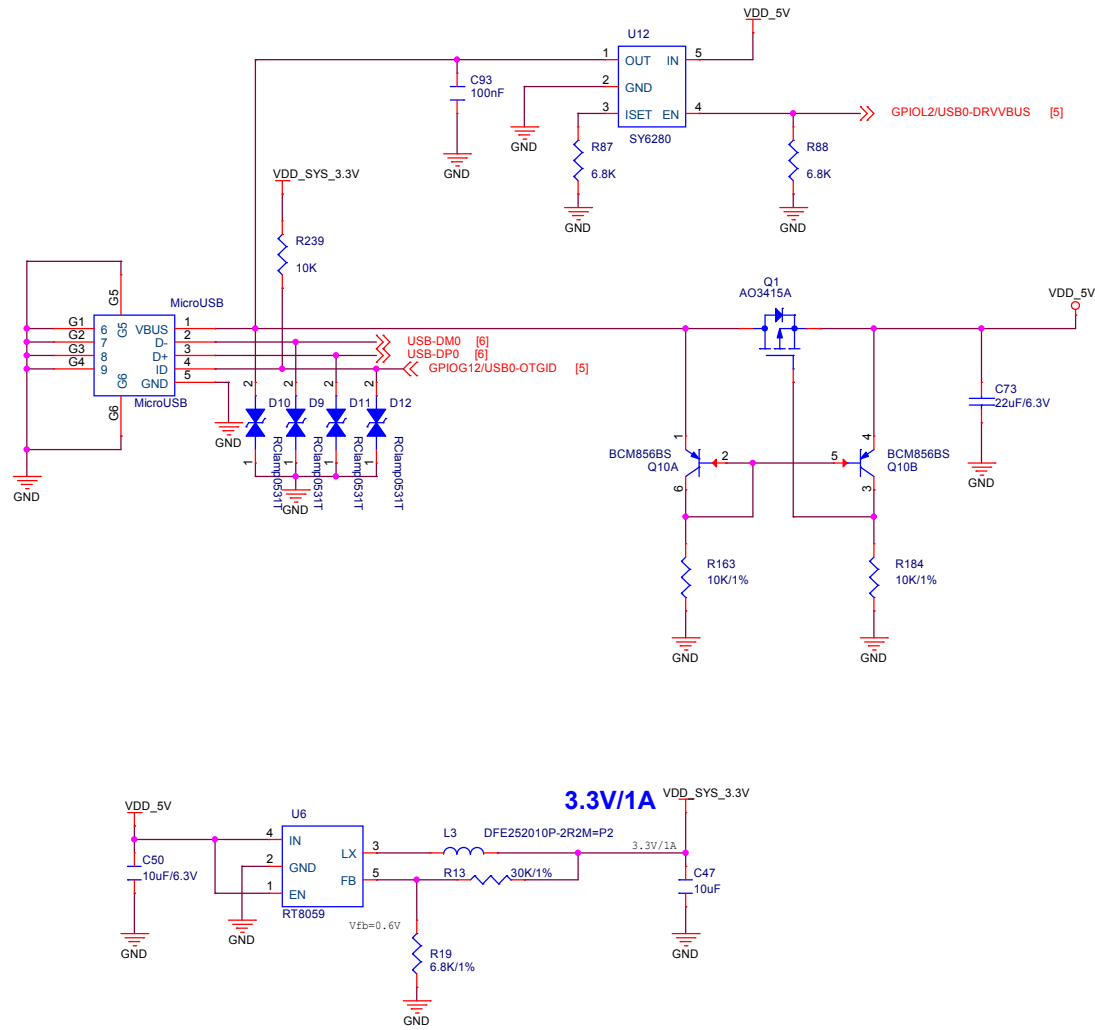

10/100/1000M Ethernet

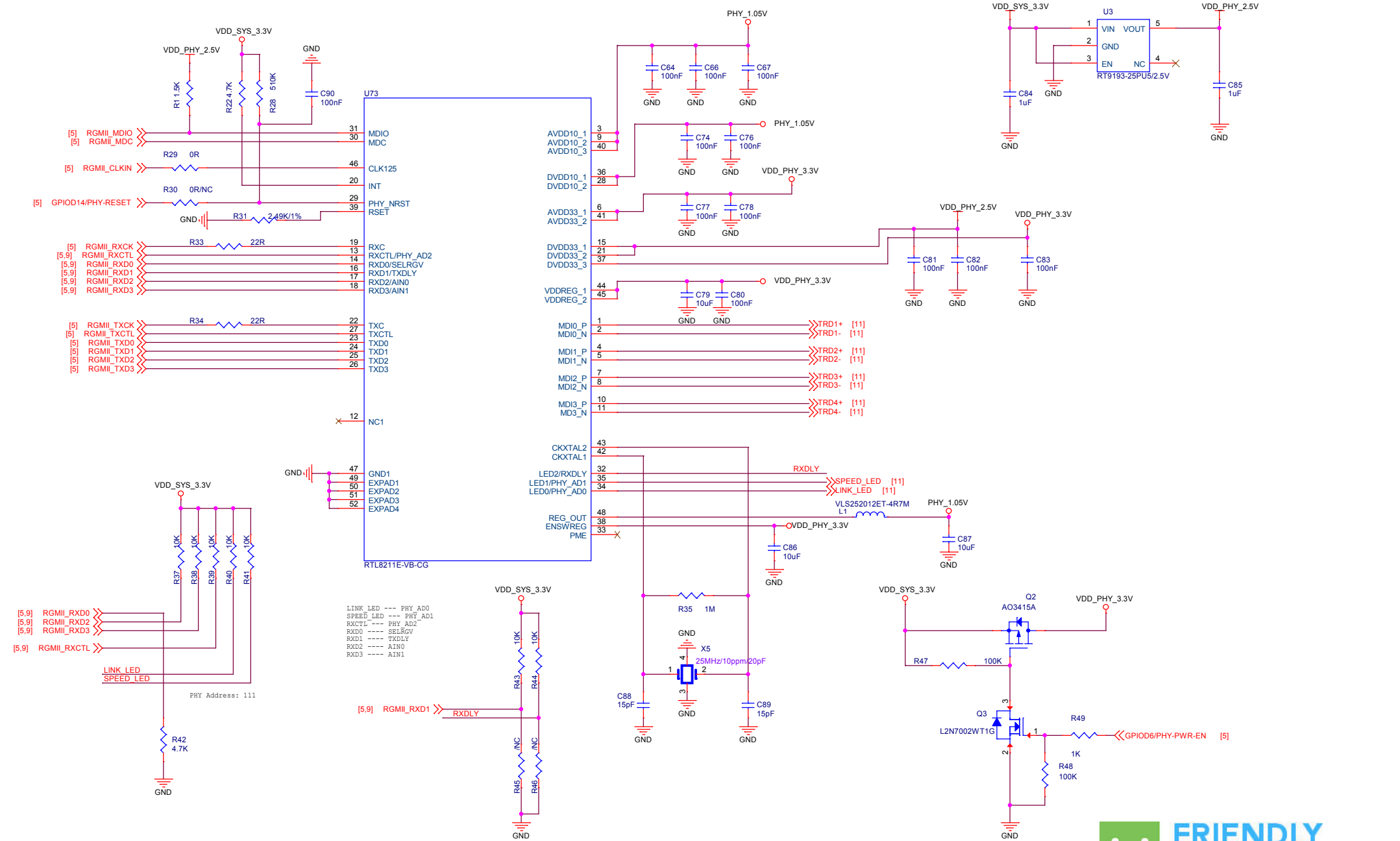

eMMC

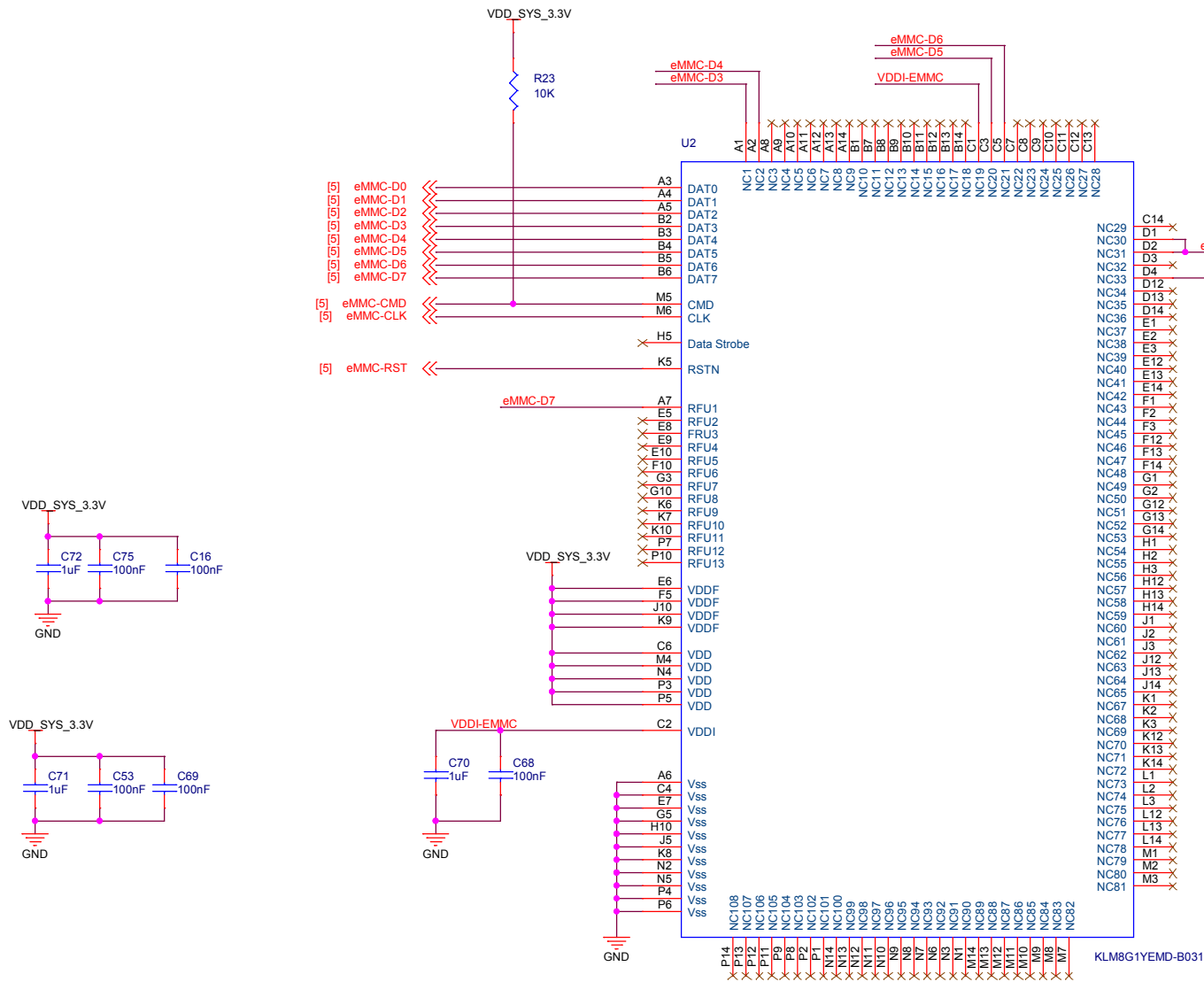

NanoPi NEO Core2		
Size B	Document Number eMMC	Rev 1707
Date:	Monday, November 27, 2017	Sheet 10 of 11

GPIO,Card,LEDs

