

Smart4418/6818

FRIENDLYARM

Smart4418/6818		
Size A3	Document Number 01.Title	Rev 1711
Date:	Thursday, July 26, 2018	Sheet 1 of 14

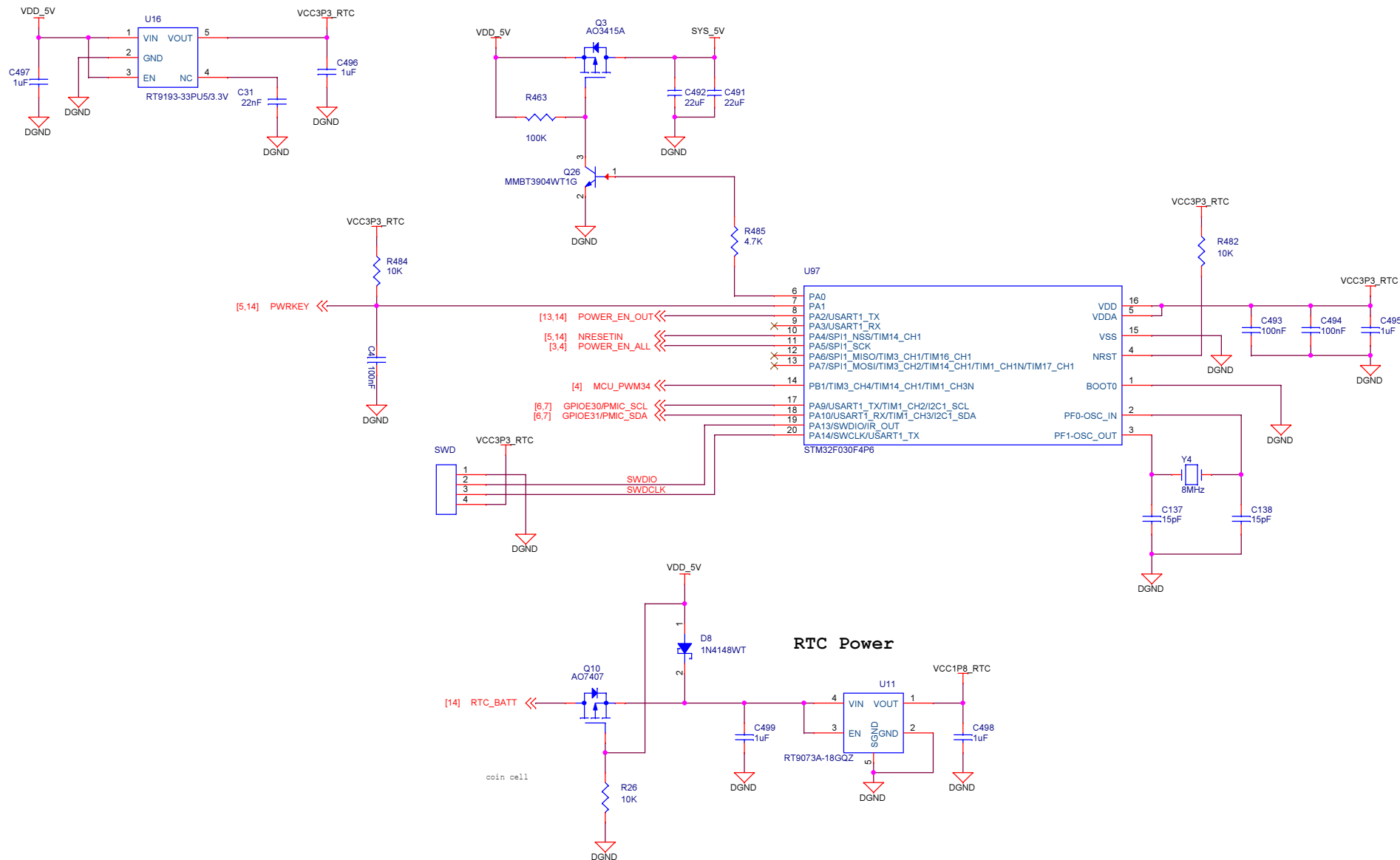

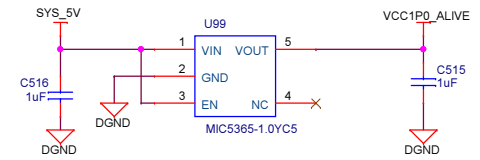
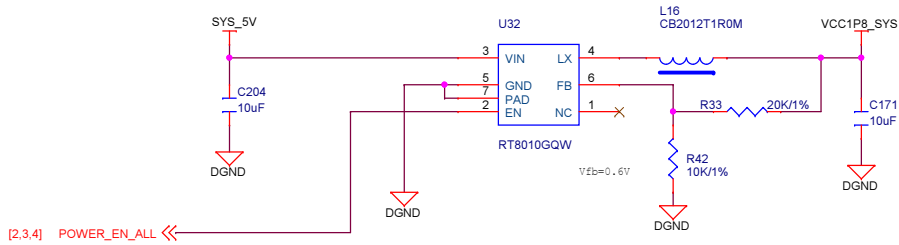
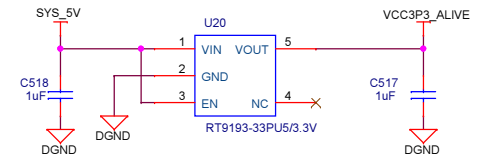
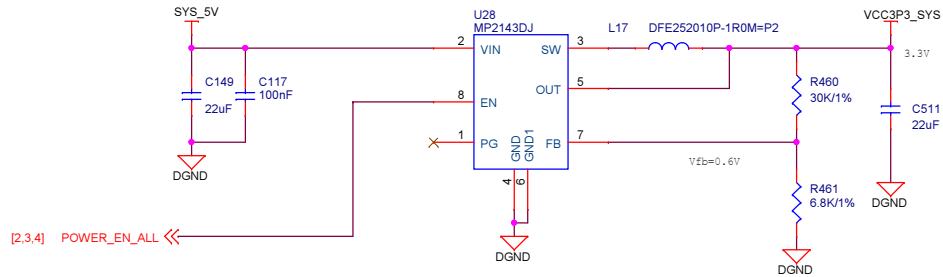
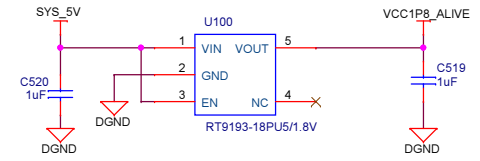
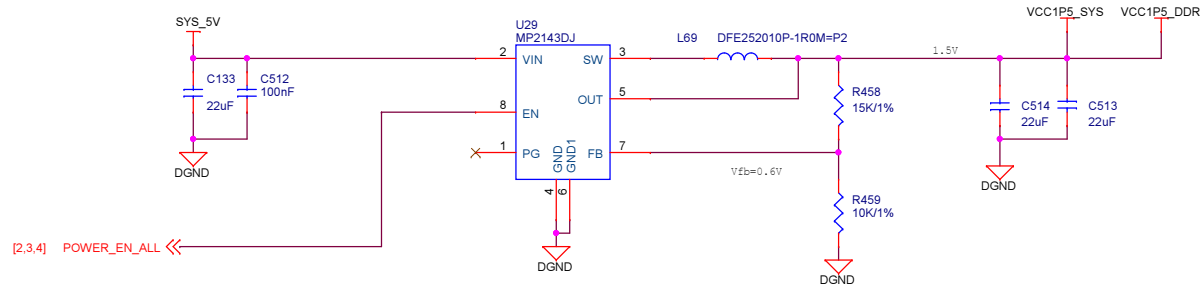

VDD_ARM

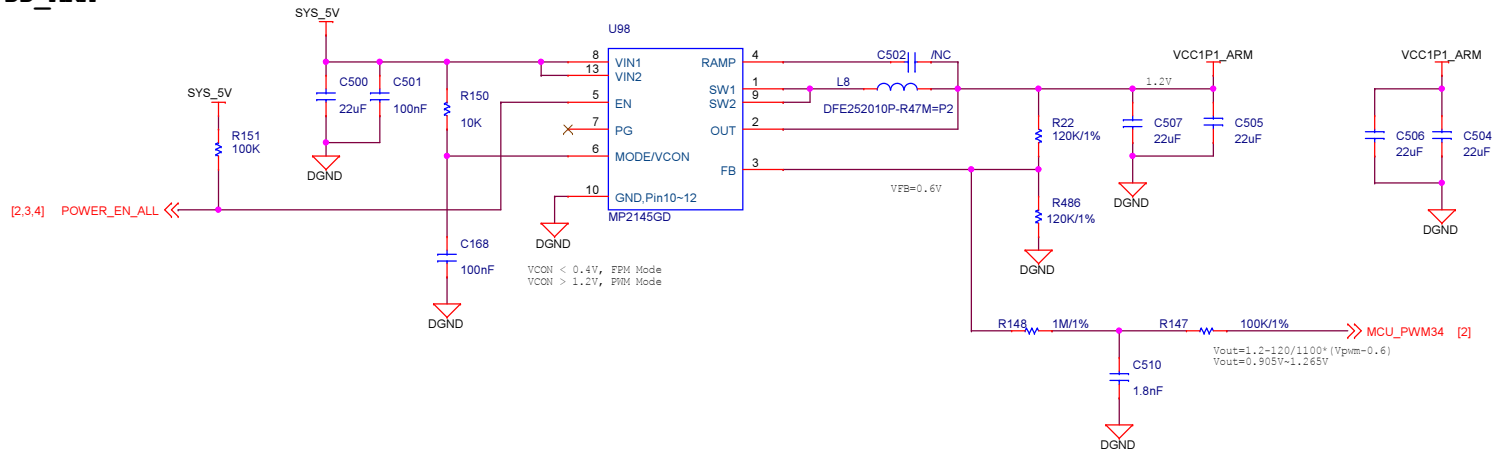

VDD_CORE

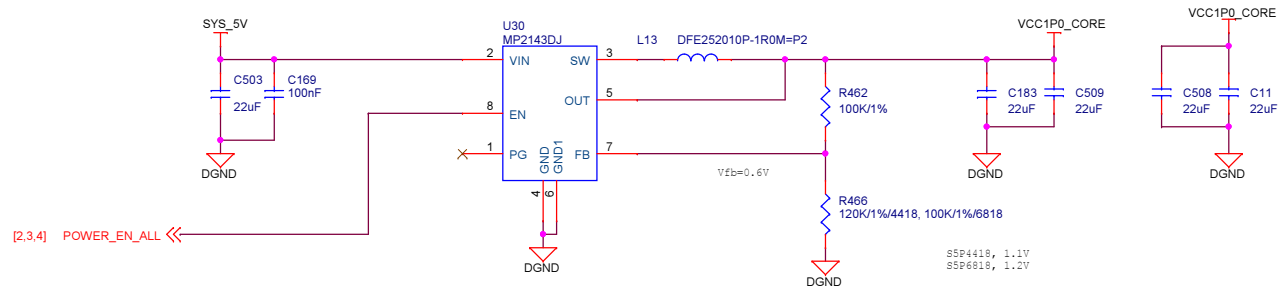

System Reset, Clocks

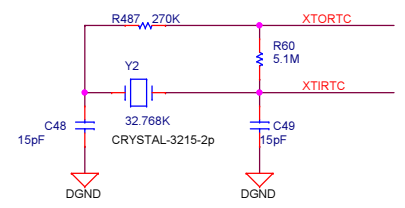
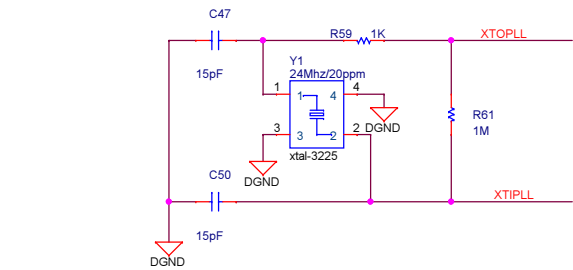
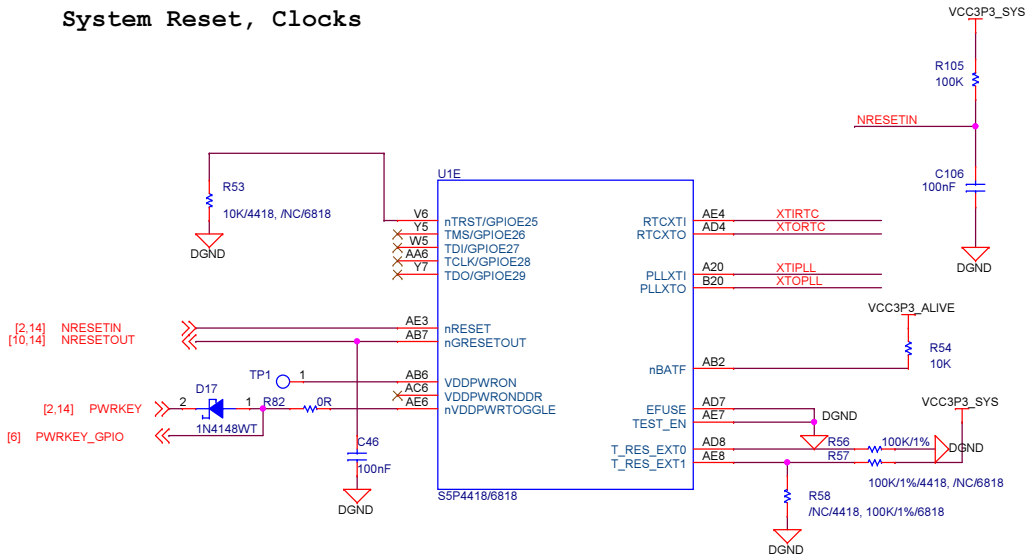

Boot Mode Config

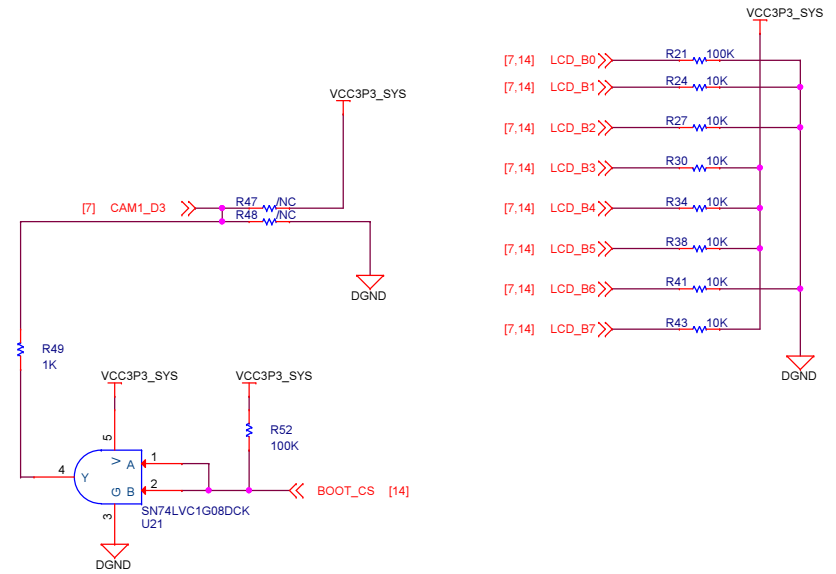

Boot media port select

	CH0	CH1	CH2
SD3	LOW	HIGH	LOW
CAM1_D3	LOW	LOW	HIGH

PCB Version

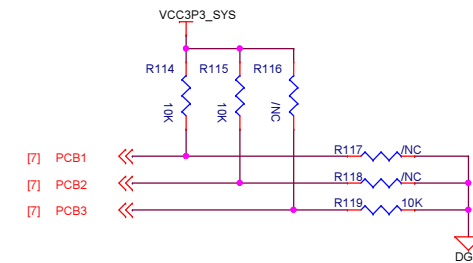

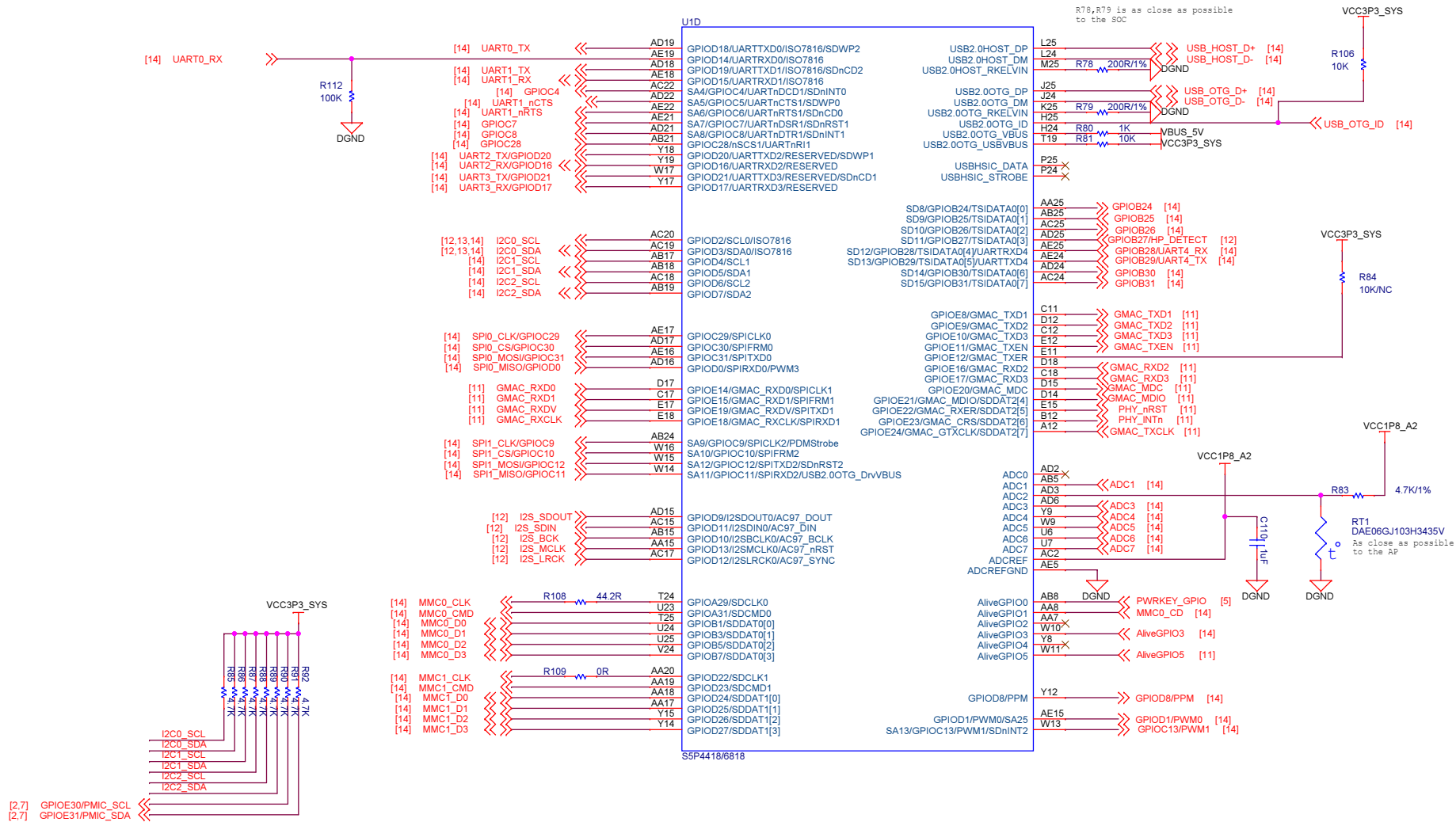

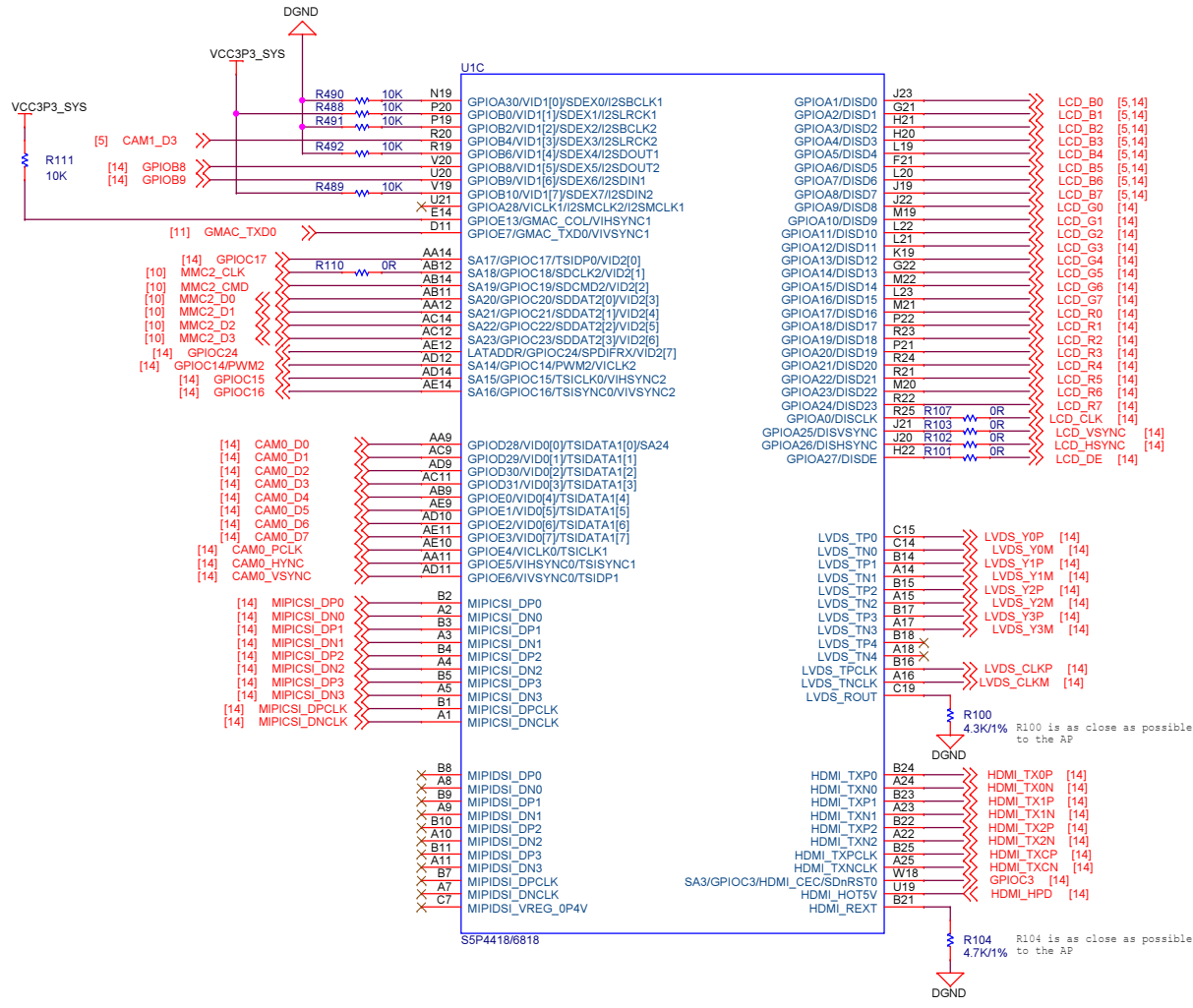

Reserved Function

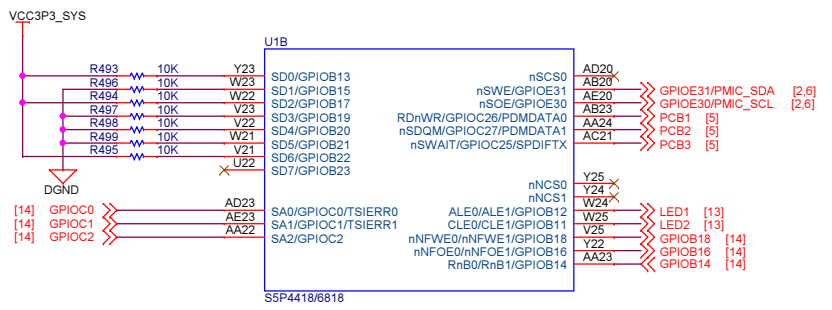
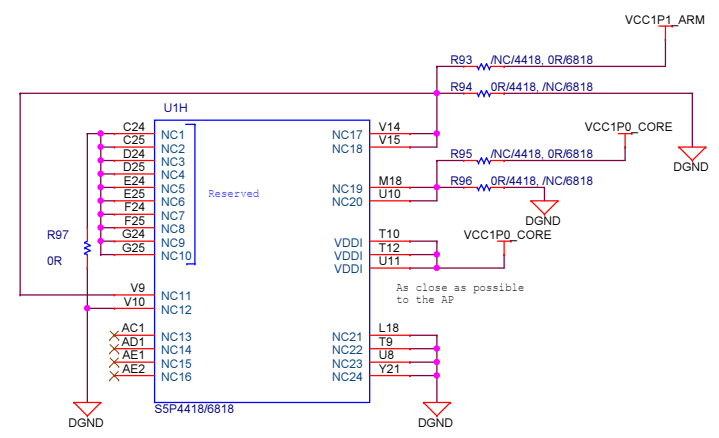

Smart4418/6818		
Size A3	Document Number 07_AP_VIP&Display	Rev 1711
Date: Thursday, July 26, 2018	Sheet 7	of 14

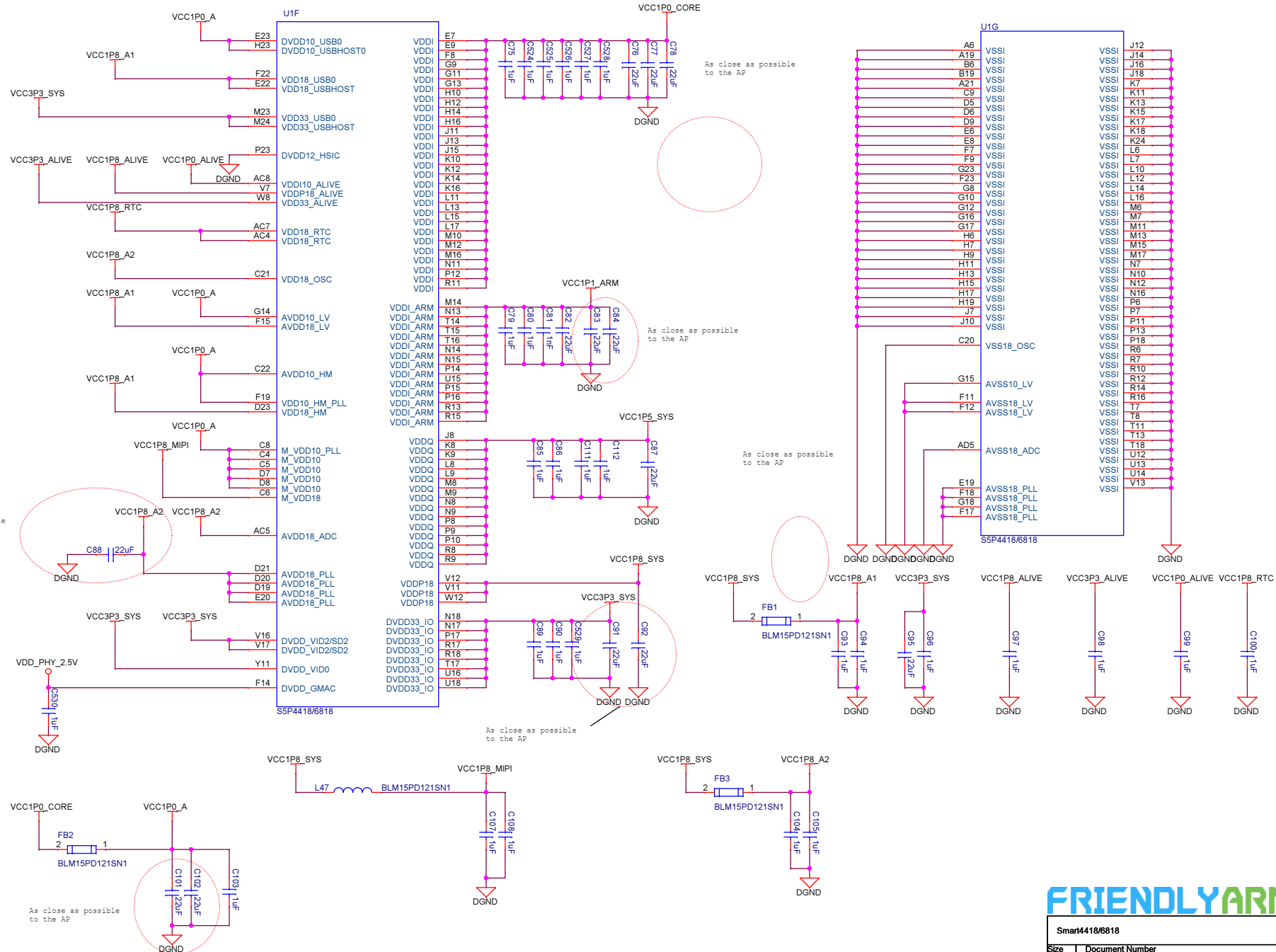

Smart4418/6818		
Size A3	Document Number 08.AP Power	Rev 1711
Date Thursday, July 26, 2018	Sheet 8	of 14

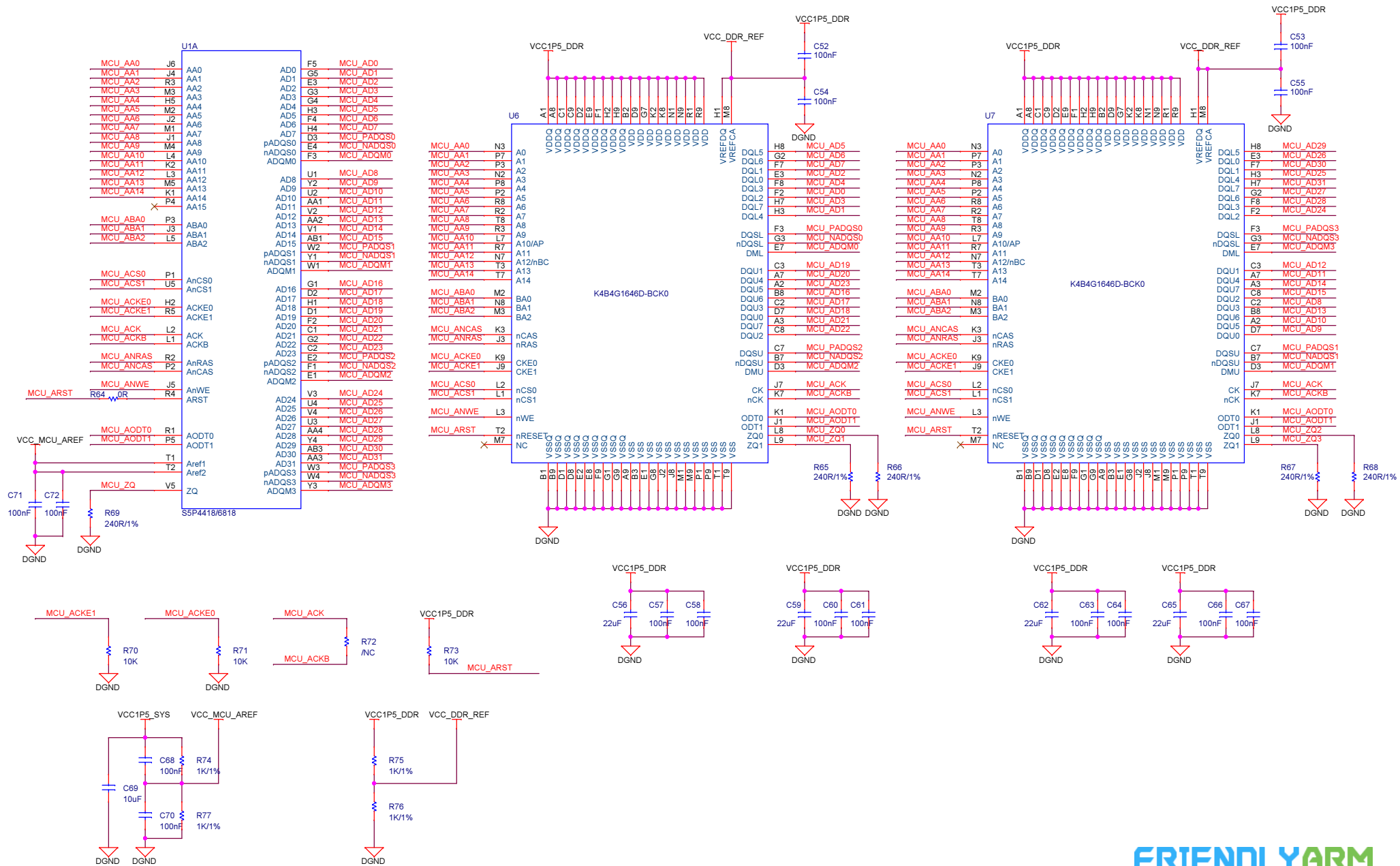

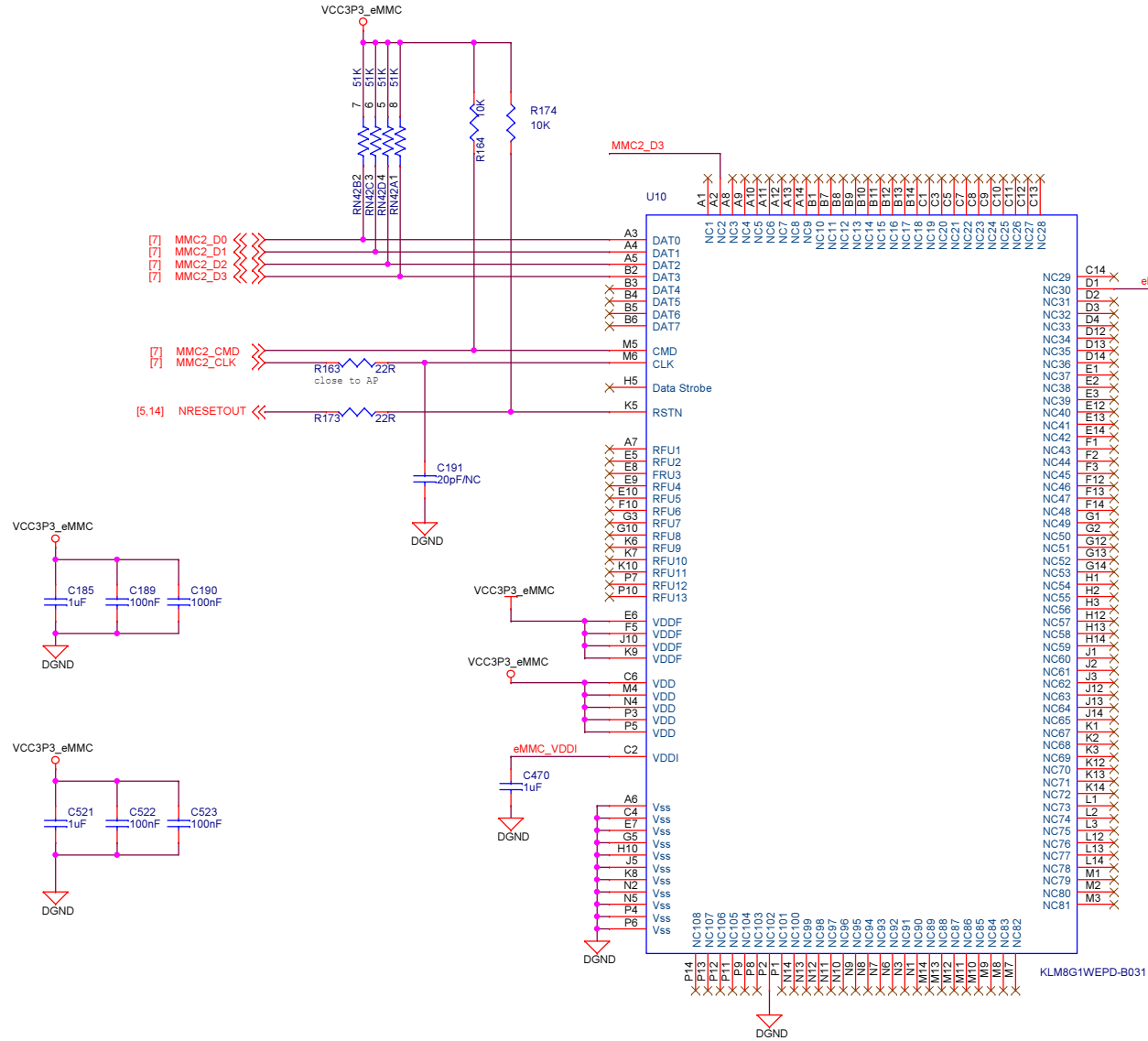
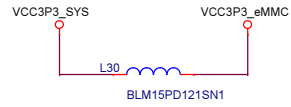

Smart4418/6818		
Size A3	Document Number 10.eMMC	Rev 1711
Date	Thursday, July 26, 2018	Sheet 10 of 14

10/100/1000M Ethernet

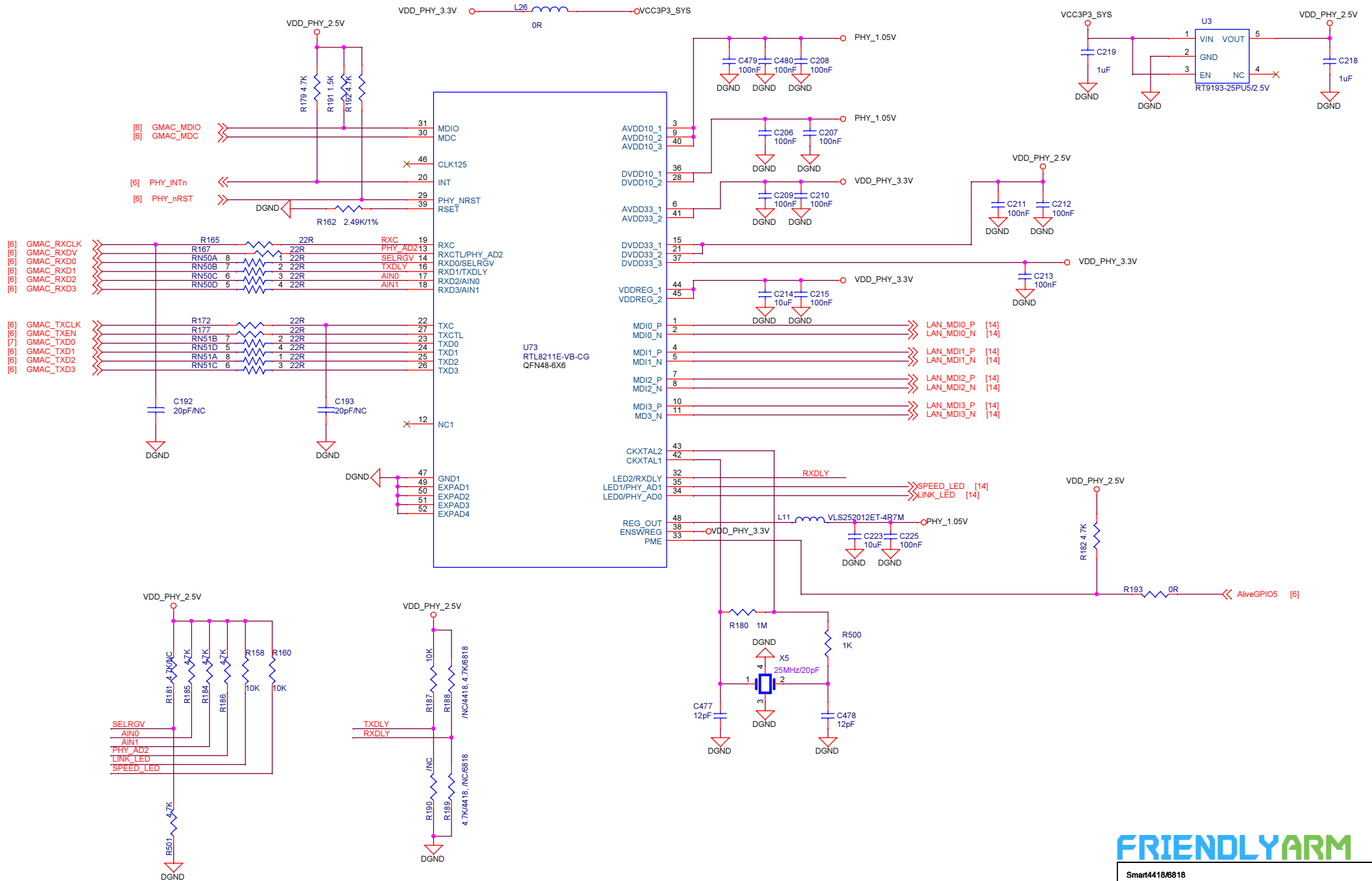

Smart4418/6818		
Size A3	Document Number 11.LAN PHY	Rev 1711
Date: Thursday, July 26, 2018	Sheet 11	of 14

Audio

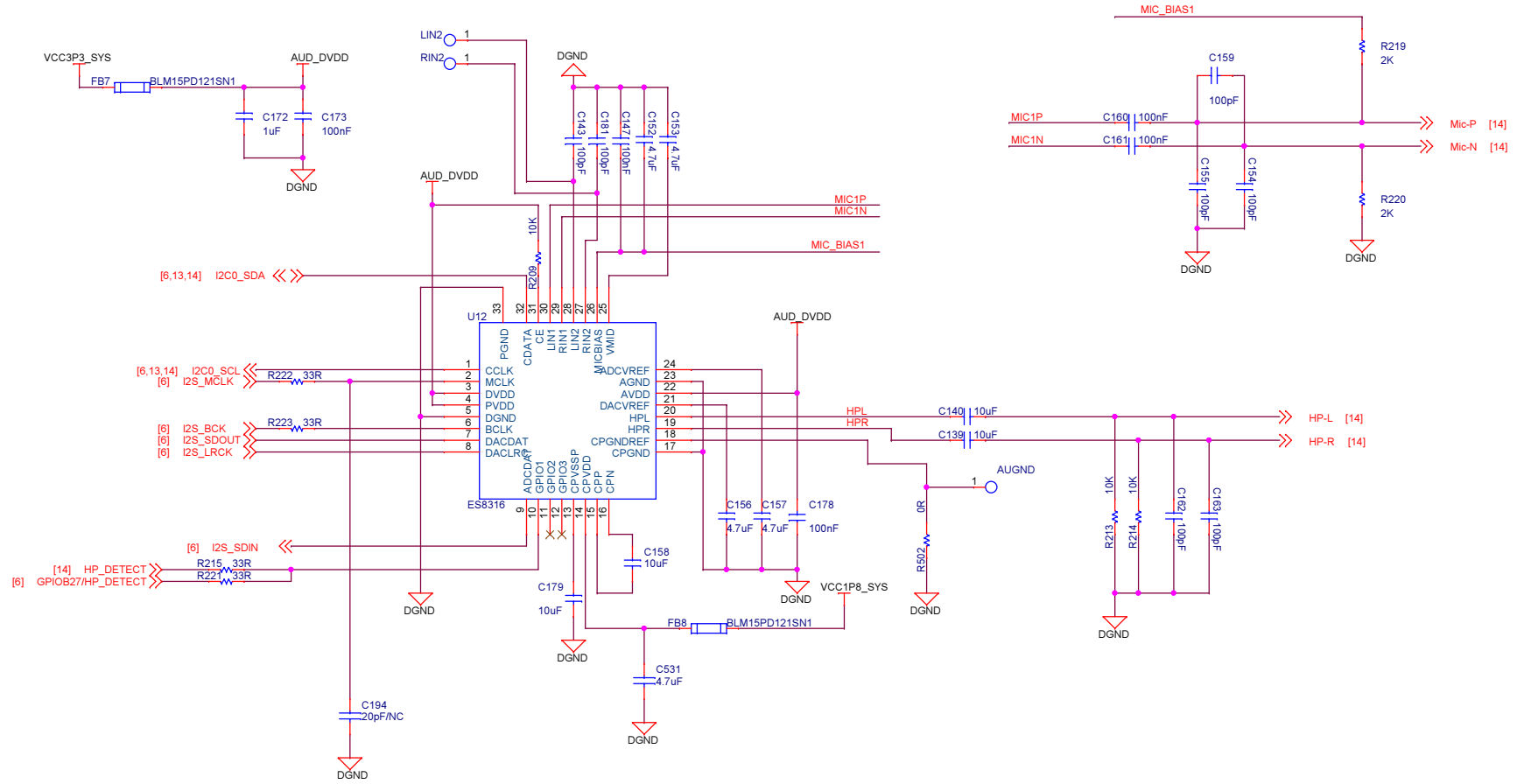

FRIENDLYARM

Smart4418		
Size	Document Number	Rev
A3	Smart4418/6818	1711
Date:	Thursday, July 26, 2018	Sheet 12 of 14

CryptoAuthentication

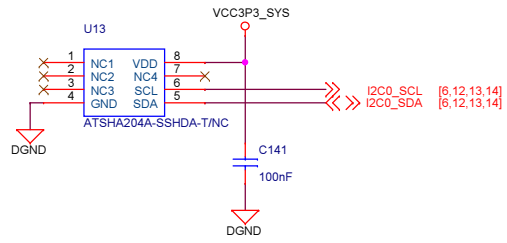

EEPROM with MAC Address

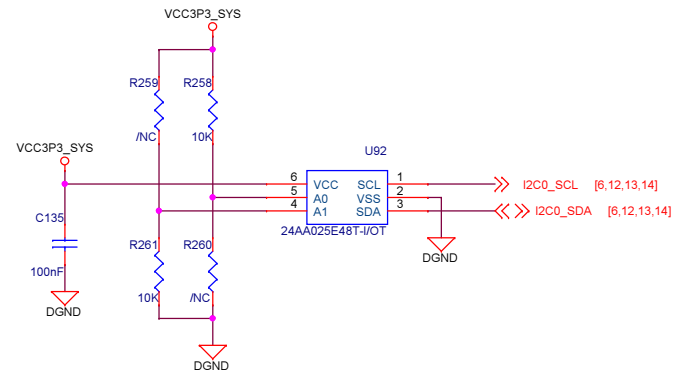

LEDs

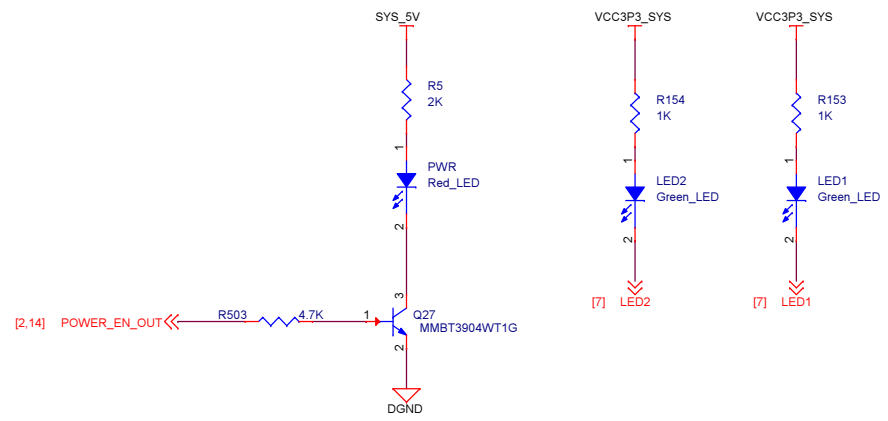

Smart4418/6818		
Size A3	Document Number 13.EEPROM_SHA-256	Rev 1711
Date: Thursday, July 26, 2018	Sheet 13	of 14

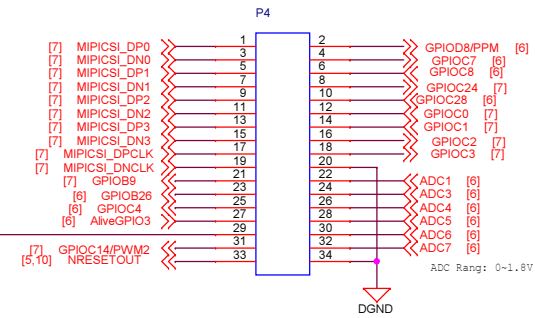
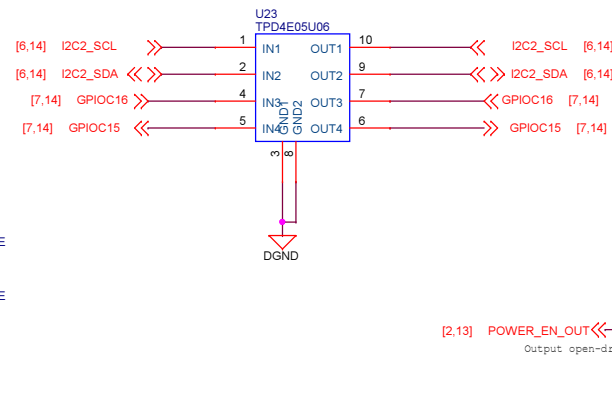
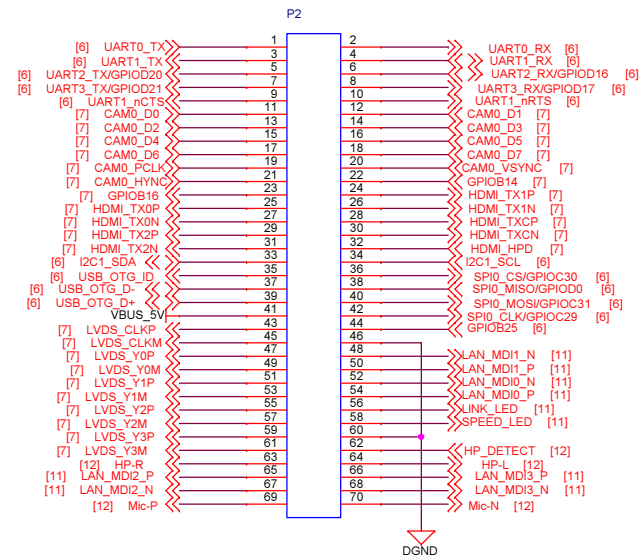
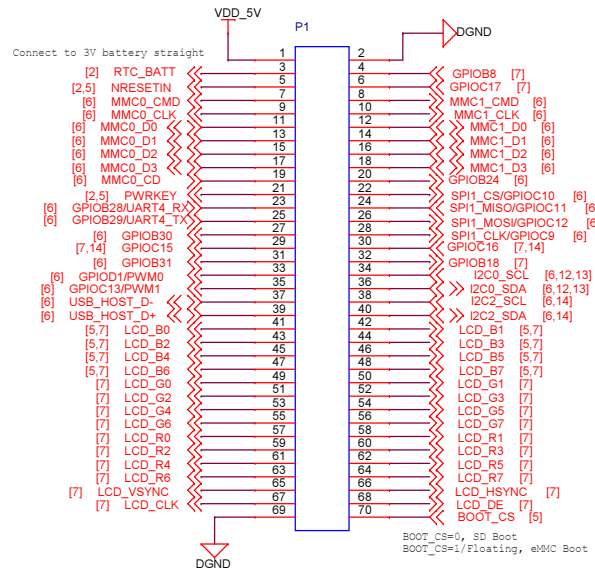

FRIENDLYARM

Smart4418/6818

Size A3	Document Number 14.Connector	Rev 1711
Date: Thursday, July 26, 2018	Sheet 14	of 14