

NanoPi M4B

Revision 1909

I2C device list :
I2C0 (3V), SYR838PKC, SYR837, RK808-D
I2C1 (1.8V) CSI0, ALC5651,
I2C2 (1.8V) CSI1
I2C3 (3V)
I2C4 (1.8V)
I2C5
I2C6
I2C7 (1.8V) HDMI
I2C8



NanoPi M4B		
Size A3	Document Number 01.Title	Rev 1909
Date:	Tuesday, November 26, 2019	Sheet 1 of 23

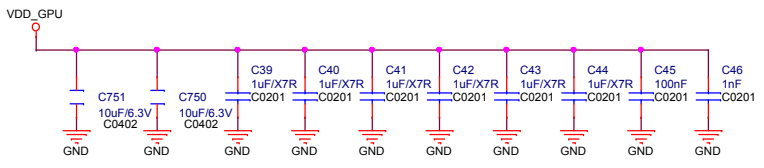
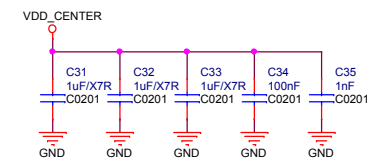
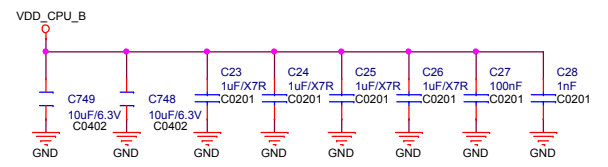
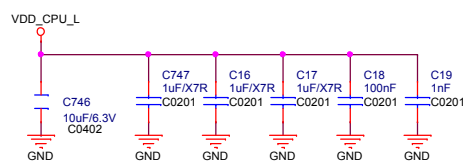
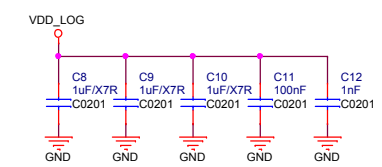
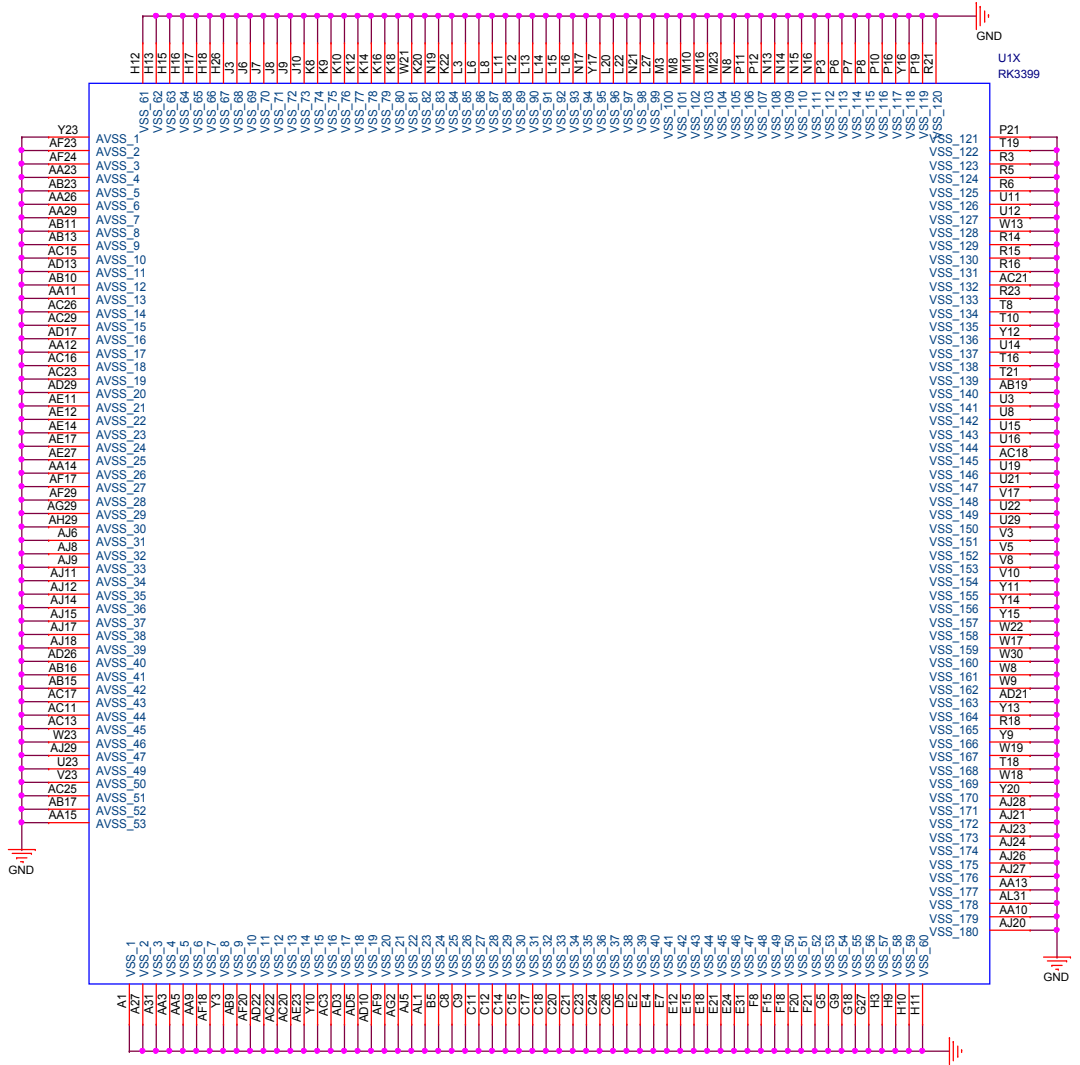
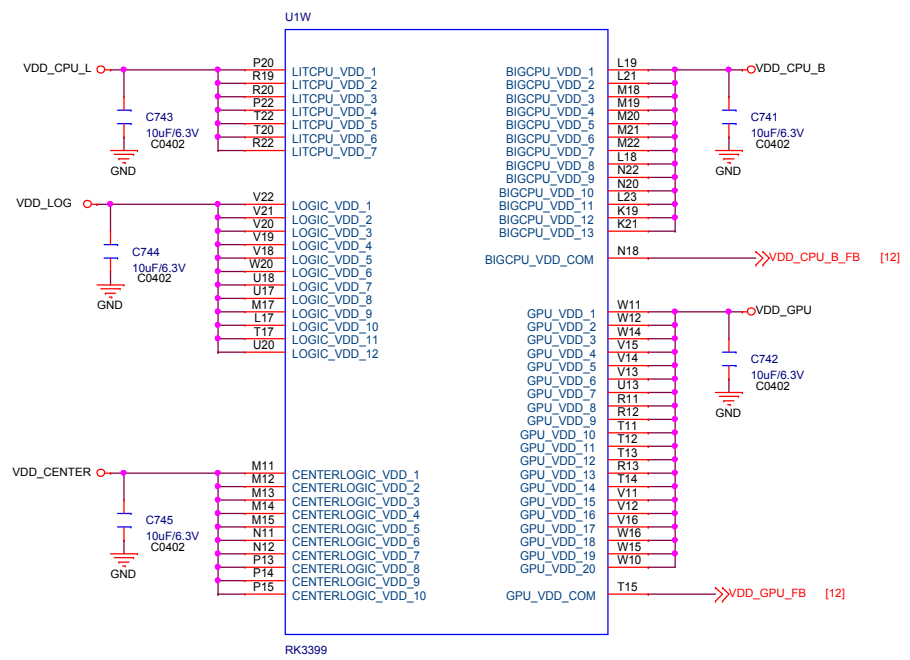

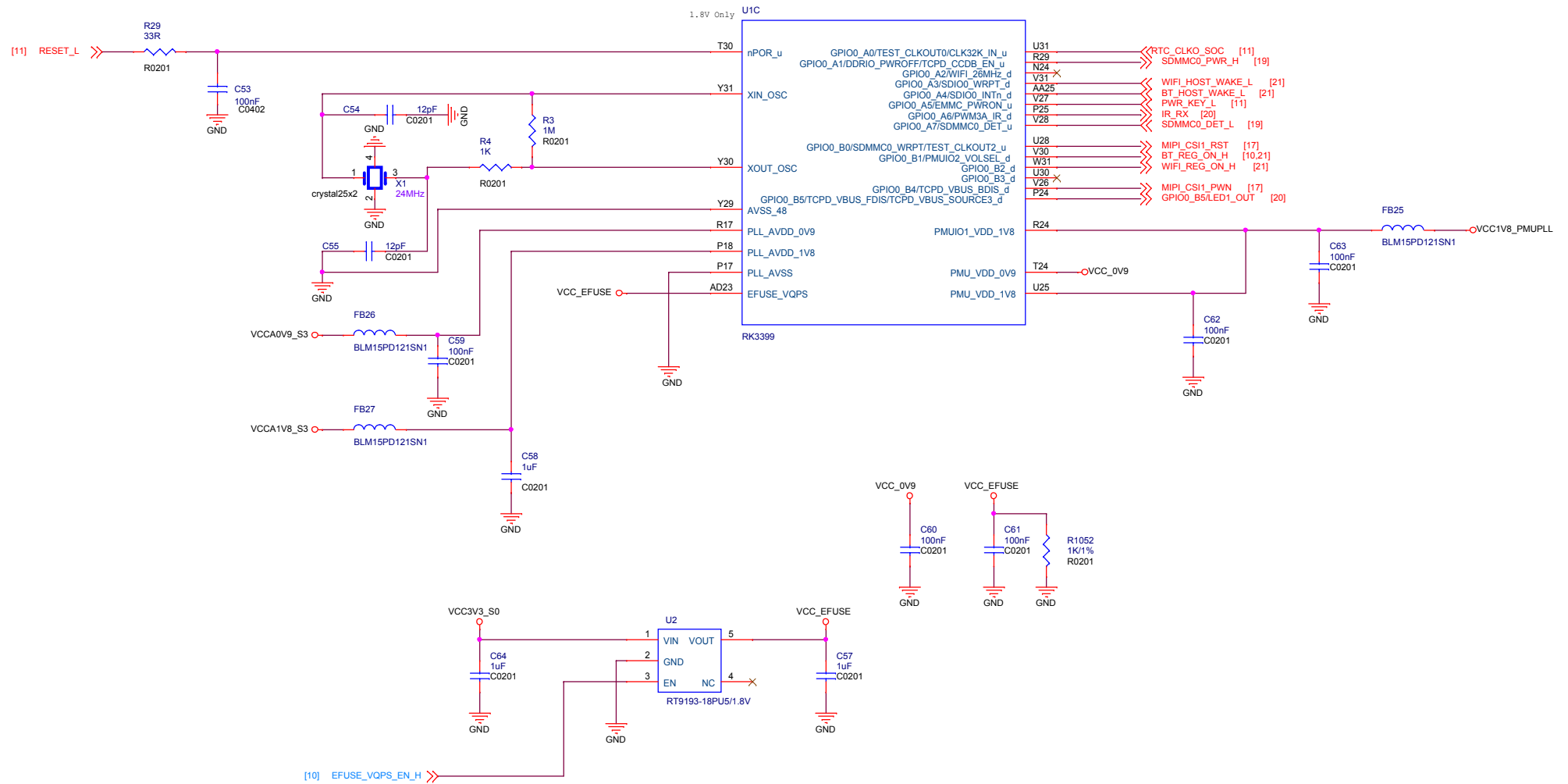

NanoPi M4B		
Size A3	Document Number 03.RK3399 PMU Controller	Rev 1909
Date: Tuesday, November 26, 2019	Sheet 3	of 23

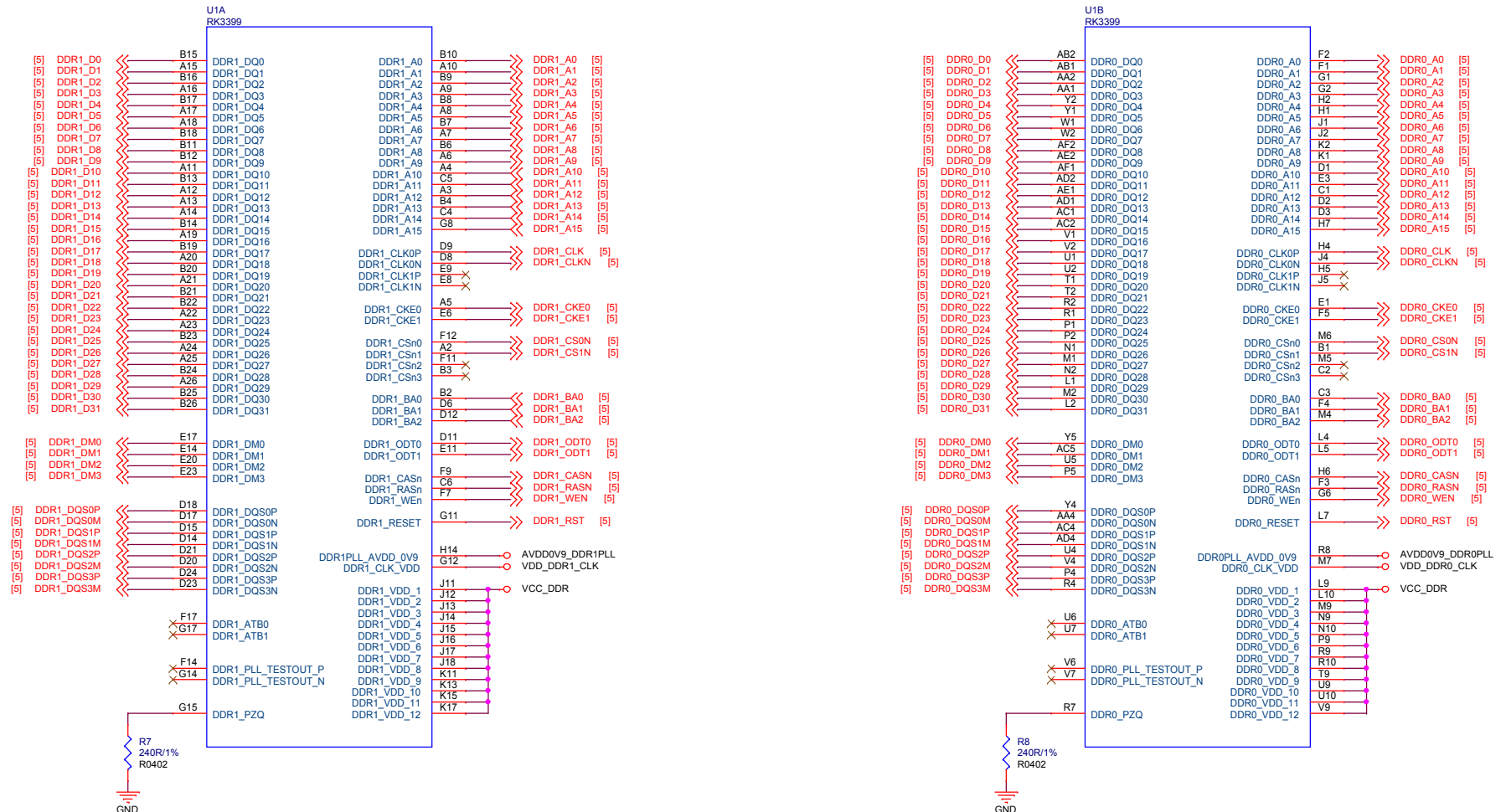

DDR FILTER

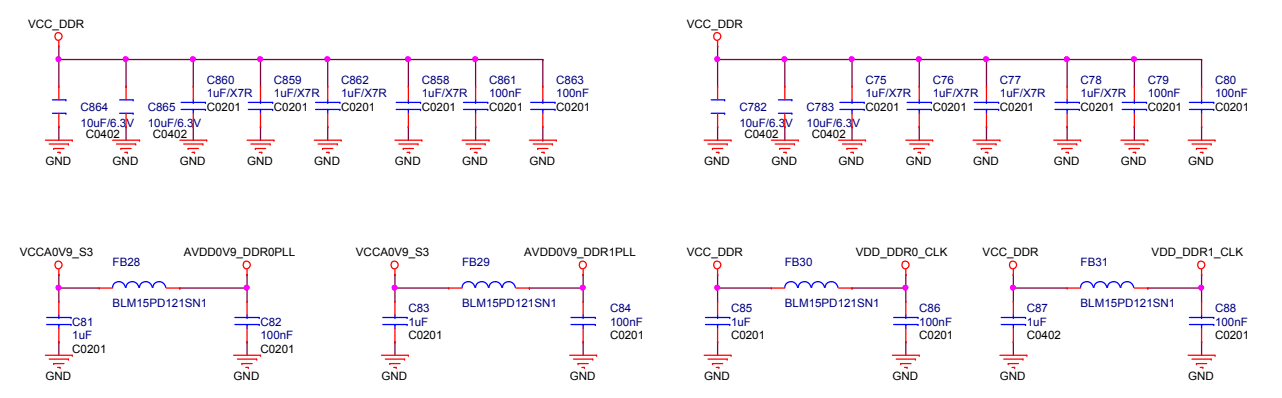



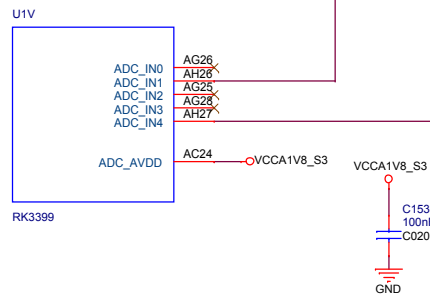
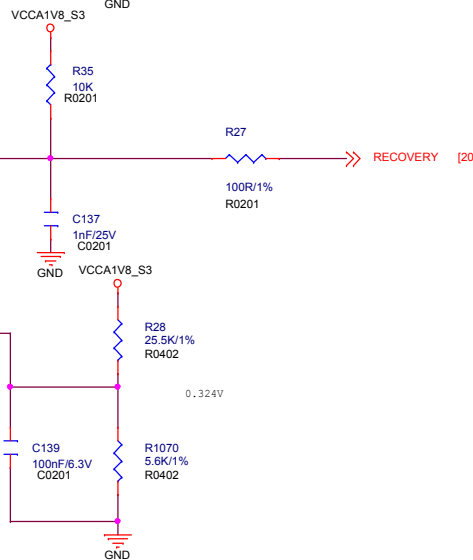
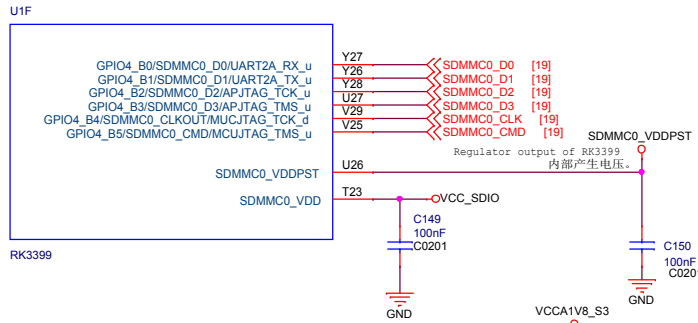
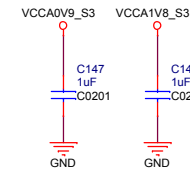
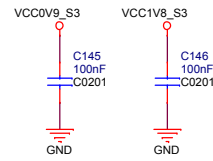
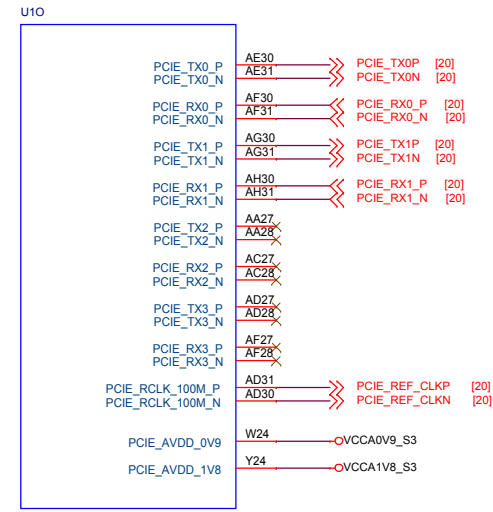
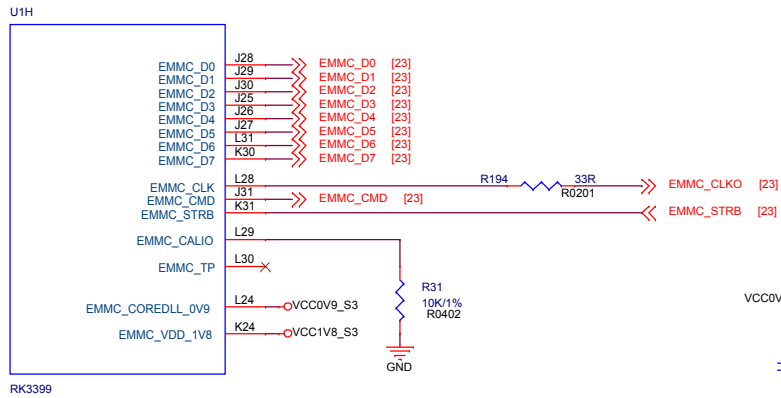

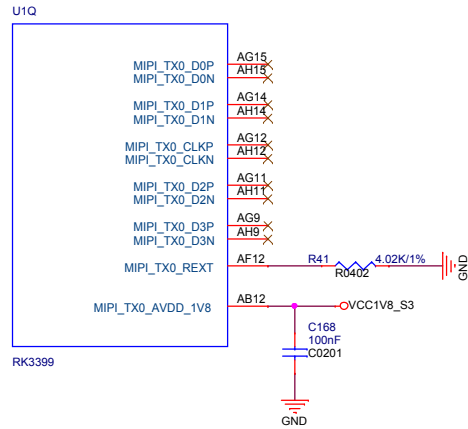
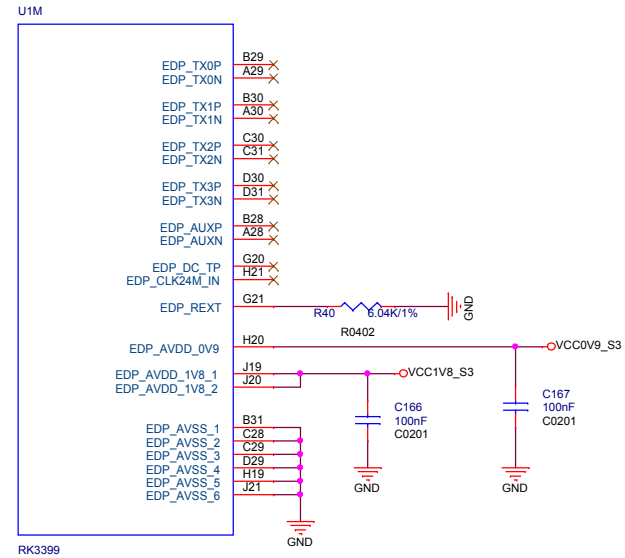
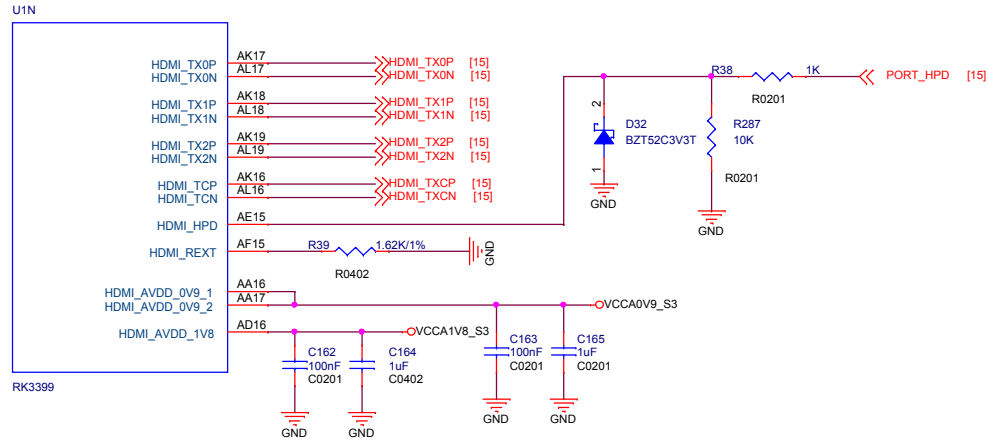

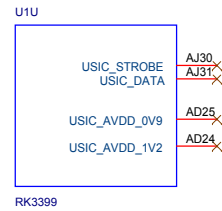
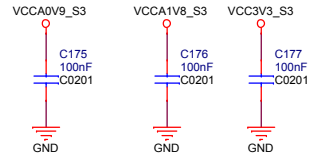
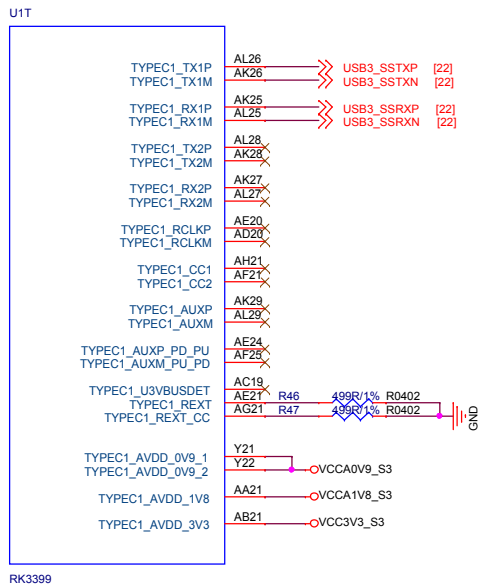
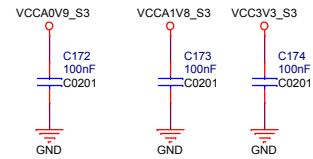
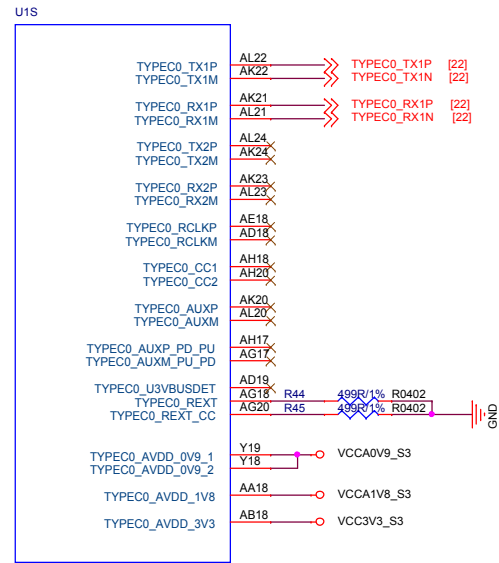
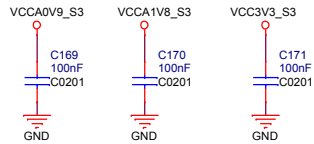
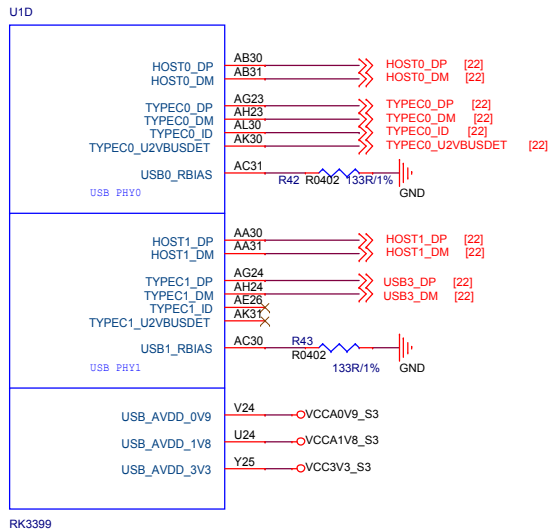

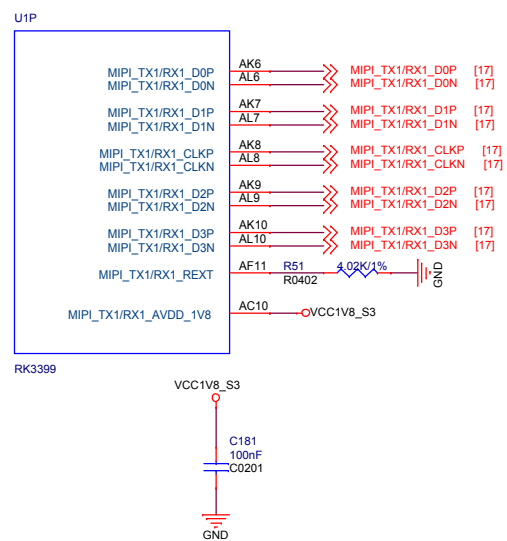
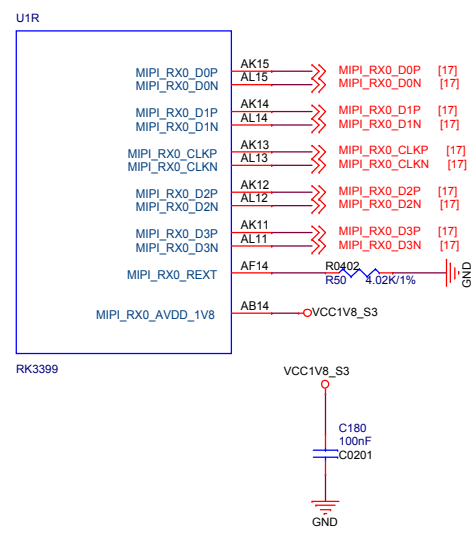
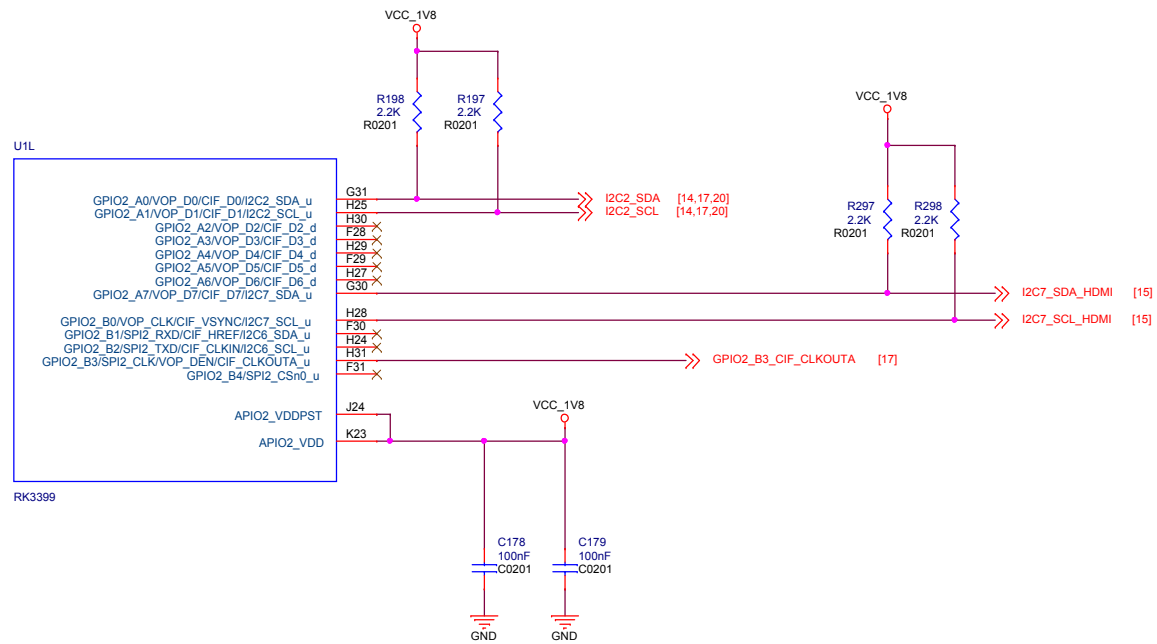

PMIC RK808

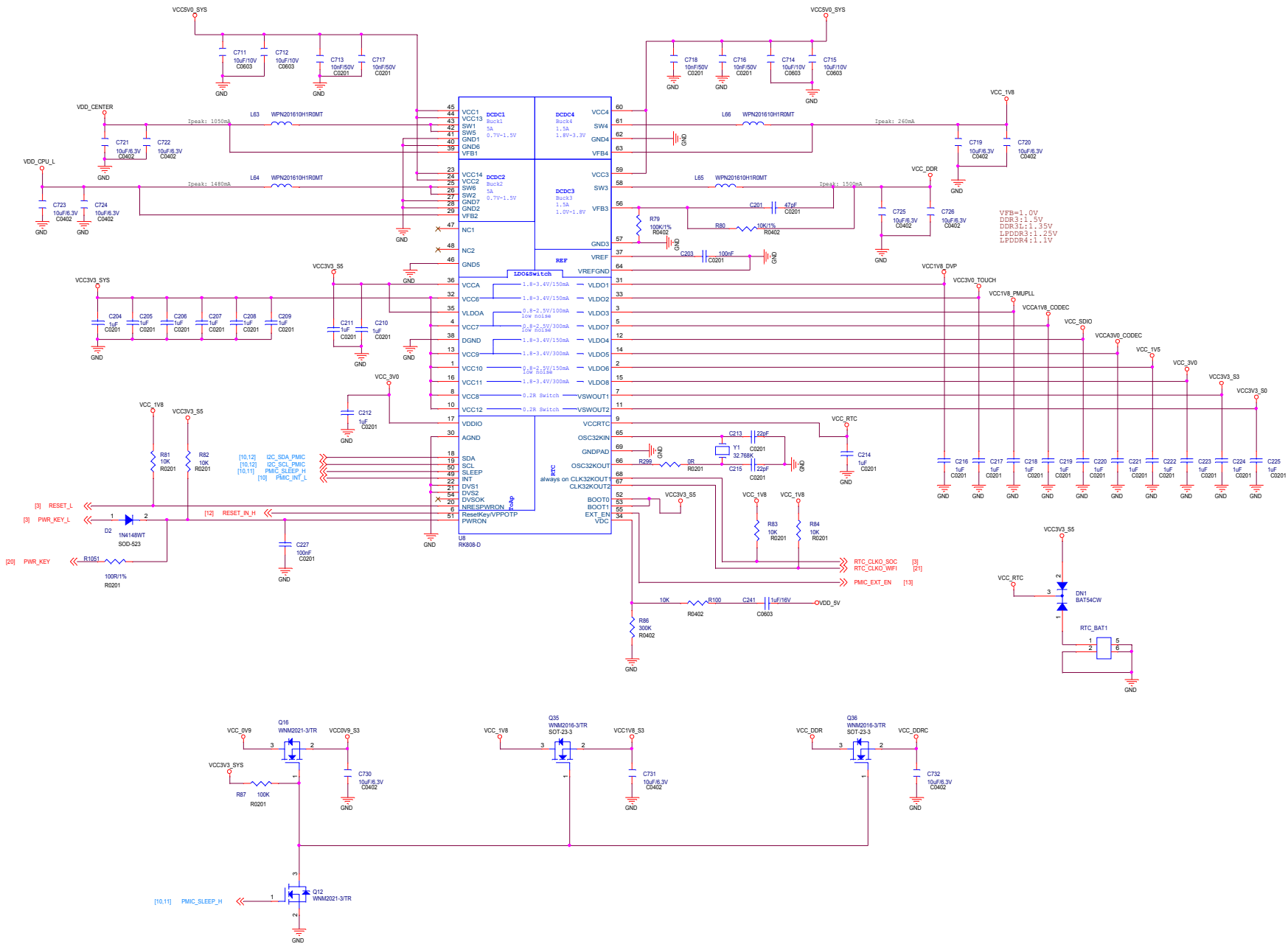

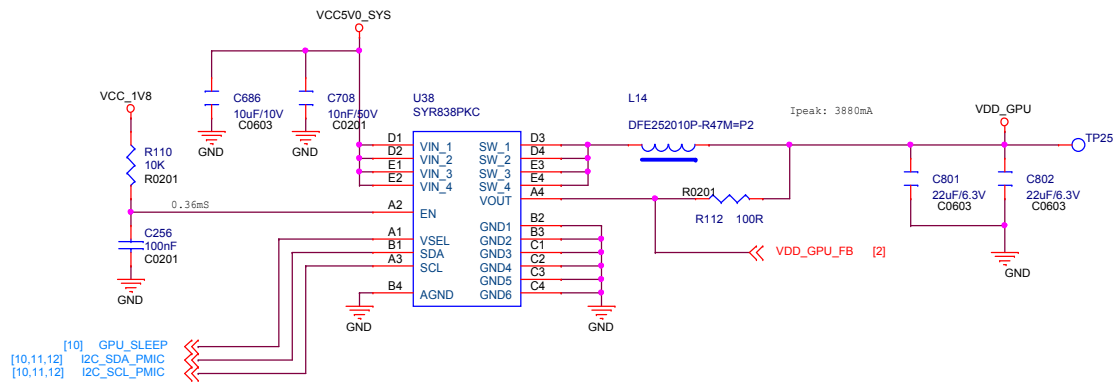

Over-temperature Protection

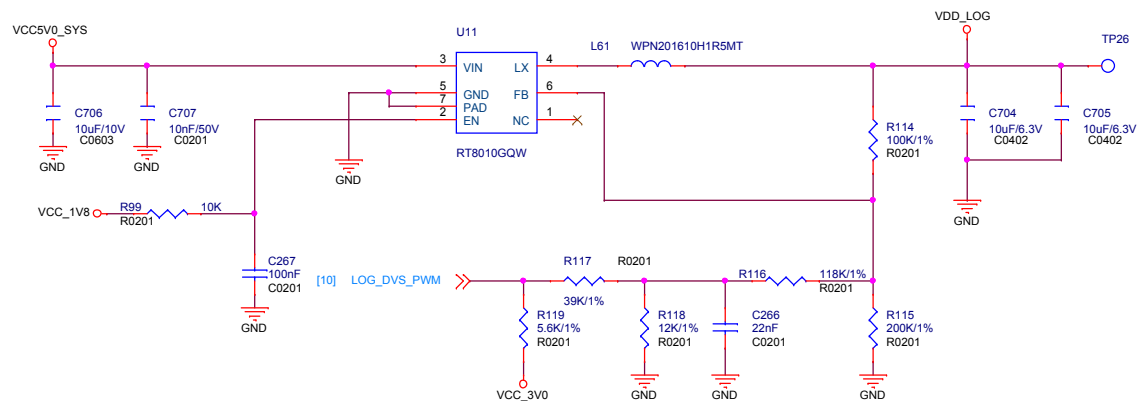
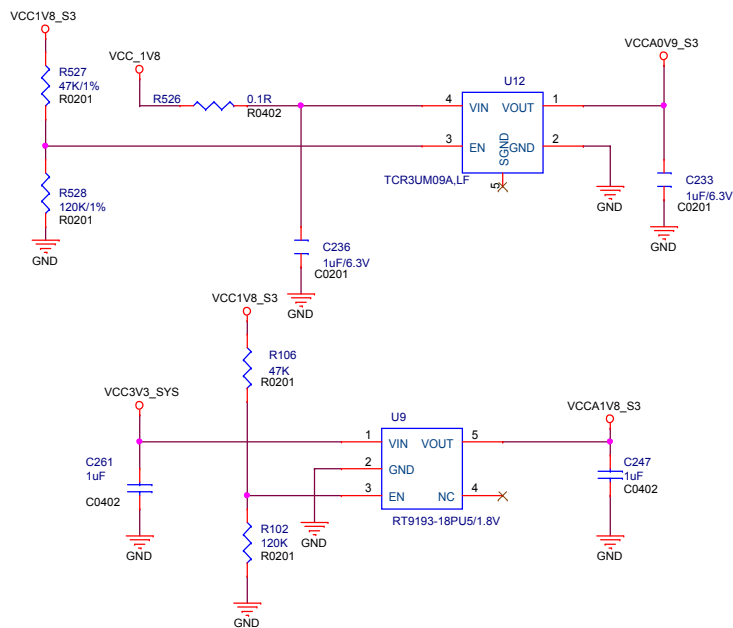
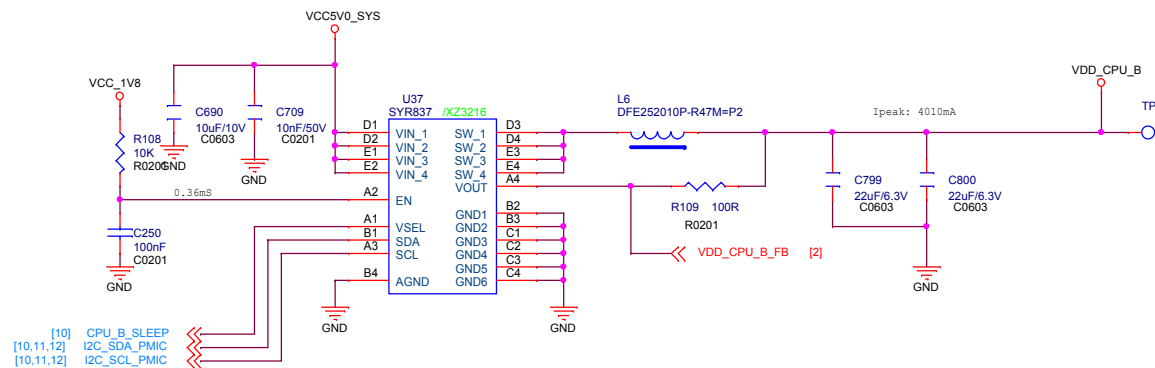
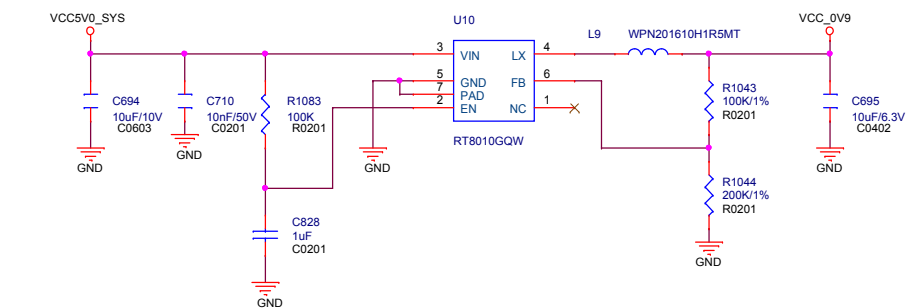
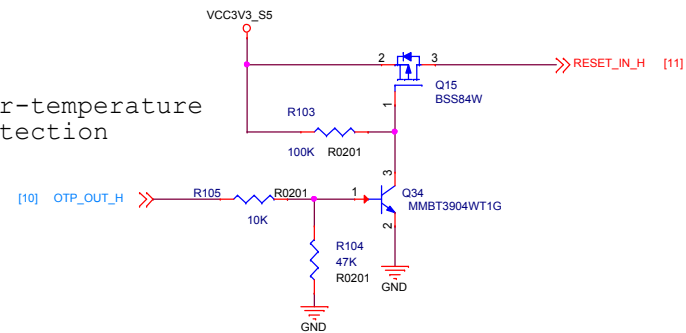

NanoPi M4B		
Size A3	Document Number 12.Power2-CPU/GPU/etc	Rev 1909
Date:	Tuesday, November 26, 2019	Sheet 12 of 23

Power Supply

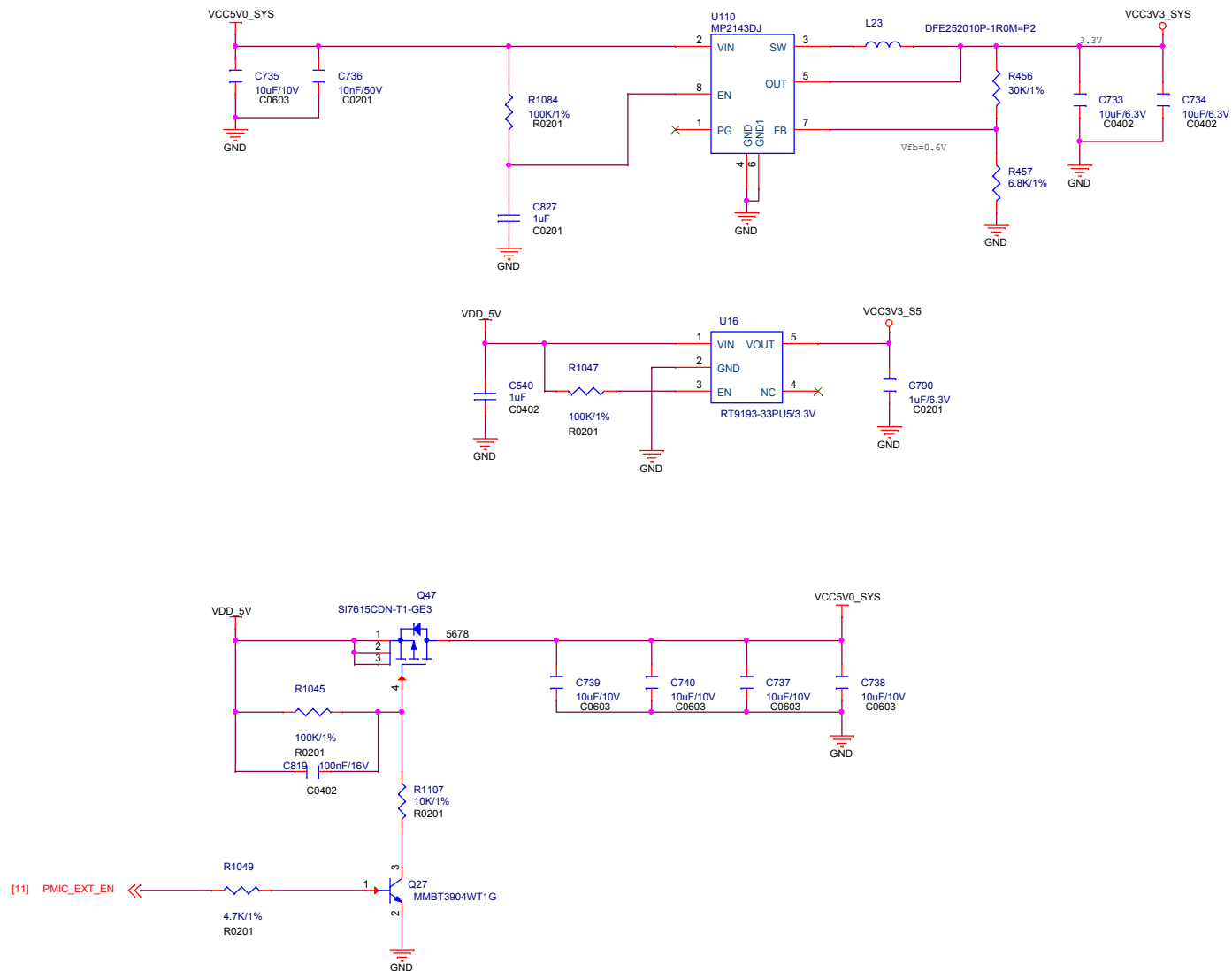

HDMI Port

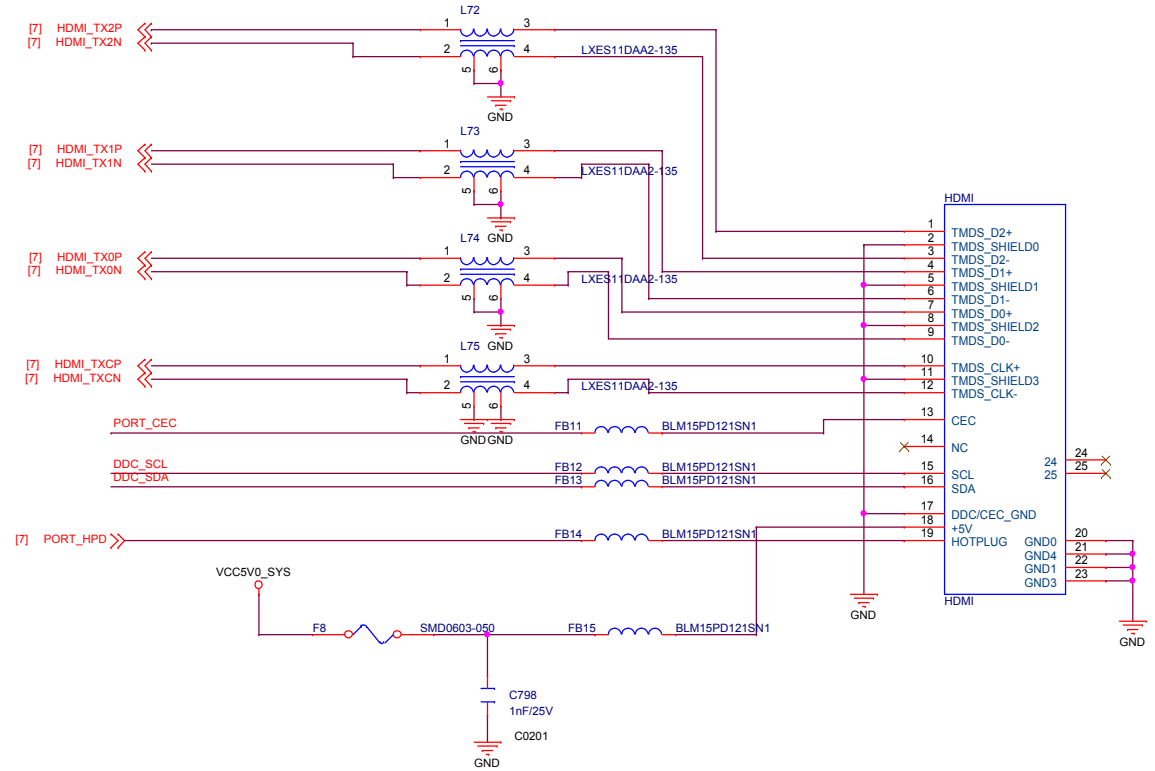
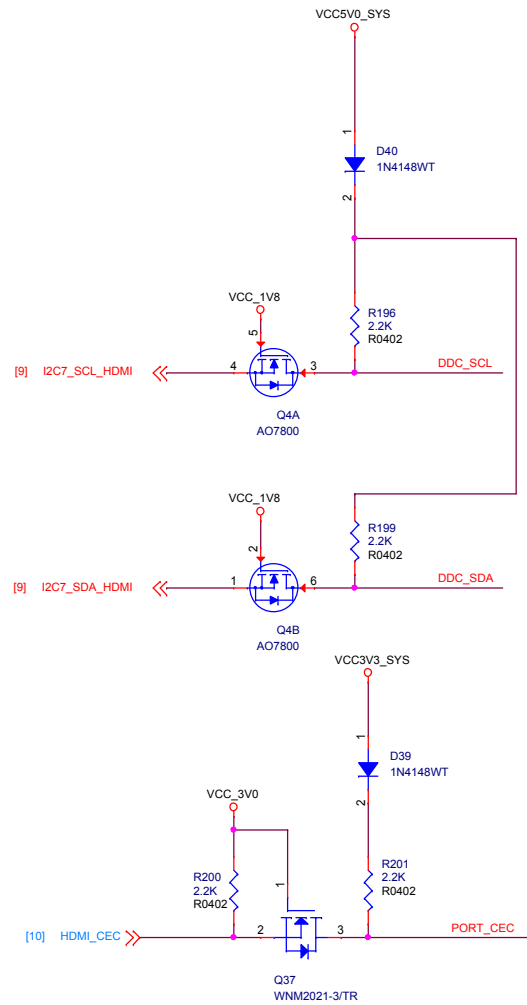

USB Type-C

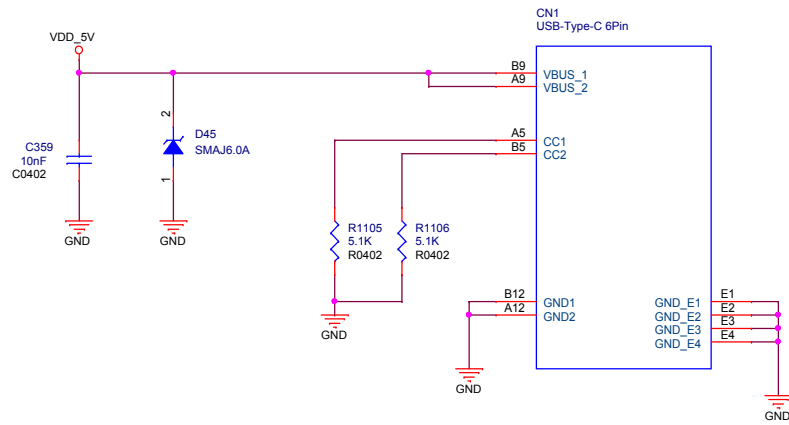

MIPI-CSI

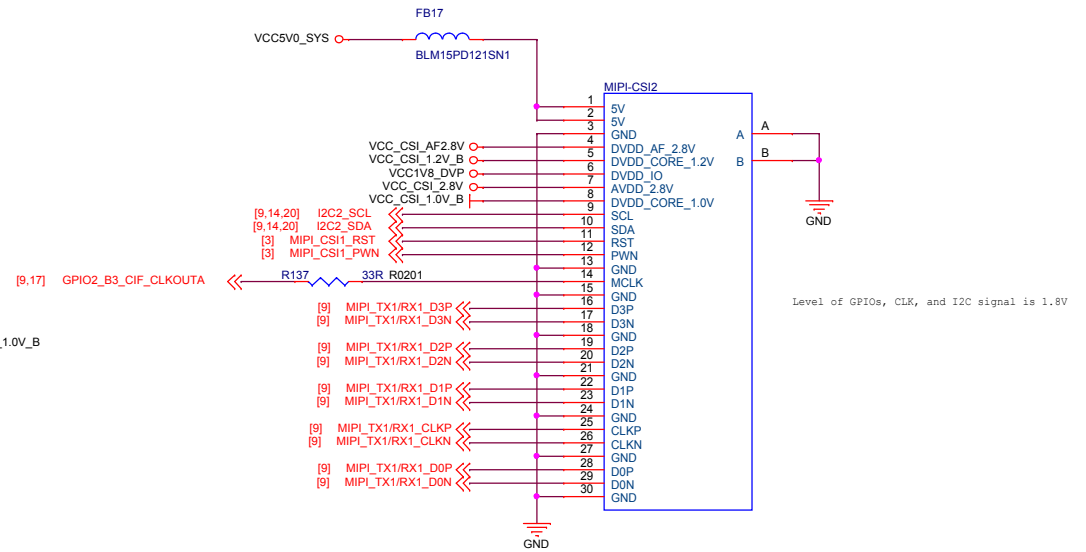
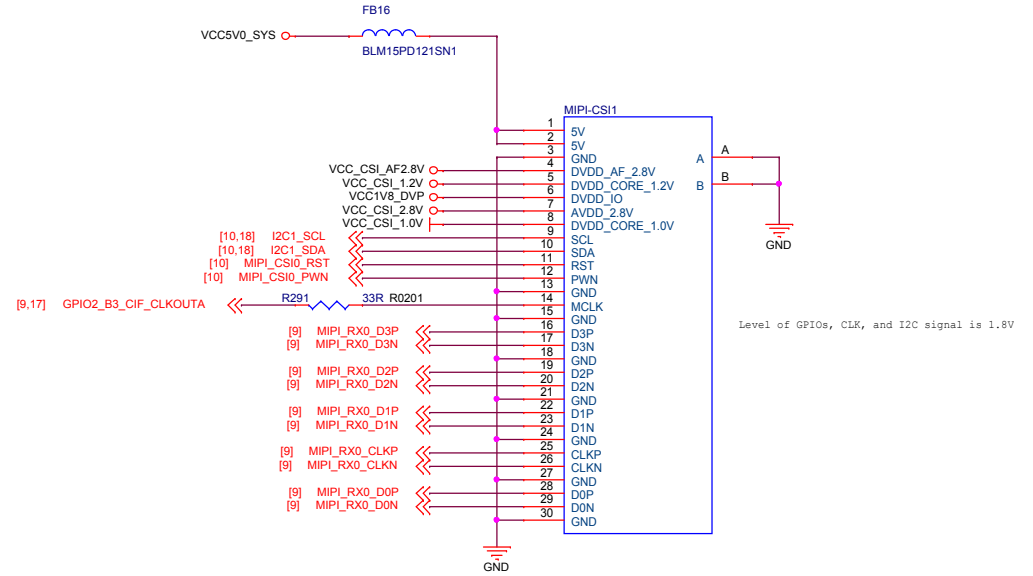
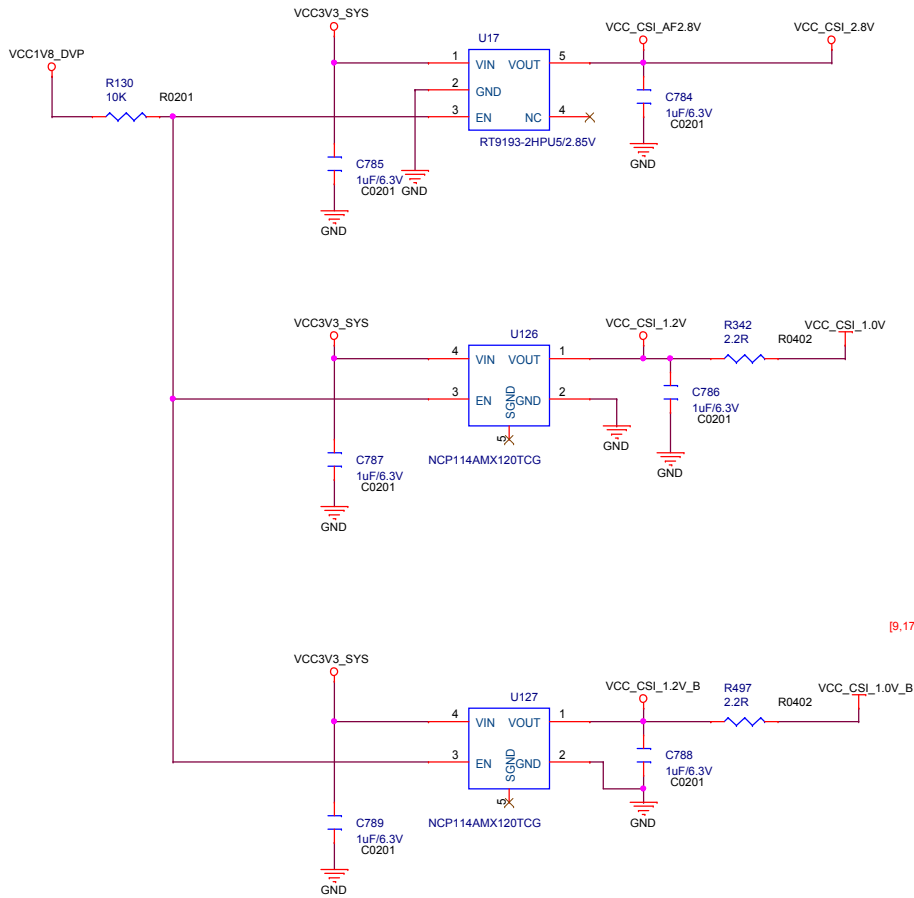

NanoPi M4B		
Size A3	Document Number 17.MIPI-CSI	Rev 1909
Date: Tuesday, November 26, 2019	Sheet 17	of 23

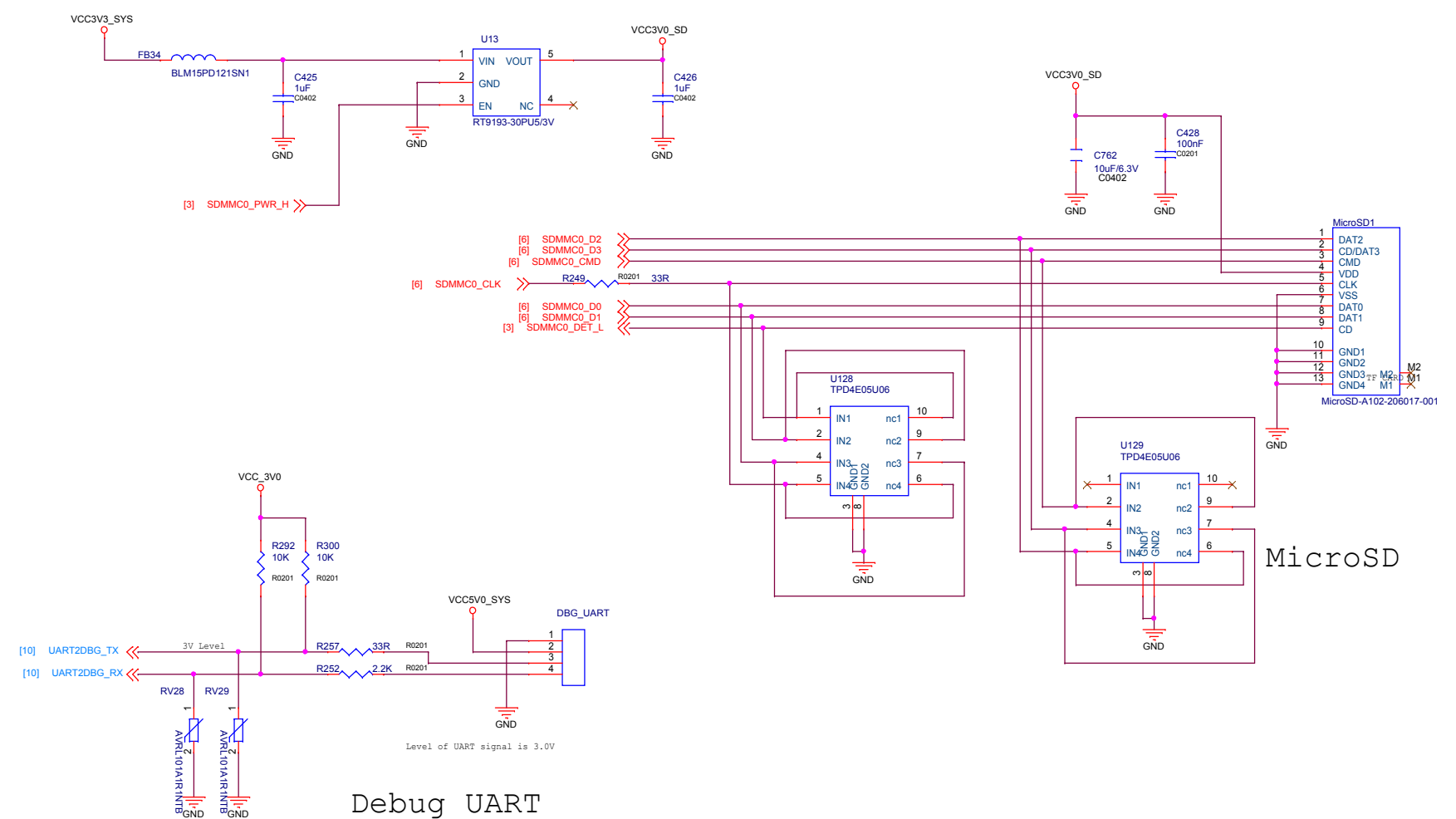

MicroSD

Debug UART



GPIO

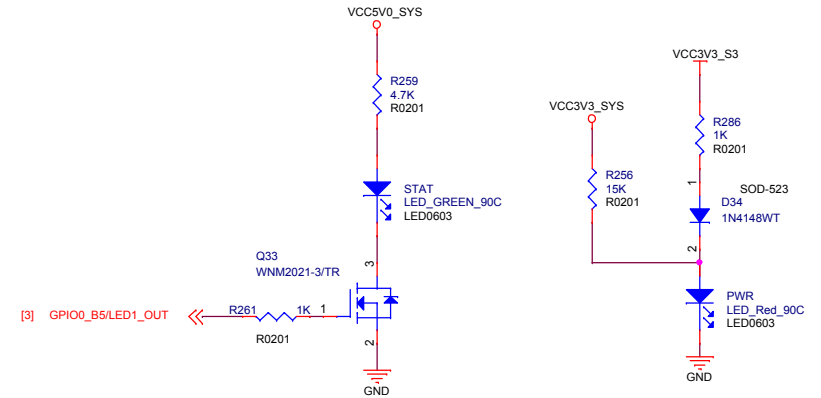
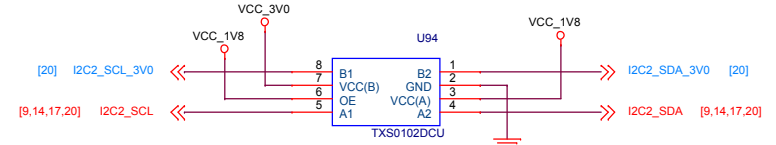
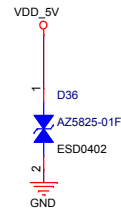
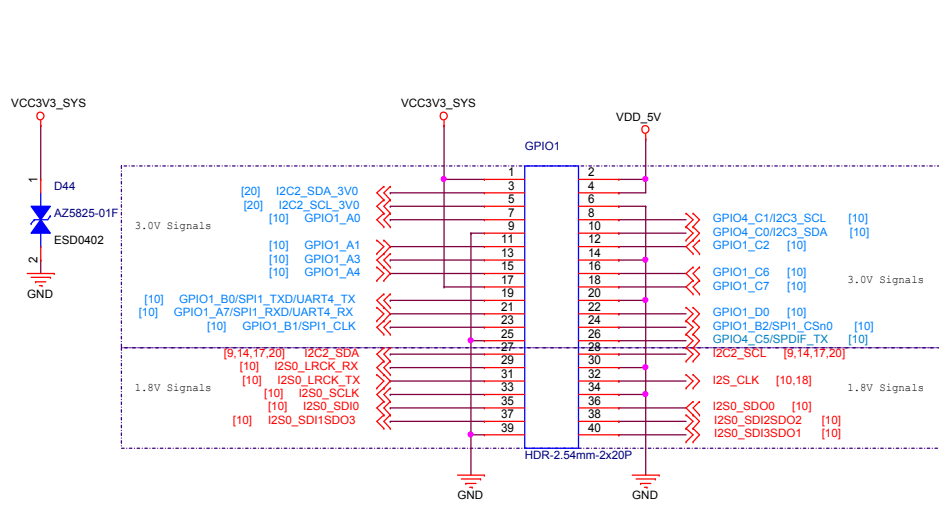

PCIe, USB

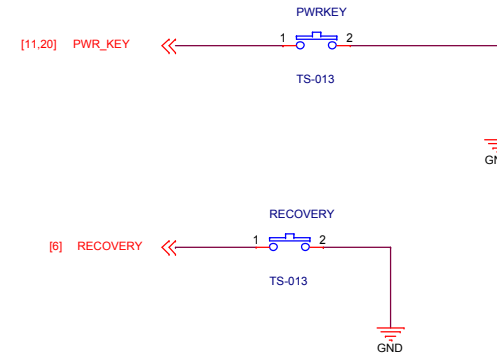
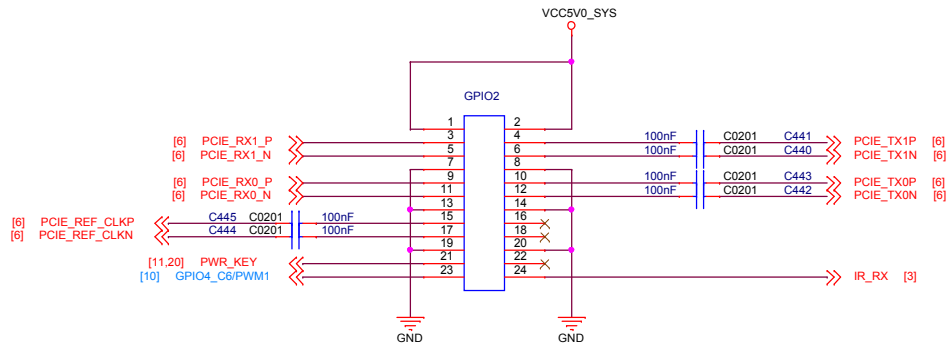

Wi-Fi/Bluetooth

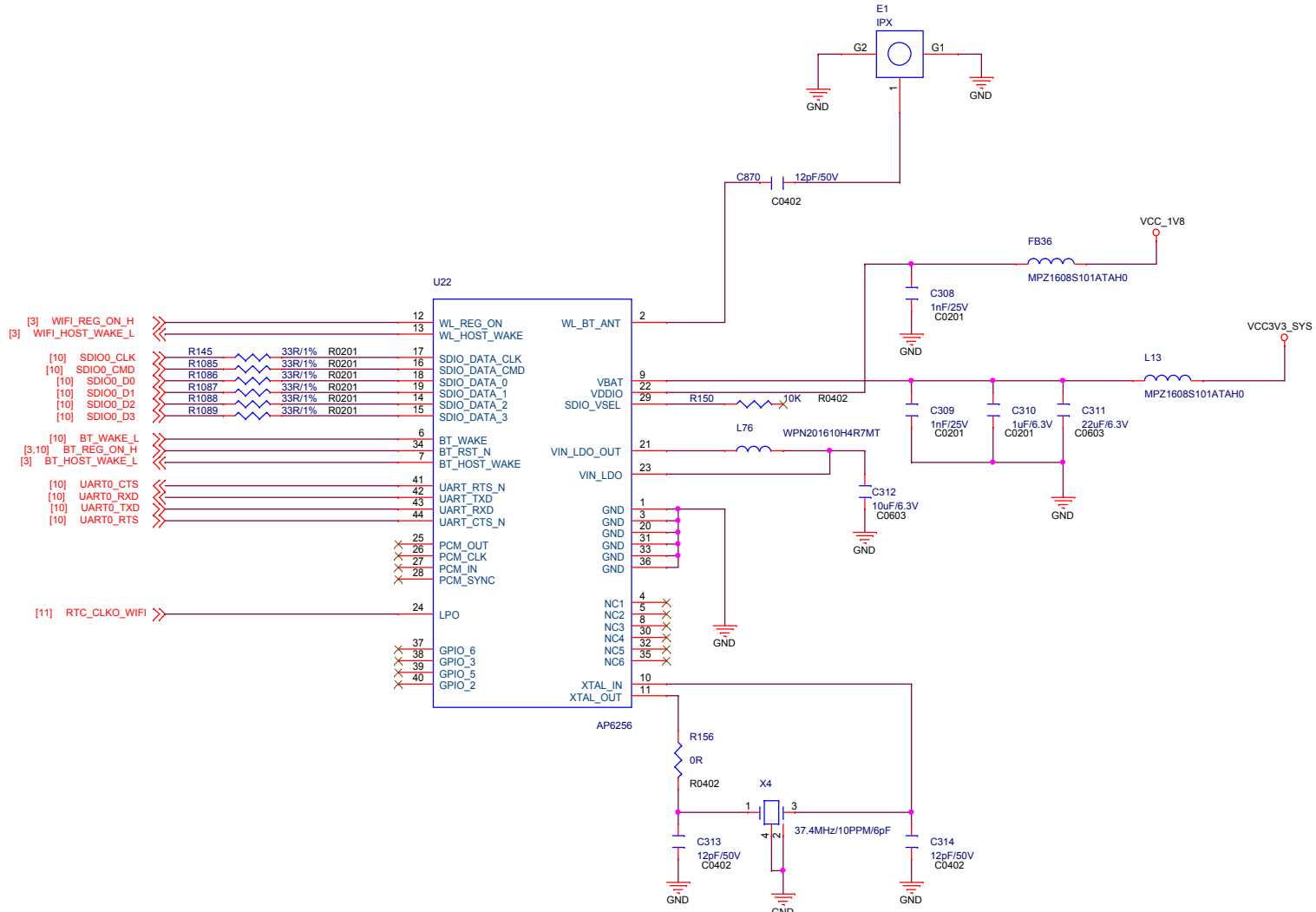

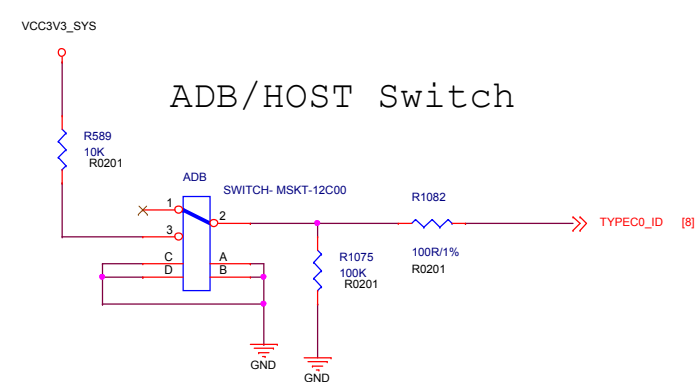
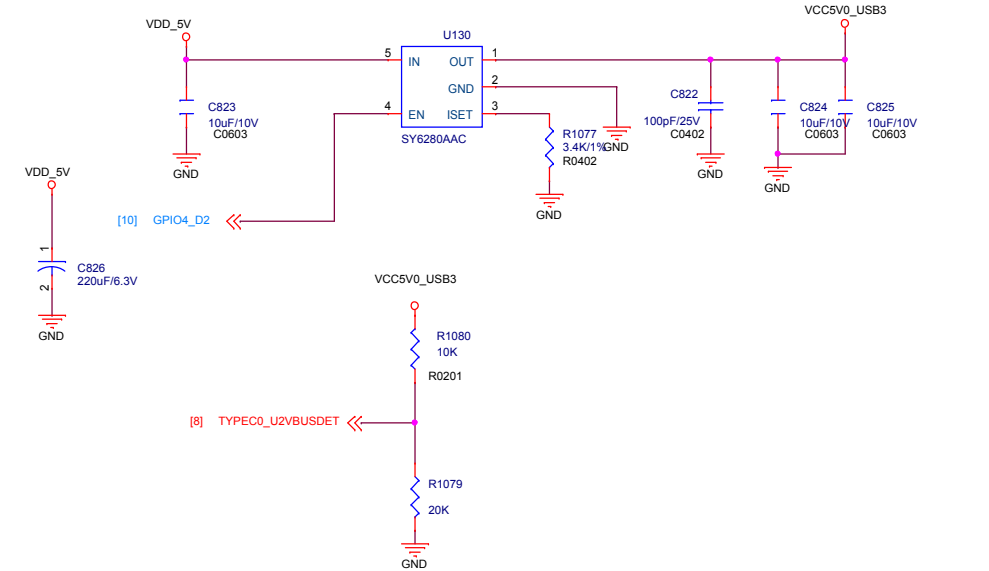
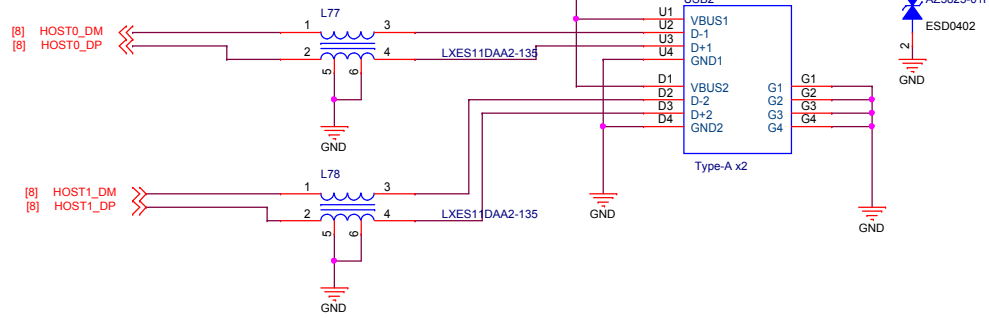
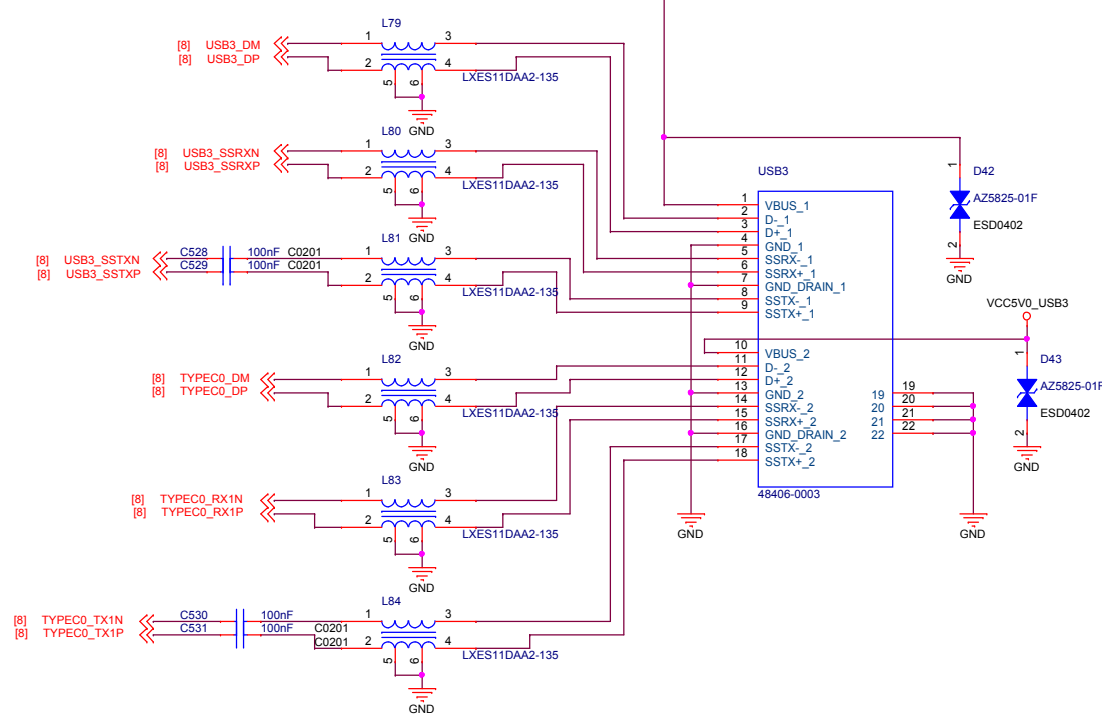
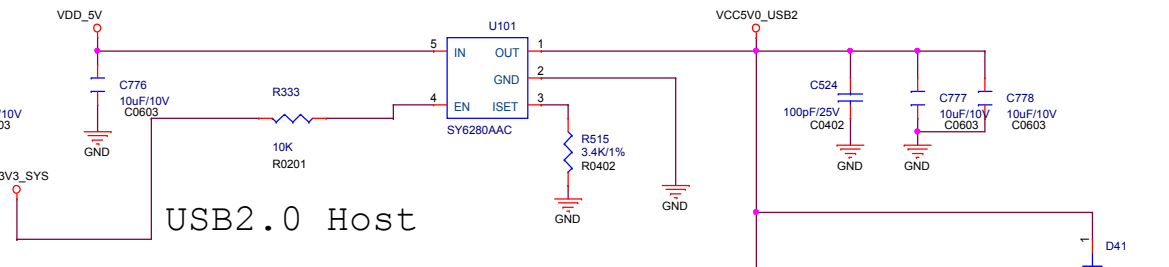
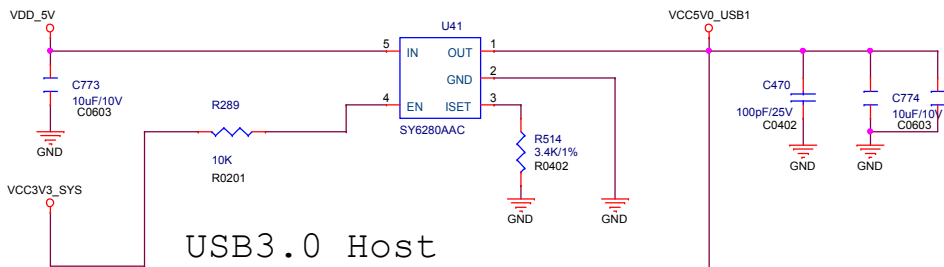

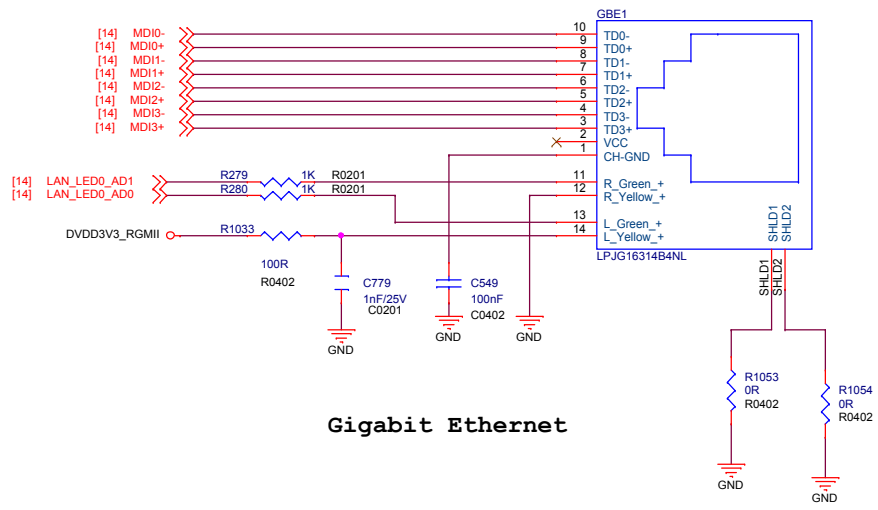

Gigabit Ethernet

Gigabit Ethernet

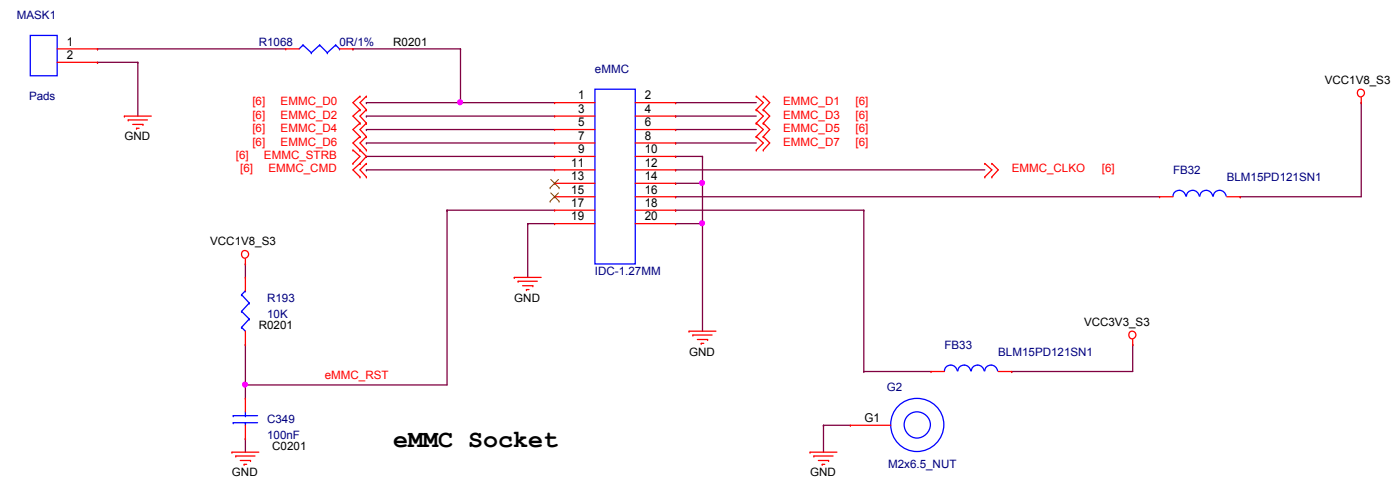
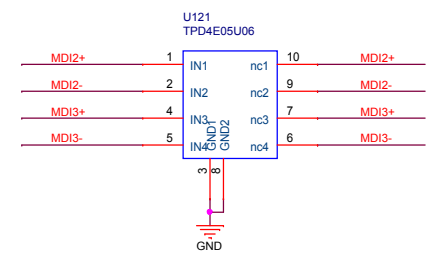
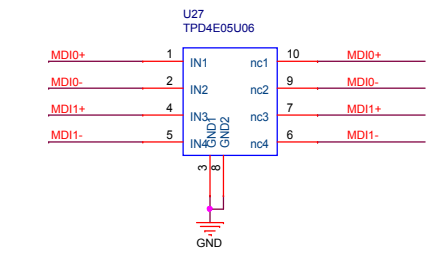

eMMC Socket



NanoPi M4B		
Size A3	Document Number 23.Gigabit Port/eMMC Socket	Rev 1909
Date: Tuesday, November 26, 2019	Sheet 23	of 23