

# Smart4418 SDK

Revision

1606 , First Version



Smart4418		
Size	Document Number	Rev
A3	01.Title	1606
Date:	Wednesday, July 20, 2016	Sheet 1 of 12

# Smart4418 Connectors

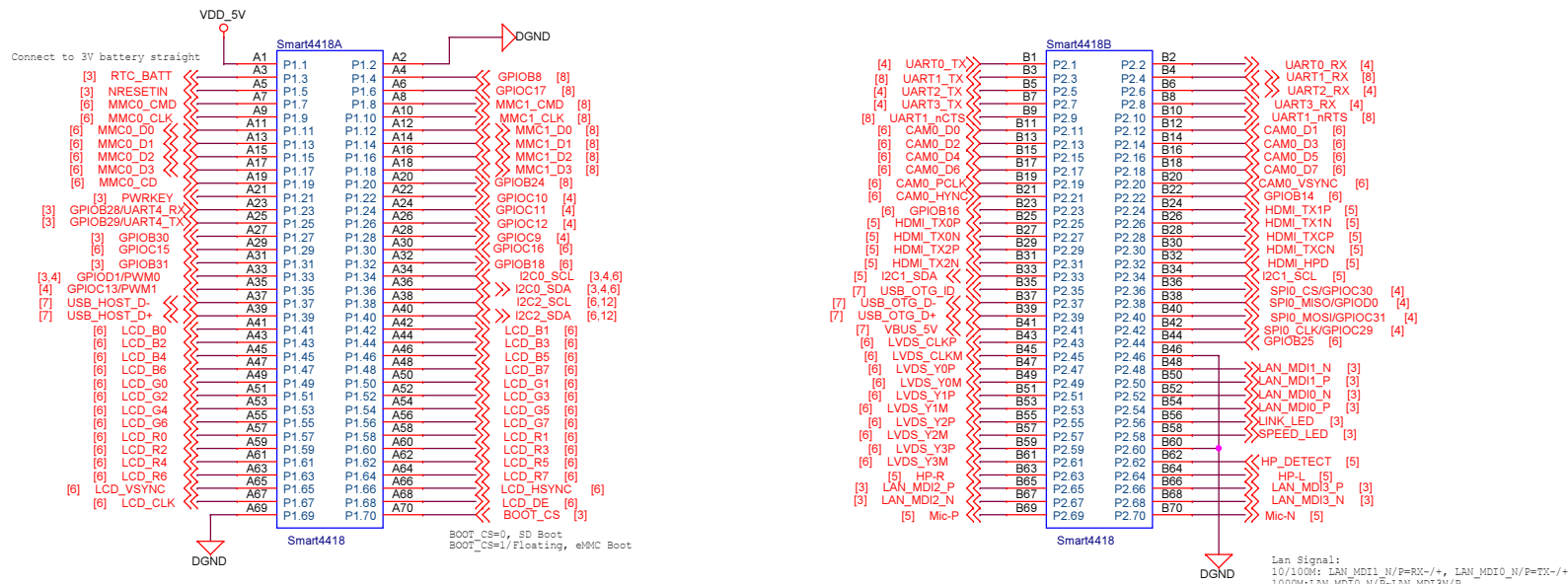

Smart4418		
Size A3	Document Number 12.Connector	Rev 1606
Date: Wednesday, July 20, 2016	Sheet 2	of 12

## Gigabit Ethernet

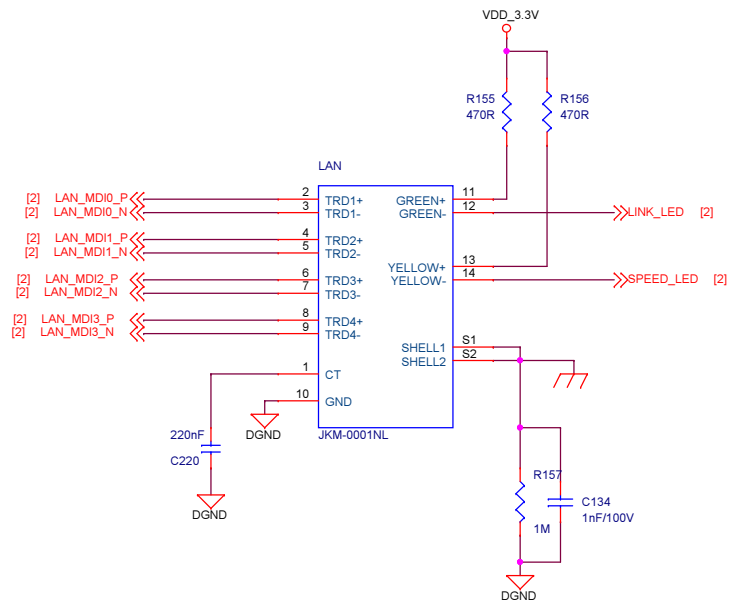

## RTC/Boot Switch/Reset

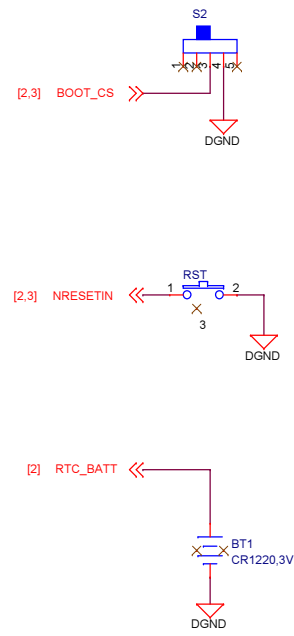

## Buttons

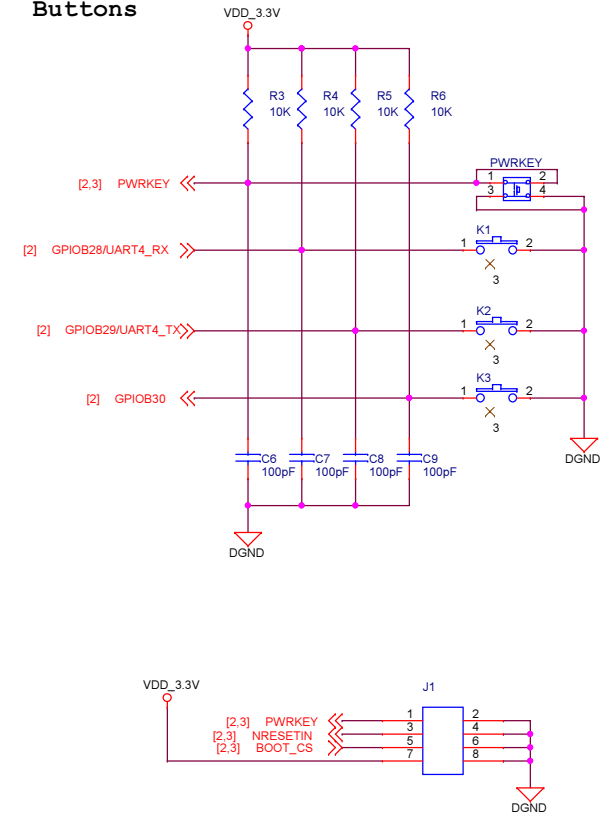

## 3-Axis Sensor

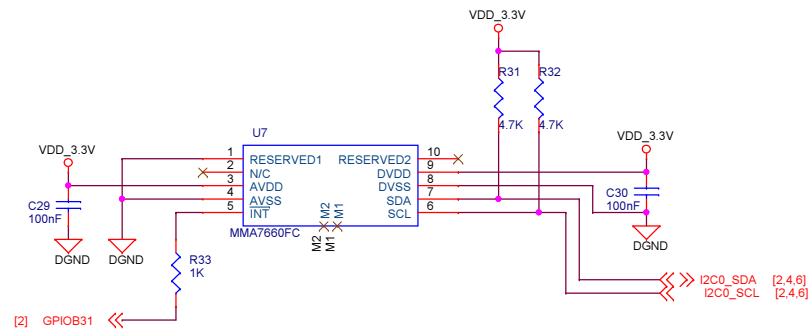

## Buzzer

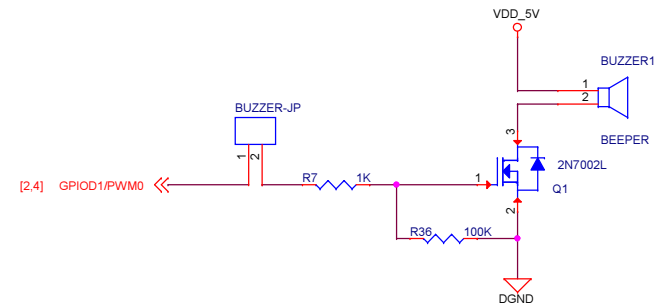

**FRIENDLYARM**

Smart4418		
Size A3	Document Number 03.Lan_Keys,etc	Rev 1606
Date: Wednesday, July 20, 2016	Sheet 3	of 12

# RS-232

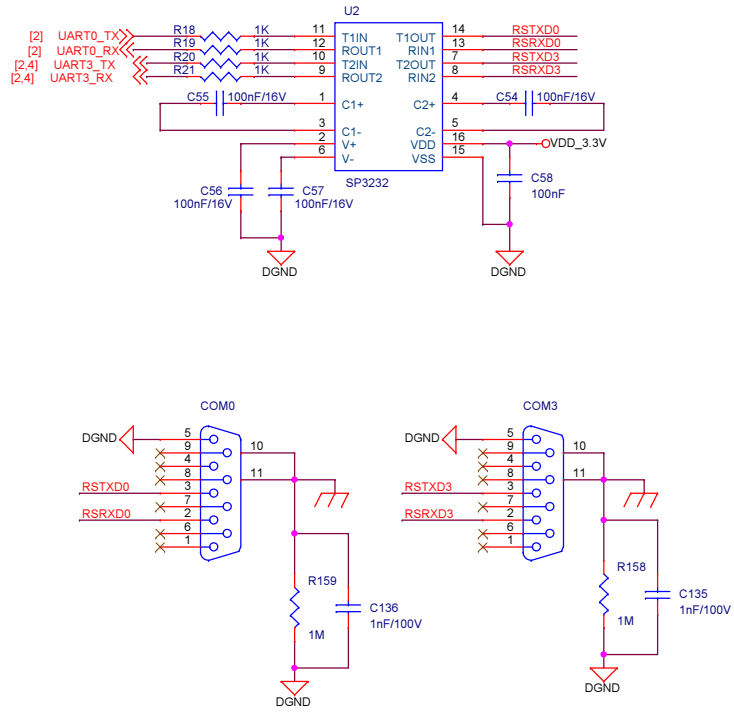

# I2C0/UART2

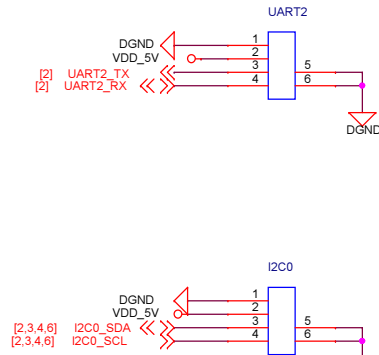

# I2C0/UART3/SPI0/PWMs

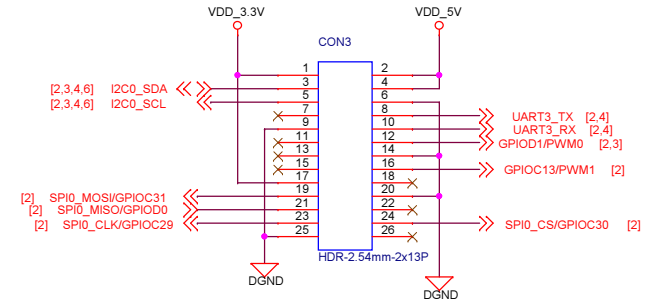

# GPIOs

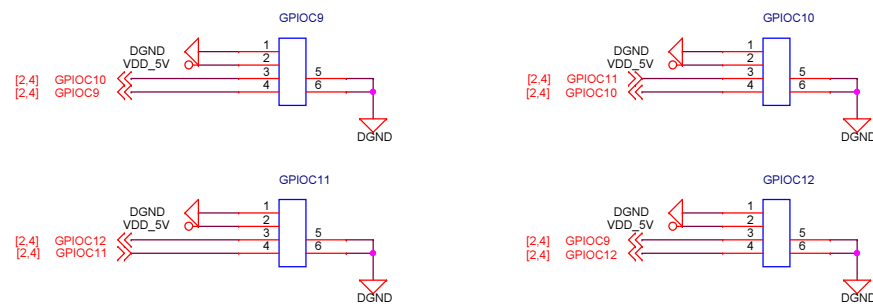

# Mounting Holes

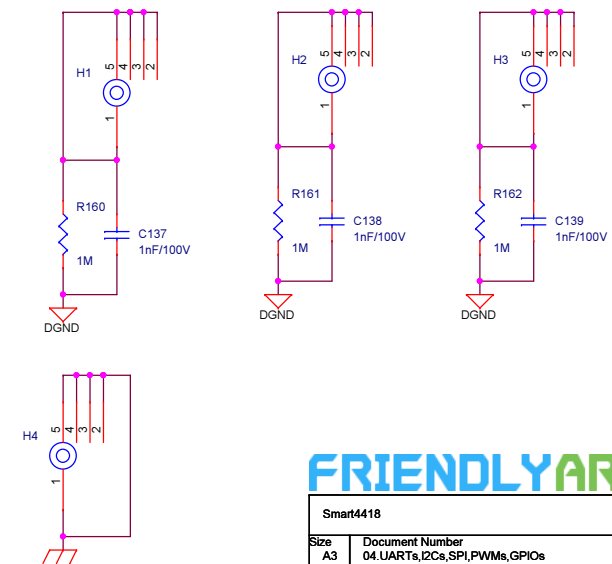

**FRIENDLYARM**

Smart4418		
Size A3	Document Number 04.UARTs,I2Cs,SPI,PWMs,GPIOs	Rev 1606
Date: Wednesday, July 20, 2016	Sheet 4	of 12

# HDMI

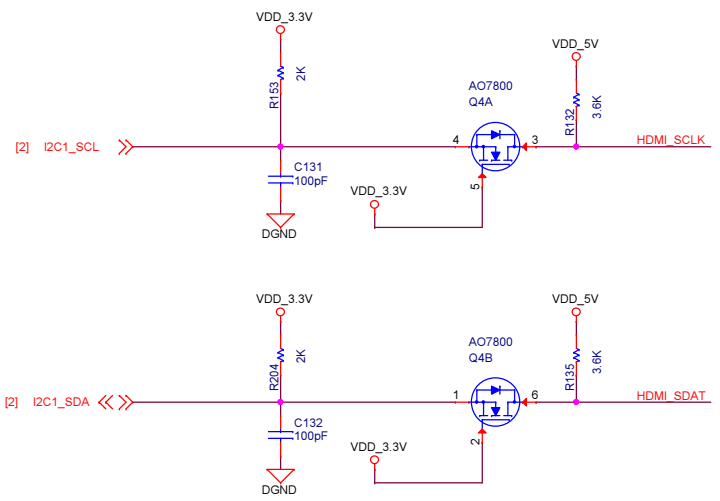
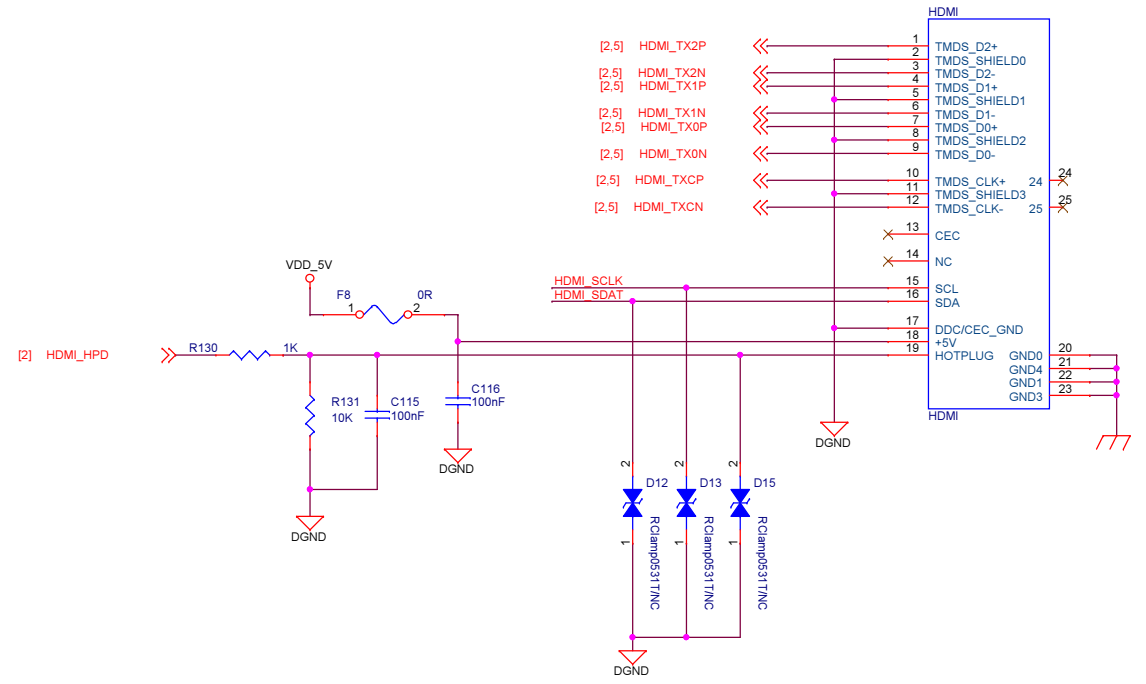
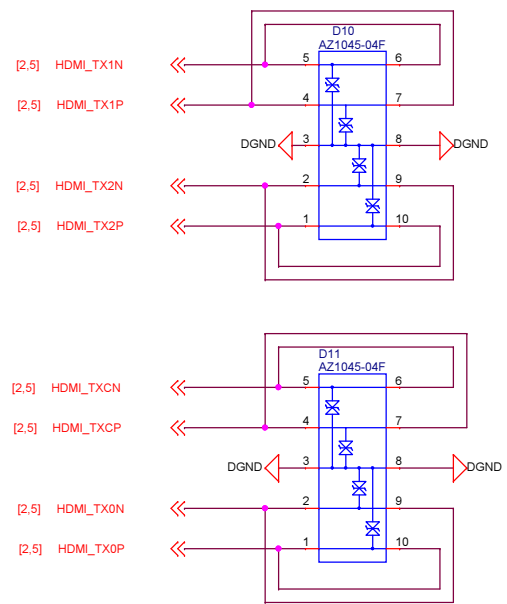

# Audio

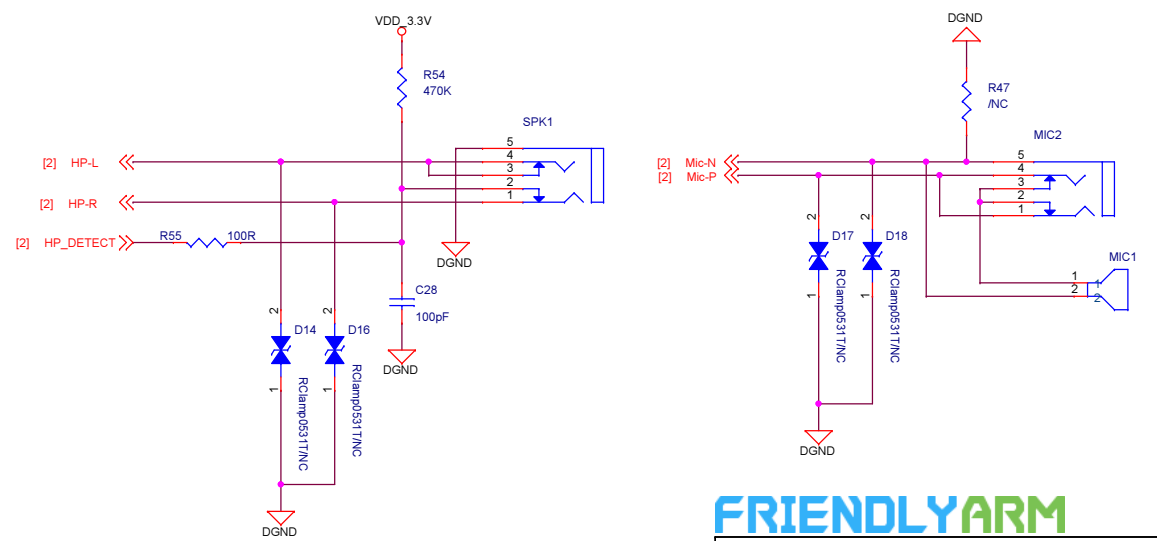

Smart4418		
Size A3	Document Number 05.HDMI_Audio	Rev 1606
Date: Wednesday, July 20, 2016	Sheet 5	of 12

### LVDS

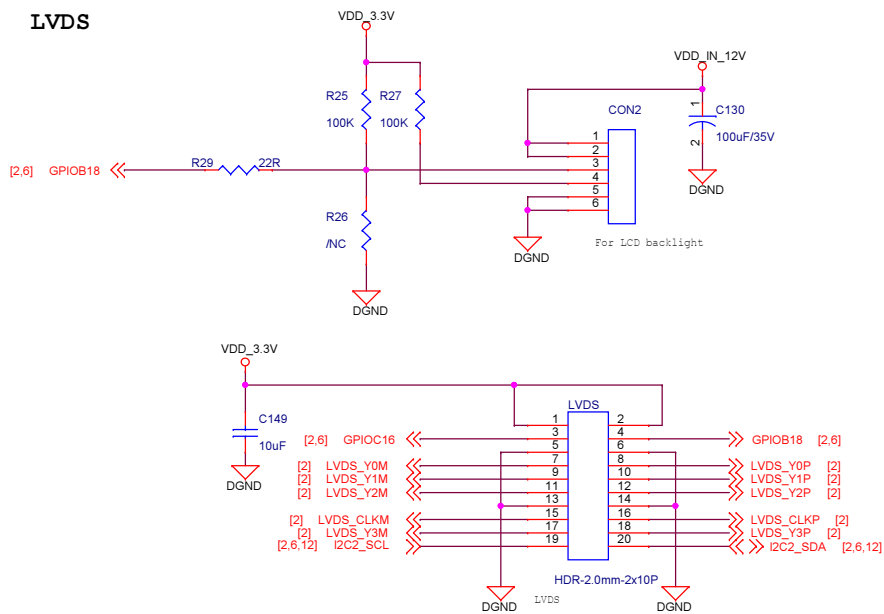

### RGB LCD

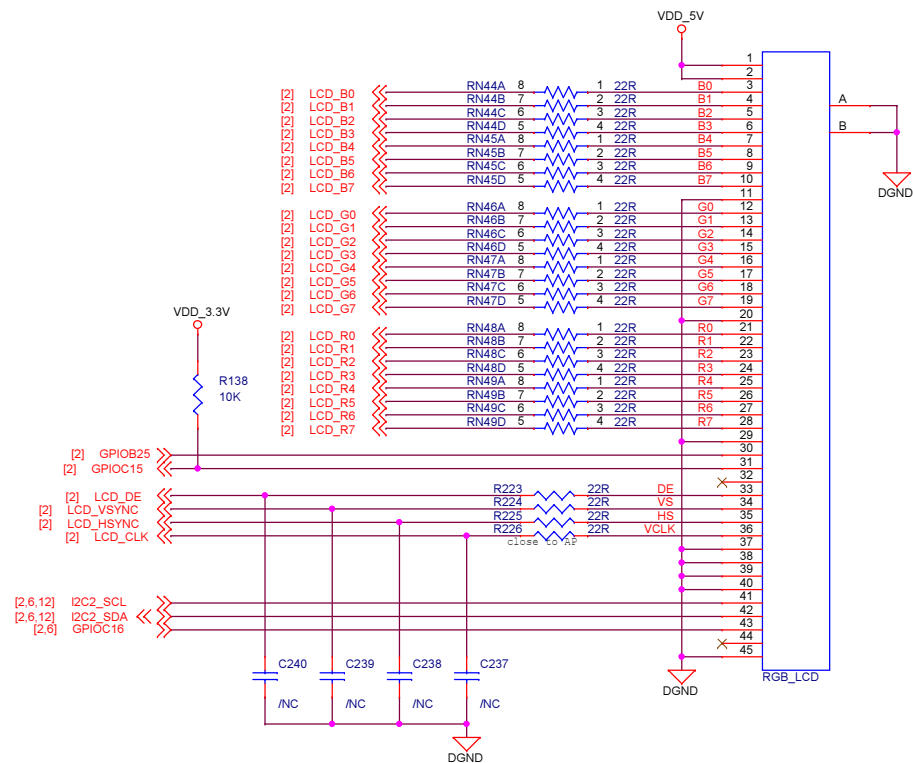

### SD Card

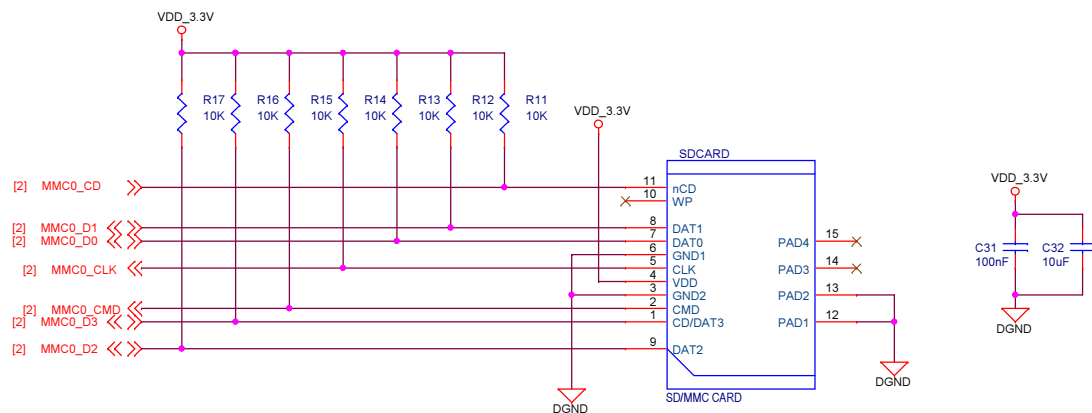

### DVP Camera

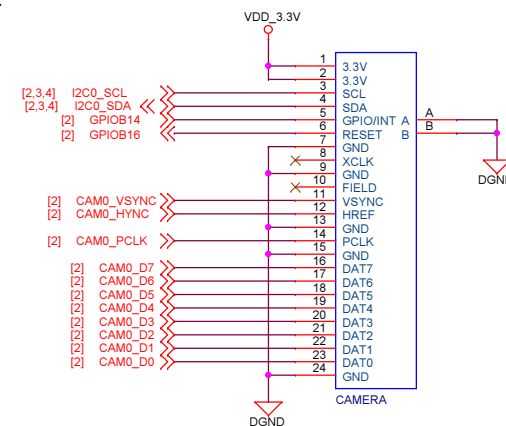

# USB 2.0 Host

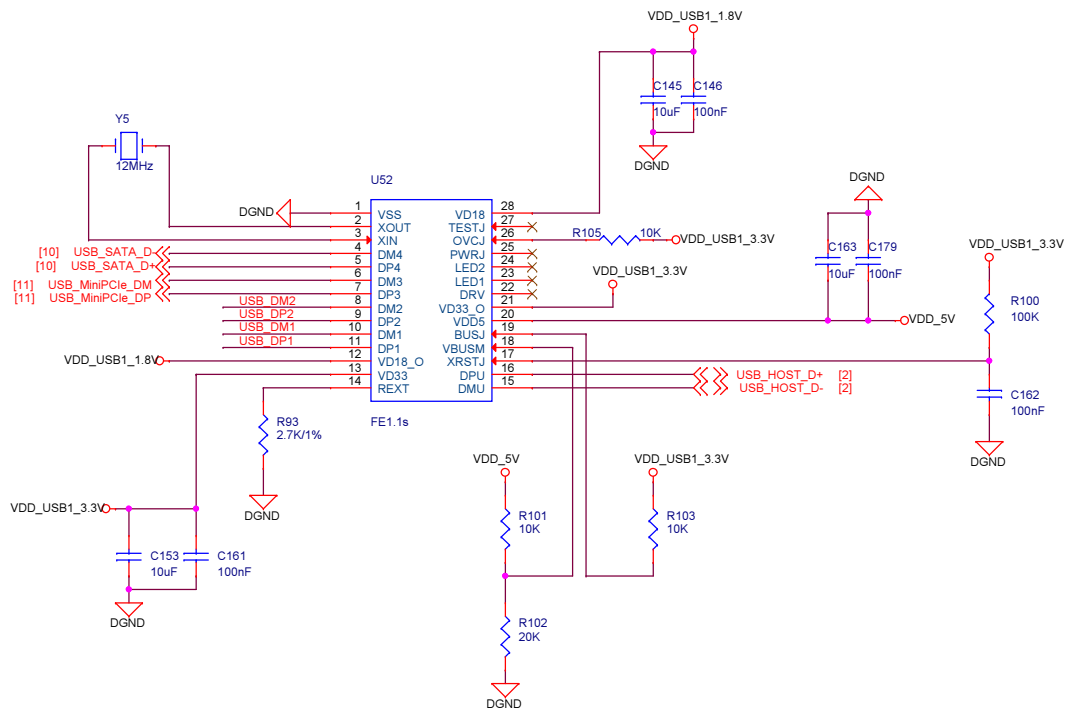

# USB 2.0 Slave

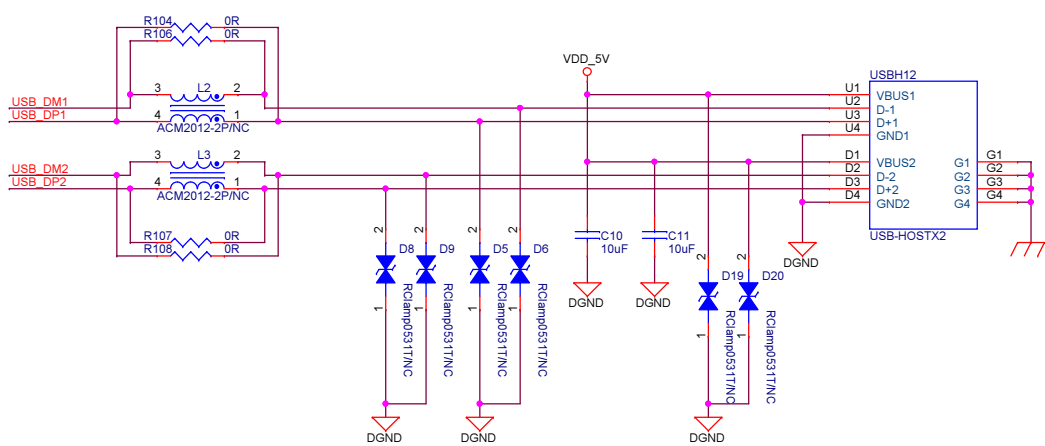
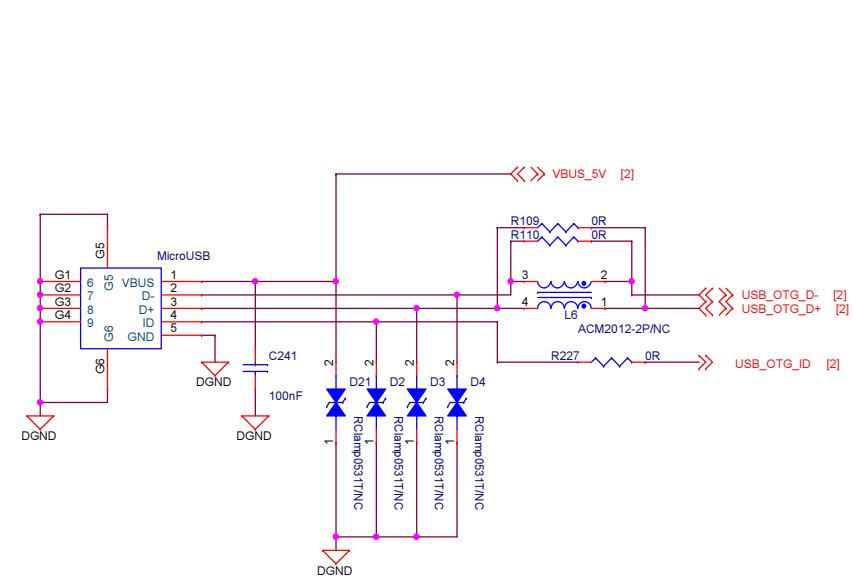

Smart4418		
Size A3	Document Number 07_USB Host, USB Device	Rev 1606
Date: Wednesday, July 20, 2016	Sheet 7	of 12

# Wi-Fi/Bluetooth

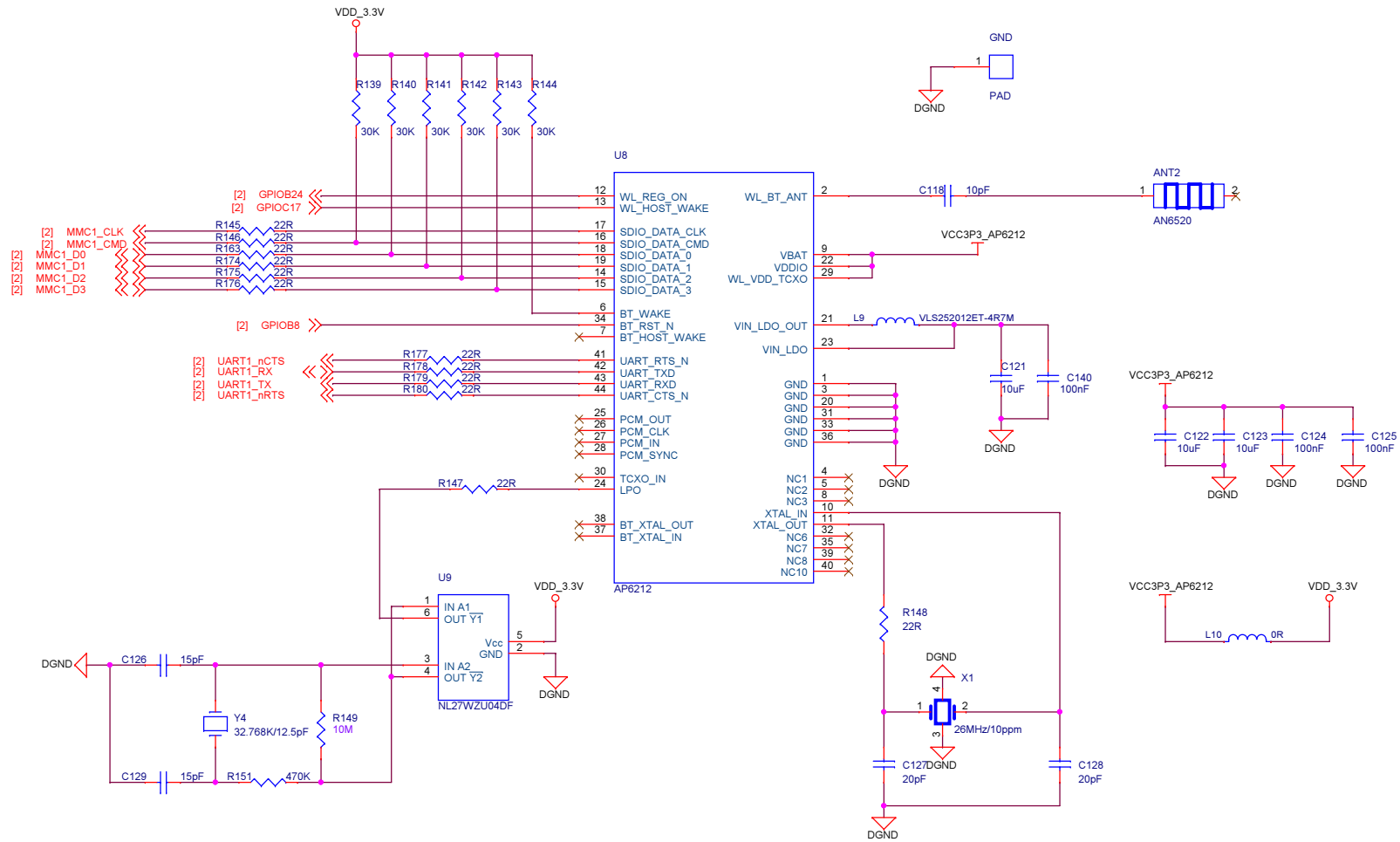

**FRIENDLYARM**

Smart4418		
Size A3	Document Number 08-Wi-Fi/BT	Rev 1606
Date: Wednesday, July 20, 2016	Sheet 8	of 12



Power

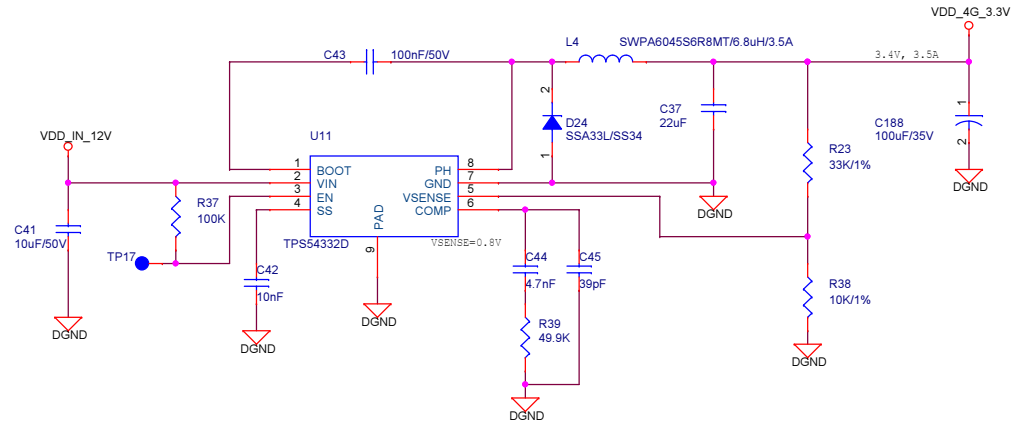
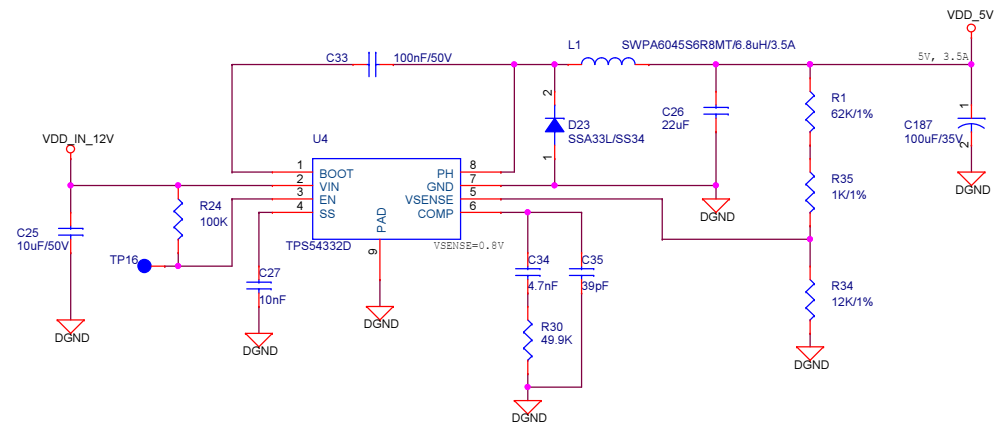
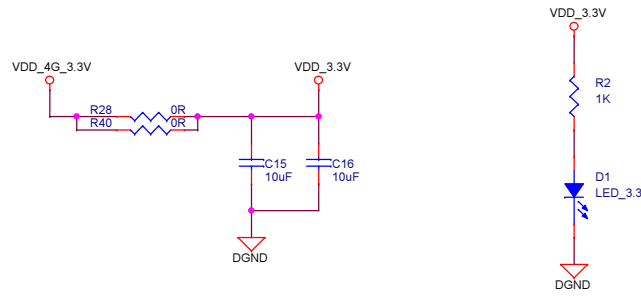
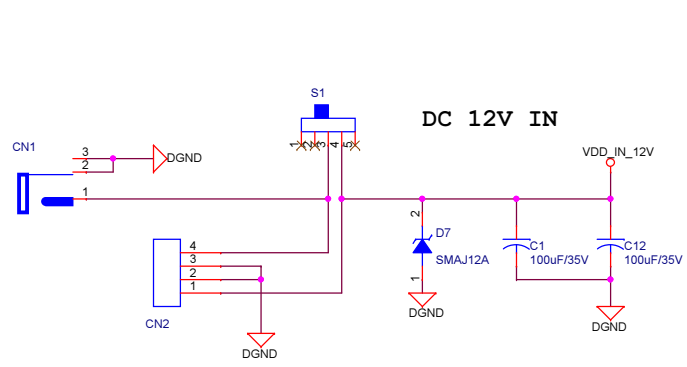

Smart4418		
Size A3	Document Number 09.Power	Rev 1606
Date: Wednesday, July 20, 2016	Sheet 9	of 12

# SATA

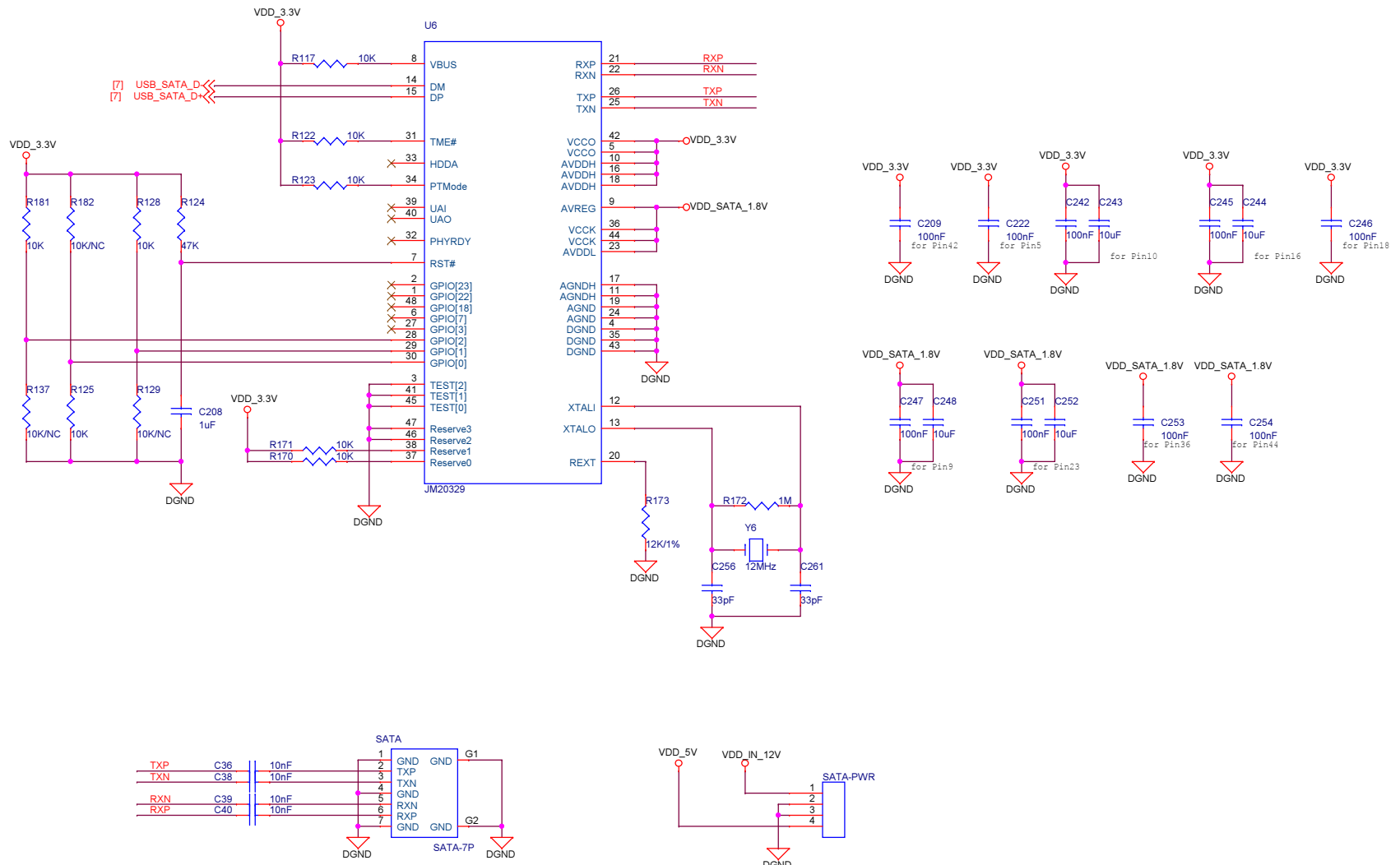

Smart4418		
Size A3	Document Number 10.USB-SATA	Rev 1606
Date: Wednesday, July 20, 2016	Sheet 10	of 12

# MiniPCIe for 4G Module

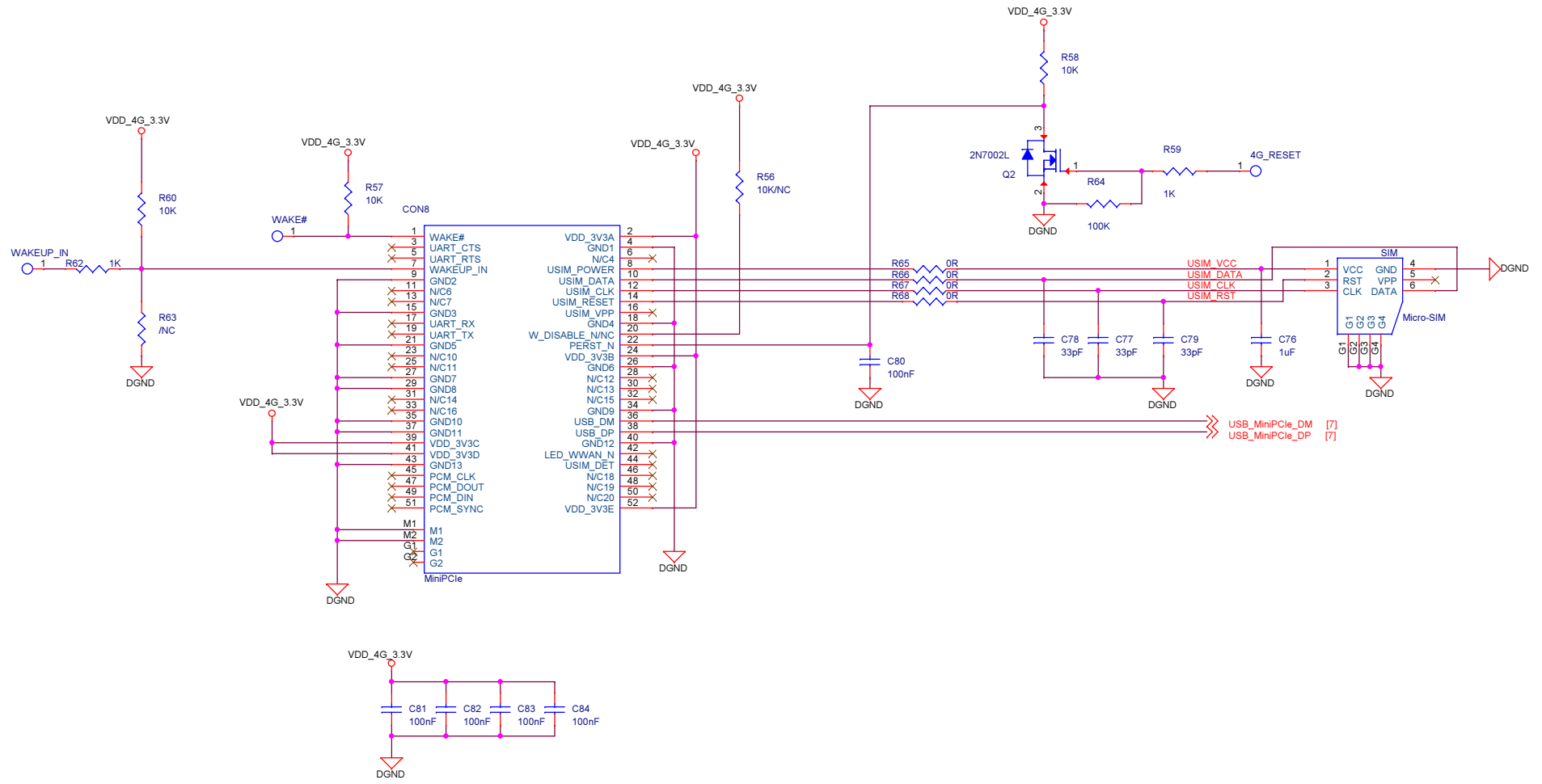

Smart4418		
Size A3	Document Number 11.MiniPCIe	Rev 1606
Date: Wednesday, July 20, 2016	Sheet 11	of 12

# Board Revision

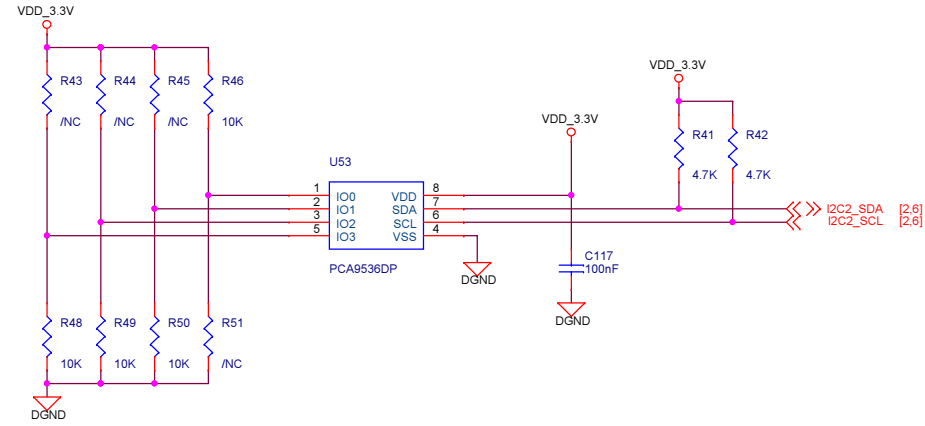

FRIENDLYARM

Smart4418		
Size A3	Document Number 12:I2C-Board-ID	Rev 1606
Date:	Wednesday, July 20, 2016	Sheet 12 of 12